

OKI electronic components

OD125

InGaAs PIN Photodiode for Optical Communications

GENERAL DESCRIPTION

The OD125 is designed as a receiver AMP for 30-Mbit digital signals. It features a PIN photodiode and AMP built into a TO-18 metal package.

FEATURES

- Light input: -27 through -15 dBm
- Frequency characteristics: 30 MHz (Min.)
- Trans impedance: 90 dB (Typ.)
- Peak-sensitivity wavelength : 1300 nm

APPLICATIONS

- For optical transmission module (for digital signal reception)

PIN CONFIGURATION (Unit: mm)

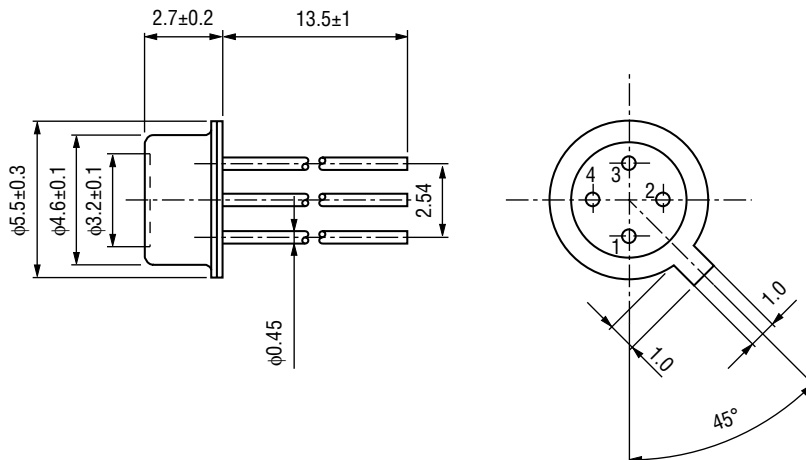

• Pin Connection Diagram

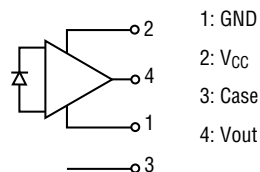

ABSOLUTE MAXIMUM RATINGS

Parameter	Symbol	Test Condition	Rating	Unit
Supply Voltage	V_{CC}	$T_a=25^\circ\text{C}$	8	V
Operating Temperature	T_{opr}	—	-30 to +80	$^\circ\text{C}$
Storage Temperature	T_{stg}	—	-40 to +100	$^\circ\text{C}$

ELECTRICAL AND OPTICAL CHARACTERISTICS

(Ambient Temperature $T_a=25^\circ\text{C}$)

Parameter	Symbol	Test Condition	Min.	Typ.	Max.	Unit
Output Bias Voltage	V_B	$V_{CC}=5\text{ V}$, Pin=0	1.45	1.65	1.85	V
Photosensitivity	R	$\lambda=1.3\ \mu\text{m}$, Pin=-20 dBm	25	—	—	kV/W
Cutoff Frequency	f_c	$V_{CC}=5\text{ V}$, -3 dB from peak value	35	—	—	MHz
Output Noise Level	—	$f=32\text{ MHz}$, Band width 3.1 kHz	—	—	-85	dBm
Supply Current	I_{CC}	$V_{CC}=5\text{ V}$, Pin=0	—	9	—	mA

TYPICAL CHARACTERISTICS

- Cutoff Frequency f_c vs. Ambient Temperature

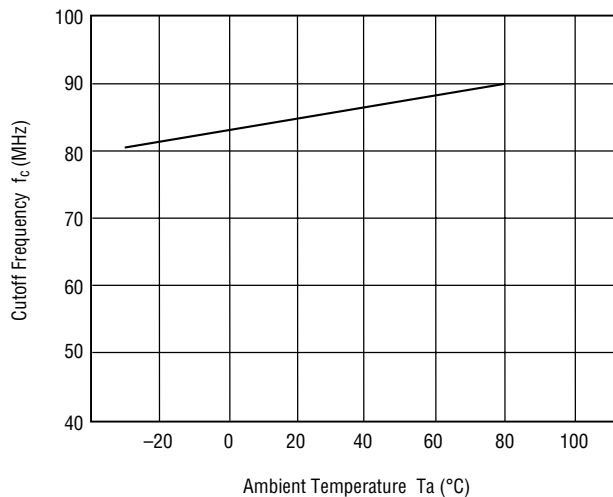

- **Output Voltage vs. Frequency (Ta=25°C)**

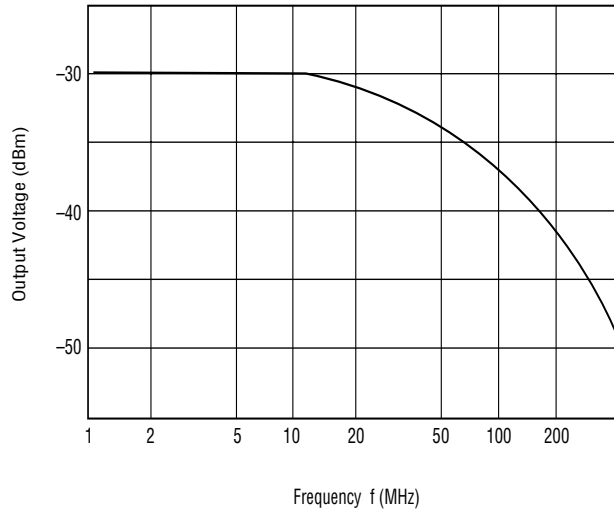

- **Dark Voltage vs. Ambient Temperature**

