

MSM65522/65P522**8-Bit Microcontroller with A/D Converter****GENERAL DESCRIPTION**

The MSM65522 is a high-performance 8-bit microcontroller that employs OKI original nX-8/50 CPU core. With a minimum instruction execution time of 400 ns (10MHz clock), the MSM65522 is capable of high-speed processing, and includes 8K bytes of program memory, 384 bytes of data memory (RAM), timers, serial ports and an A/D converter on chip. Also available is the MSM65P522, which replaces the on-chip program memory with one-time PROM.

FEATURES

- Operating range
 - Operating frequency : 1 to 10MHz ($V_{DD}=4.5$ to 5.5V)
1 to 5MHz ($V_{DD}=2.7$ to 5.5V)
 - Operating voltage : 2.7 to 5.5V
 - Operating temperature : -40 to +85°C
 - Memory space
 - Internal program memory : 8K bytes
 - Internal data memory : 384 bytes
 - Minimum instruction execution time : 400ns @ 10 MHz
 - Powerful instruction set : 81 basic instructions
8/16-bit operation instructions
Bit manipulation instructions
Compound function instructions
 - Abundant addressing modes
 - I/O ports
 - Input only port : 8-bit × 3
 - Timers : 4-bit × 1
 - : 8-bit × 1
 - : 8-bit auto-reload timer × 3
(One timer is shared by the baud rate generator. Combining the 8-bit timers, it is possible to use the timers as a 16-bit timer (1 channel).)
Watchdog timer × 1
 - Counters : Time base counter (14-bit) × 1
 - Serial ports : Shift register × 1
Serial port with baud rate generator (UART/Synchronous) × 1
 - A/D converter : 8 bits × 8 channels
 - External interrupts : 3
 - Interrupt sources : 11
 - Package Options
 - 42-pin plastic shrink DIP (SDIP42-P-600-1.78) : (Product name:MSM65522-xxxSS,
MSM65P522-xxxSS)
 - 42-pin plastic DIP (DIP42-P-600-2.54) : (Product name:MSM65522-xxxRS,
MSM65P522-xxxRS)
 - 44-pin plastic QFP (QFP44-P-910-0.80-2K) : (Product name:MSM65522-xxxGS-2K,
MSM65P522-xxxGS-2K)
 - 44-pin plastic QFJ (QFJ44-P-S650-1.27) : (Product name:MSM65522-xxxJS,
MSM65P522-xxxJS)
- xxx indicates the code number.

* Specifications are subject to change without notice.

BLOCK DIAGRAM

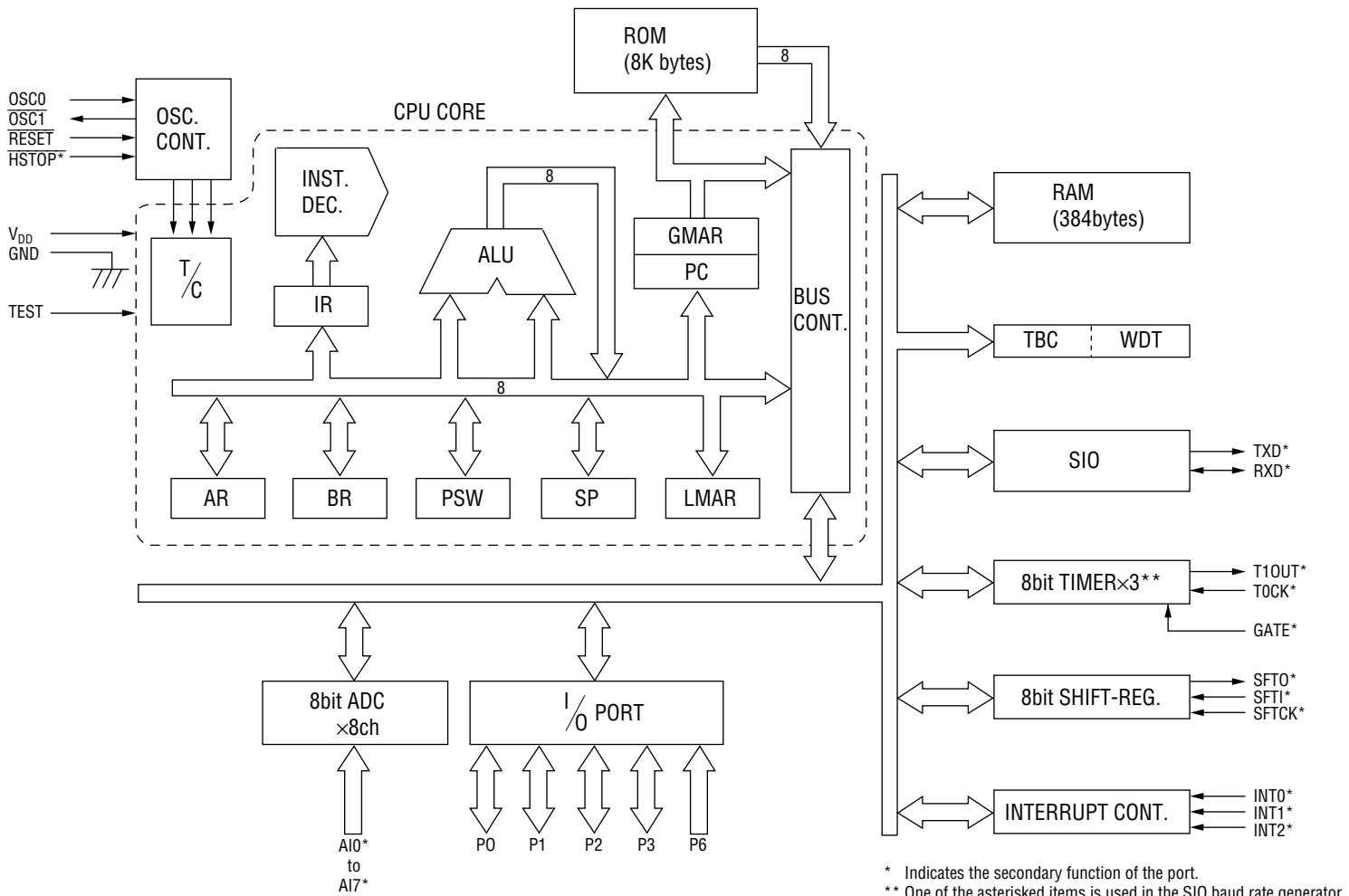

* Indicates the secondary function of the port.
 ** One of the asterisked items is used in the SIO baud rate generator.

PIN CONFIGURATION (TOP VIEW)

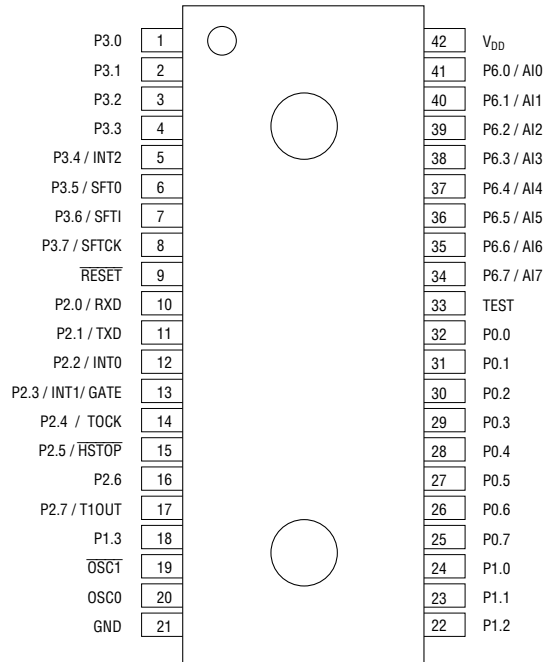

42-Pin Plastic Shrink DIP

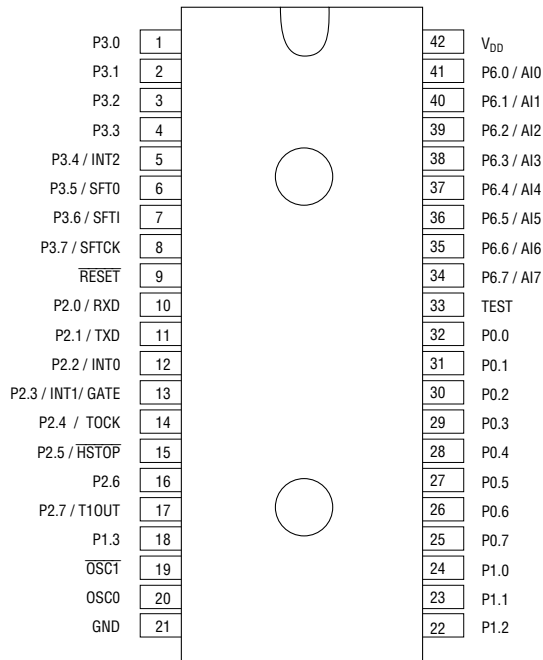

42-Pin Plastic DIP

PIN CONFIGURATION (TOP VIEW) (Continued)

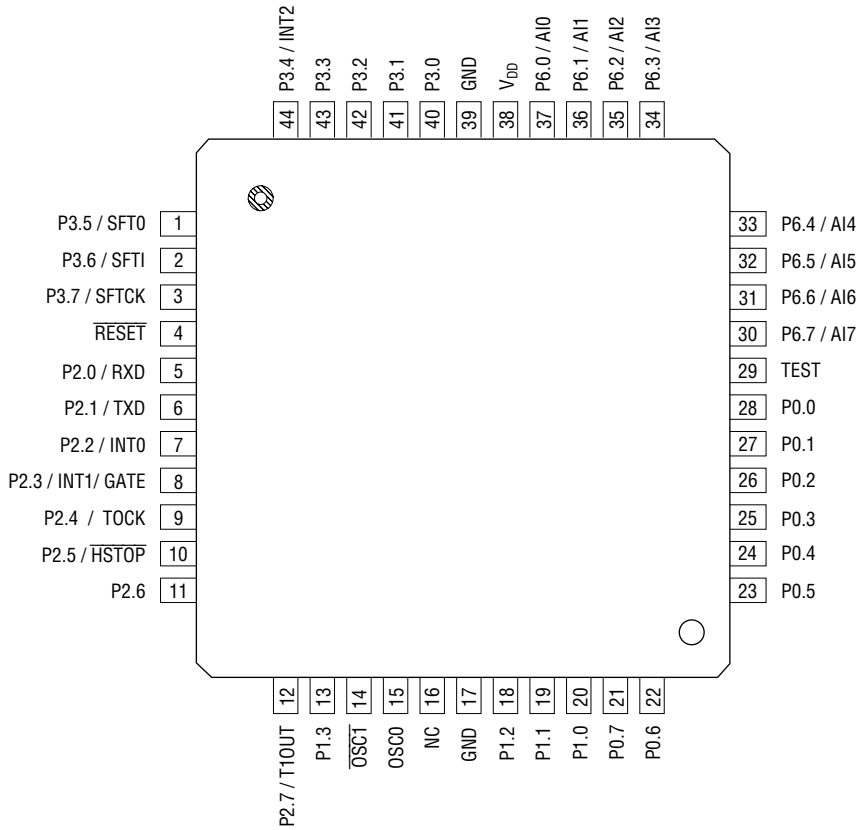

NC: No-connection pin

44-Pin Plastic QFP

PIN CONFIGURATION (TOP VIEW) (Continued)

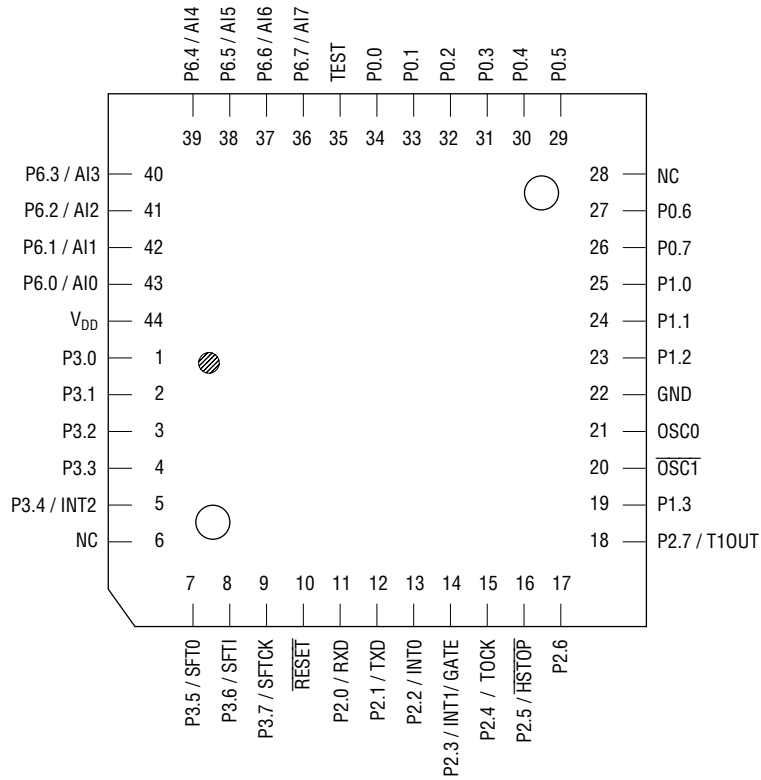

NC: No-connection pin

44-Pin Plastic QFJ

PIN DESCRIPTION

Basic Functions

| Function | Symbol | Type | Description |
|--------------|----------------------------|------|---|
| Power Supply | V _{DD} | — | +5V digital power supply (common to analog power supply) |
| | GND | — | 0V digital ground (common to analog ground) |
| Oscillation | OSC0 | I | Oscillator input pin: connects to a crystal oscillator (or ceramic resonator) or external clock. The master clock and external clock are used as the system clock without frequency division. |
| | $\overline{\text{OSC1}}$ | O | Oscillator input pin: connects to a crystal oscillator (or ceramic resonator). When an external clock is input to OSC0, leave $\overline{\text{OSC1}}$ open. |
| Control | $\overline{\text{RESET}}$ | I | System reset input: when this pin goes low, the internal state of the chip is initialized and program execution restarts from address 0040H. The input is pulled up to V _{DD} with an internal pull-up resistor. |
| | TEST | I | Test input pin: connects to ground pin. |
| Port | P0.0 to P0.7 | I/O | 8-bit input/output port (Port 0) |
| | P1.0 to P1.3 | I/O | 8-bit input/output port (Port 1) |
| | P2.0 to P2.7 | I/O | 8-bit input/output port (Port 2): input or output can be selected for each bit by the port 2 direction register (P2DIR). In addition to their input/output port functions, the pins of port 2 have secondary functions: see the next table. |
| | P3.0 to P3.7 | I/O | 8-bit input/output port (Port 3): input or output can be selected for each bit by the port 3 direction register (P3DIR). In addition to their input/output port functions, the pins of port 3 have secondary functions: see the next table. |
| | P6.0/AI0 to P6.7/AI7 | I | 8-bit input port (Port 6): Functions as analog input channel during A/D conversion. |

Secondary Functions

| Function | Symbol | Type | Description |
|--------------------|------------|------|---|
| Serial Port | RXD | I/O | P2.0 secondary functions. UART: Input pin for a synchronous communication receive data. Synchronous: Input/output pin for serial port transmit/receive data. |
| | TXD | O | P2.1 secondary functions. UART: Input pin for a synchronous communication receive data. Synchronous: Output pin for serial port synchronizing clock. |
| External interrupt | INT0 | I | Secondary function of P2.2 input pin for external interrupt 0. The interrupt can be triggered by the rising edge, falling edge, or both edges of rising or falling. |
| | INT1/Gate | I | Secondary function of P2.3 input pin for external interrupt 1. The interrupt can be triggered by the rising edge, falling edge, or both rising and falling edges. Also used as a gate signal input pin for gating the counter of timer 0. |
| | INT2 | I | Secondary function of P3.4 input pin for external interrupt 2. The interrupt can be triggered by the rising edge, falling edge, or both rising and falling edges. |
| Control | HSTOP | I | Secondary function of P2.0 input pin for hardware stop mode. If this pin goes low while the HSTP bit in SBYCON is set to 1, the chip enters hard stop mode. In hardware stop mode the clock stops and the CPU and on-chip peripheral functions shut down to conserve power. |
| Shift Registers | SFTO | O | P3.5 secondary functions. Shift register data output pin. |
| | SFTI | I | P3.6 secondary functions. Shift register data output pin. |
| | SFTCK | I/O | P3.7 secondary functions. Shift register synchronizing clock input/output pin. In master mode: clock output In slave mode: clock input |
| Timer 0 | T0CK | I | Secondary function of P2.4: external clock input pin for timer 0. |
| Timer 1 | T1OUT | O | Secondary function of P2.7: outputs a waveform with twice the cycle of the overflow interval of timer 1. |
| A/D Converter | AI0 to AI7 | O | Secondary function of P6.0 to P6.7: functions as analog input channel in A/D conversion. |

MEMORY MAPS

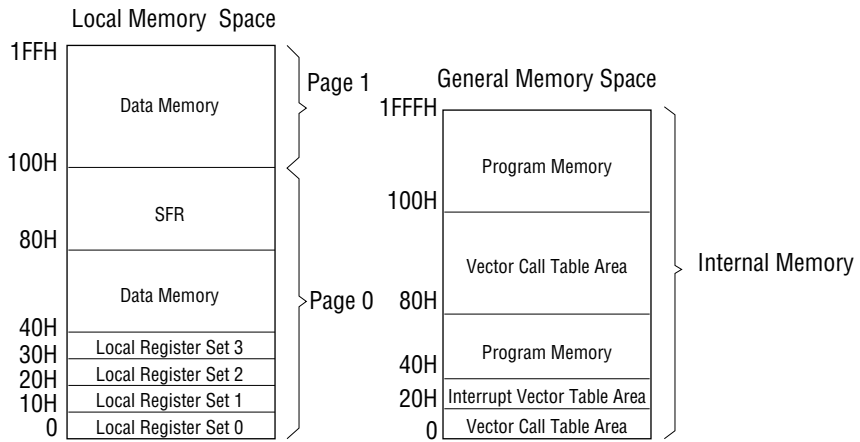

ABSOLUTE MAXIMUM RATINGS

| Parameter | Symbol | Condition | Rating | Unit |
|----------------------|-----------|---------------------------------------|----------------------|------------------|
| Supply Voltage | V_{DD} | $T_a=25^\circ\text{C}$ | -0.3 to +7.0 | V |
| Input Voltage | V_I | | -0.3 to $V_{DD}+0.3$ | |
| Output Voltage | V_O | | -0.3 to $V_{DD}+0.3$ | |
| Analog Input Voltage | V_{AI} | | -0.3 to $V_{DD}+0.3$ | |
| Power Dissipation | P_D | $T_a=25^\circ\text{C}$ per package | 400 | mW |
| | | $T_a=25^\circ\text{C}$ per one output | 50 | |
| Storage Temperature | T_{STG} | — | -55 to +150 | $^\circ\text{C}$ |

RECOMMENDED OPERATING CONDITIONS

| Parameter | Symbol | Condition | Range | Unit |
|------------------------------------|--------------|-----------------------|---------------|------------------|
| Supply Voltage | V_{DD} | $f_{osc} \leq 10$ MHz | 4.5 to 5.5 | V |
| | | $f_{osc} \leq 5$ MHz | 2.7 to 5.5 | |
| Analog Input Voltage | V_{AI} | — | 0 to V_{DD} | |
| Memory Hold Voltage | V_{DDMH} | $f_{osc}=0$ Hz | 2.0 to 5.5 | |
| Operating Frequency *1 | f_{osc} | $V_{DD}=4.5$ to 5.5 | 1 to 10 | MHz |
| | | $V_{DD}=2.7$ to 4.5 | 1 to 5 | |
| External Clock Operating Frequency | f_{EXTCLK} | $V_{DD}=4.5$ to 5.5 | 0 to 10 | MHz |
| | | $V_{DD}=2.7$ to 4.5 | 0 to 5 | |
| Operating Temperature | T_{OP} | — | -40 to +85 | $^\circ\text{C}$ |

*1 This is due to the standard of a crystal oscillator or resonator.

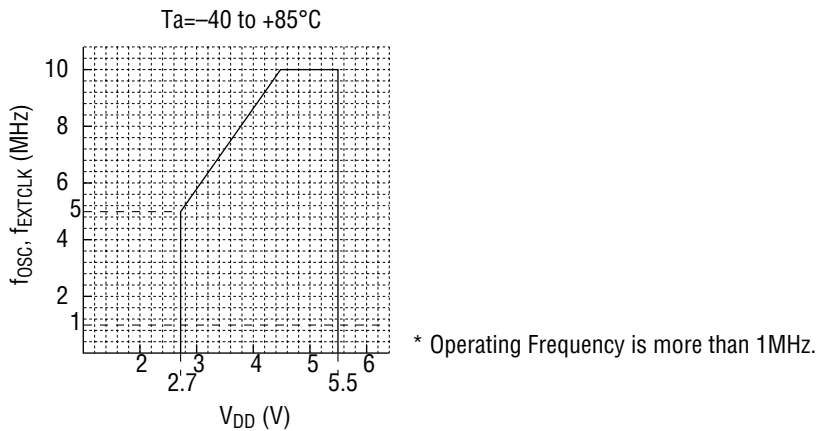

Figure 1. Supply Voltage vs. Operating frequency

ELECTRICAL CHARACTERISTICS

DC Characteristics 1 (V_{DD}=4.5 to 5.5V, 5V Version)

(GND=0V, T_a=-40 to +85°C)

| Parameter | Symbol | Condition | Min. | Typ. | Max. | Unit |
|---------------------------------------|---------------------|--------------------------------------|-------------------------|------|-------------------------|------|
| Schmitt Trigger Circuit Input Voltage | V _{T-} | — | 0.3V _{DD} | — | — | V |
| | V _{T+} | | — | — | 0.7V _{DD} | |
| | ΔV _T | | — | 1.0 | — | |
| "H" Input Voltage 1 | *2 V _{IH1} | — | 0.3V _{DD} +0.7 | — | V _{DD} +0.3 | V |
| "H" Input Voltage 2 | *3 V _{IH2} | — | 0.7V _{DD} | — | V _{DD} +0.3 | |
| "L" Input Voltage | *4 V _{IL} | — | -0.3 | — | 0.3V _{DD} -0.3 | |
| "H" Output Voltage 2 | V _{OH} | I _{OH} =-400μA | V _{DD} -0.4V | — | — | |
| "L" Output Voltage 1 | V _{OL} | I _{OL} =1.6mA | — | — | 0.4 | μA |
| Input Leakage Current 1 | *5 I _{LI1} | V _I =V _{DD} /0V | — | — | ±1 | |
| Input Leakage Current 2 | *6 I _{LI2} | V _I =V _{DD} /0V | — | — | ±10 | |
| Pull-up Resistor | *7 R _{RST} | V _I =0V | 30 | 50 | 80 | KΩ |
| Input Capacitance | C _I | f=1MHz, T _a =25°C | — | 5 | — | pF |
| Current Consumption | *8 I _{DDS} | 5V, Stop mode | — | 2 | 50 | μA |
| Current Consumption | I _{DD} | f _{OSC} =10MHz, 5V, no load | — | 25 | 35 | mA |

*1 P0 to P3 (Includes secondary function inputs)

*2 P6

*3 OSC0 and $\overline{\text{RESET}}$

*4 P6, OSC0, $\overline{\text{RESET}}$

*5 P6

*6 Excludes P6. $\overline{\text{RESET}}$ sets to V_{DD} and TEST sets to 0V

*7 $\overline{\text{RESET}}$

*8 The ports set for input mode are V_{DD} or 0V, the ports except these are no load and A/D converter is not active.

DC Characteristics 2 (2.7 to 4.5V, 3V Version)

(GND=0V, Ta=-40 to +85°C)

| Parameter | Symbol | Condition | Min. | Typ. | Max. | Unit |
|---------------------------------------|---------------------|-------------------------------------|-------------------------|------|-------------------------|------|
| Schmitt Trigger Circuit Input Voltage | V_{T-} | — | 0.3V _{DD} | — | — | V |
| | V_{T+} | | — | — | 0.7V _{DD} | |
| | ΔV_T | | — | 0.5 | — | |
| "H" Input Voltage | *2 V_{IH1} | — | 0.3V _{DD} +0.7 | — | V _{DD} +0.3 | V |
| "H" Input Voltage | *3 V_{IH2} | — | 0.7V _{DD} +0.3 | — | V _{DD} +0.3 | |
| "L" Input Voltage | *4 V_{IL} | — | -0.3 | — | 0.3V _{DD} -0.3 | |
| "H" Output Voltage | V_{OH} | I _{OH} =-20μA | V _{DD} -0.1 | — | — | |
| "L" Output Voltage | V_{OL} | I _{OL} =20μA | — | — | 0.1 | μA |
| Input Leakage Current 1 | *5 I _{LI1} | V _I =V _{DD} /0V | — | — | ±1 | |
| Input Leakage Current 1 | *6 I _{LI1} | V _I =V _{DD} /0V | — | — | ±1 | KΩ |
| Pull-up Resistor | *7 R _{RST} | V _I =0V | 30 | 50 | 80 | |
| Input Capacitance | C _I | f=1MHz, Ta=25°C | — | 5 | — | pF |
| Current Consumption | *8 I _{DDS} | 3V, stop mode | 1 | — | 25 | μA |
| Current Consumption | I _{DD} | 5MHz, 3V, no load | 10 | 6 | 15 | mA |

- *1 P0 to P3 (Includes secondary function inputs)
- *2 P6
- *3 OSC0 and $\overline{\text{RESET}}$
- *4 P6, OSC0, $\overline{\text{RESET}}$
- *5 P6
- *6 Excludes P6. $\overline{\text{RESET}}$ sets to V_{DD} and TEST sets to 0V.
- *7 $\overline{\text{RESET}}$
- *8 The ports except these are no load, and A/D converter active.

AC Characteristics

CPU control (OSC0 Clock)

(V_{DD}=2.7 to 5.5 V, GND=0V, Ta=-40 to +85°C)

| Parameter | Symbol | Condition | Min. | Max. | Unit |
|-----------------------|------------------|-------------------------------|------|------|------|
| Clock Period | t _c | V _{DD} =4.5 to 5.5 V | 100 | — | ns |
| "L" Clock Pulse Width | t _{CLW} | | 45 | — | |
| "H" Clock Pulse Width | t _{CHW} | | 45 | — | |
| Clock Period | t _c | V _{DD} =2.7 to 4.5 V | 200 | — | |
| "L" Clock Pulse Width | t _{CLW} | | 90 | — | |
| "H" Clock Pulse Width | t _{CHW} | | 90 | — | |

CPU control (OSC0 Clock)

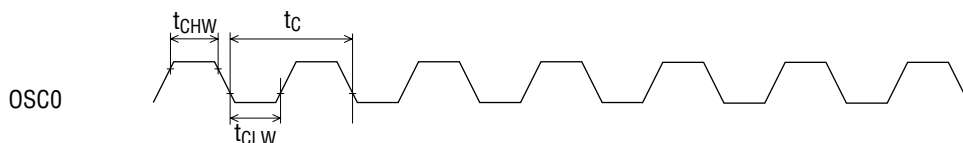

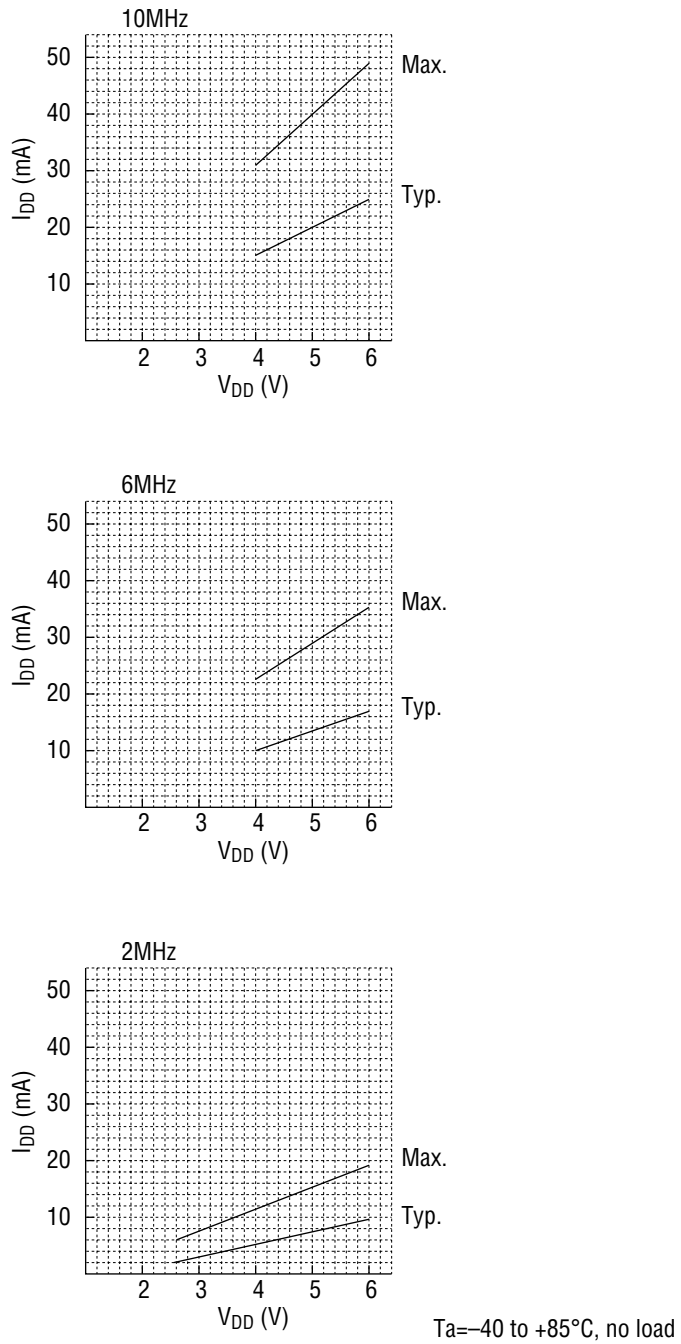

Figure 2. Voltage vs. Current

• CPU control

($V_{DD}=2.7$ to $5.5V$, $GND=0V$, $T_a=-40$ to $+85^{\circ}C$)

| Parameter | Symbol | Condition | Min. | Max. | Unit |
|----------------------|-------------|-----------|------|------|------|
| RESET Pulse Width *1 | t_{RESW1} | — | 20 | — | ns |
| RESET Pulse Width *2 | t_{RESW2} | — | *3 | — | — |

*1 Excluding power ON, stop mode and hard stop mode.

*2 In power ON, stop mode and hard stop mode.

*3 Oscillation stabilization time depends on resonator.

RESET Pulse Width

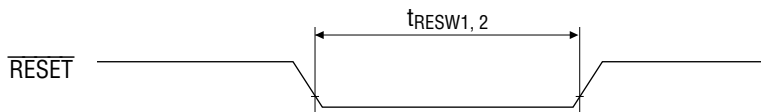

• Peripheral control 1

($V_{DD}=2.7$ to $5.5V$, $GND=0V$, $T_a=-40$ to $+85^{\circ}C$)

| Parameter | Symbol | Condition | Min. | Max. | Unit |
|-----------|--------------------------------|------------------------|--------------------|------|------|
| OSC | Clock Period | $V_{DD}=4.5$ to $5.5V$ | 100 | — | ns |
| | | $V_{DD}=2.7$ to $4.5V$ | 200 | — | |
| EXI | External Interrupt Pulse Width | — | $4 t_c$ | — | |
| T0 | External Clock Pulse Width | | $4 t_c$ | — | |
| | GATE Pulse Width | | $1 t_{TOCLK}^{*1}$ | — | |

*1 t_{TOCLK} : Timer 0 count clock period selected by T0CON.

1) OSC0

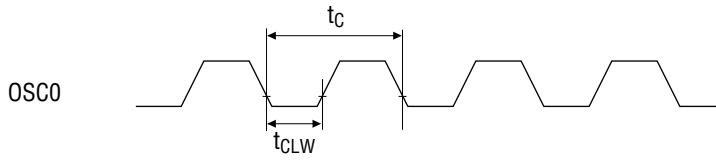

2) EXI Pulse Width

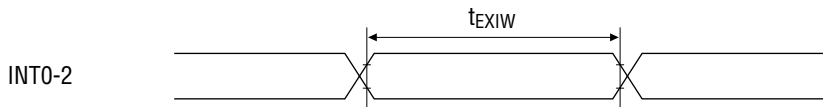

3) T0

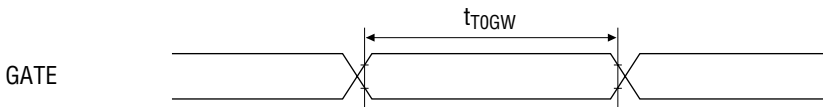
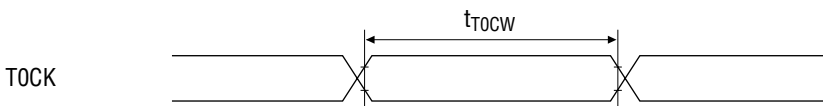

• Peripheral control 2

($V_{DD}=AV_{DD}=2.7$ to $5.5V$, $GND=0V$, $T_a=-40$ to $+85^{\circ}C$)

| Parameter | | Symbol | Condition | Min. | Max. | Unit |
|---------------------------------|-----------------------------------|-------------|------------------------|-------------------|------|------|
| OSC | Clock Period | t_C | $V_{DD}=4.5$ to $5.5V$ | 100 | — | ns |
| | | | $V_{DD}=2.7$ to $4.5V$ | 200 | — | |
| SFT | SFTCK Period | t_{SFC} | $C_L=100pF$ | $8 t_C$ | — | |
| | SFTCK "L" Pulse Width | t_{SFCLW} | | $4 t_C-20$ | — | |
| | SFTCK "H" Pulse Width | t_{SFCHW} | | $4 t_C-20$ | — | |
| | SFTO Setup Time | t_{SFOS} | | $t_{SFCLW}-100$ | — | |
| | SFTO Hold Time | t_{SFOH} | | $t_{SFCHW}-100$ | — | |
| | SFTI Setup Time | t_{SFIS} | | 100 | — | |
| | SFTI Hold Time | t_{SFIH} | | 100 | — | |
| SIO (Clock Synchronous Mode) | Synchronous Clock Period | t_{SIC} | $C_L=100pF$ | $8 t_C$ | — | |
| | Synchronous Clock "L" Pulse Width | t_{SICLW} | | $4 t_C-20$ | — | |
| | Synchronous Clock "H" Pulse Width | t_{SICHW} | | $4 t_C-20$ | — | |
| | Output Data Setup Time | t_{SIOS} | | $6 t_C-100$ | — | |
| | Output Data Hold Time | t_{SIOH} | | $2 t_C-100$ | — | |
| | Input Data Setup Time | t_{SIIS} | | $t_C+t_{CLW}+100$ | — | |
| | Input Data Hold Time | t_{SIIH} | | 0 | — | |

1) SFT

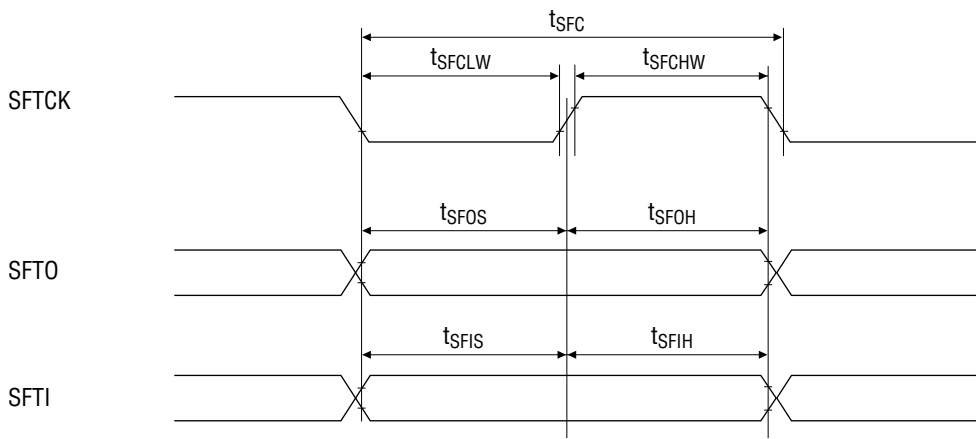

2) SIO
(Clock Synchronous Mode)

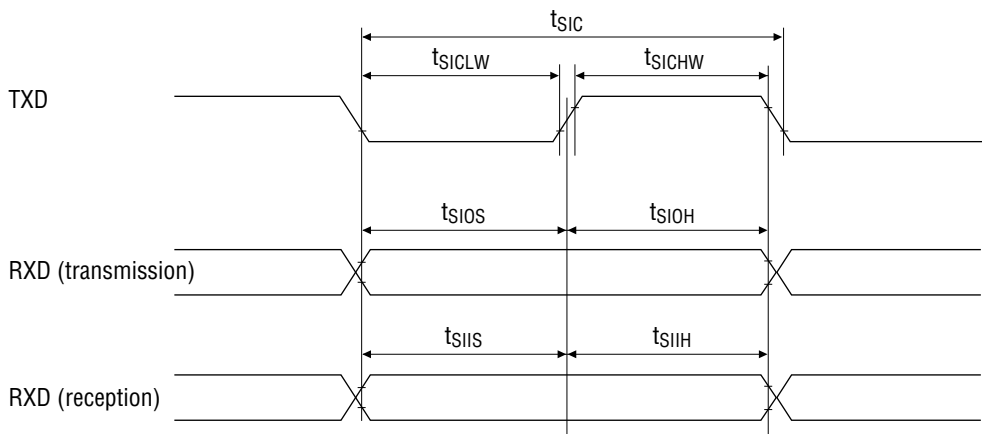

A/D Converter Characteristics

(V_{DD}=4.5 to 5.5V/2.7 to 4.5V, GND=0V, T_a=-40 to +85°C)

| Parameter | Symbol | Condition | Min. | Typ. | Max. | Unit |
|------------------------------|-------------------|---|------|-------|--------------------|-------|
| Resolution | n | See the recommended circuit (Fig. 3). Analog input source impedance R _I ≤5kΩ | — | 8 | — | bit |
| Absolute Error | E _L | | — | — | +1.5/+2 -1.5/-2 | LSB |
| Differential Linearity Error | E _D | | — | — | ±0.5/±1 | LSB |
| Zero Point Error | E _{ZS} | | — | — | +1.5/+2 | LSB |
| Full Scale Error | E _{FS} | | — | — | -1.5/-2 | LSB |
| Crosstalk | E _{CT} | See the measuring circuit (Fig. 4). | — | — | ±0.5/±1 | LSB |
| Conversion time * | t _{CONV} | f _{OSC} =10 MHz / 5 MHz | — | 16/32 | — | μs/CH |

* 14.8/2.96μs/CH for the one time conversion follows setting the GO bit.

Definitions of Terms

- (1) Resolution
The minimum distinguishable analog value. For 8 bits, 2⁸=256, i.e. (V_{RH}-V_{RL}) ÷ 256.
- (2) Linearity Error
The variance between the ideal conversion characteristics as an 8-bit A/D converter and actual conversion characteristics (does not include quantized error).

The ideal conversion characteristics refer to steps of the voltage between V_{RH} and V_{RL} into 256 intervals.
- (3) Differential Linearity Error
Indicates the smoothness of the conversion. The width of analog input voltage corresponding to the change by one bit of digital output is 1 LSB = (V_{RH}-V_{RL}) ÷ 256 ideally. The variance between this ideal bit size and bit size at arbitrary point in the conversion range.
- (4) Zero Scale Error
The variance between the ideal conversion characteristics at the switching point of digital outputs "000H to 001H" and actual conversion characteristics.
- (5) Full Scale Error
The variance between the ideal conversion characteristics at the switching point of digital outputs "0FEH to 0FFH" and actual conversion characteristics.

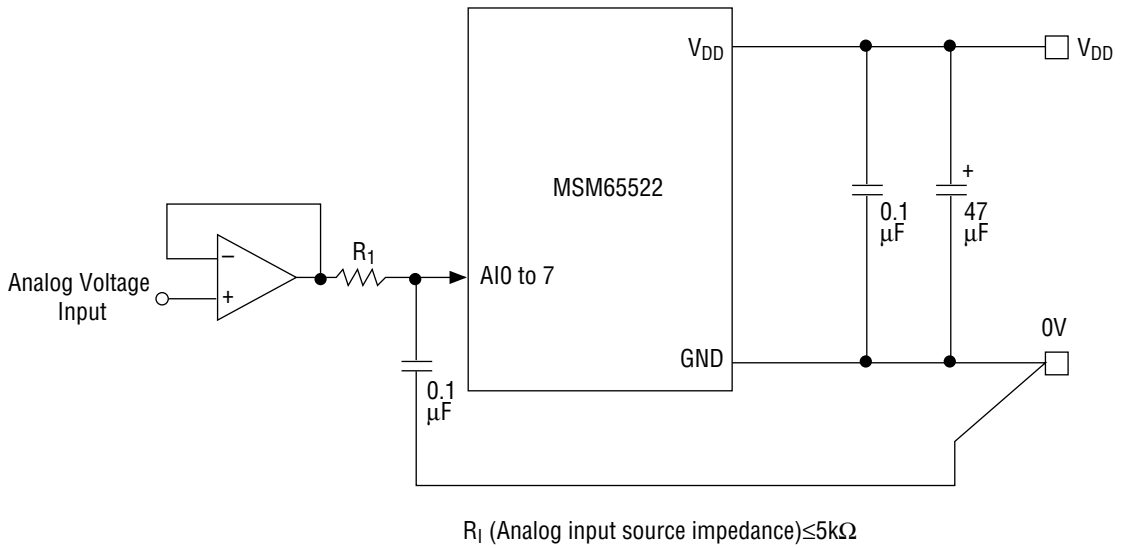

Figure 3. Recommended Circuit

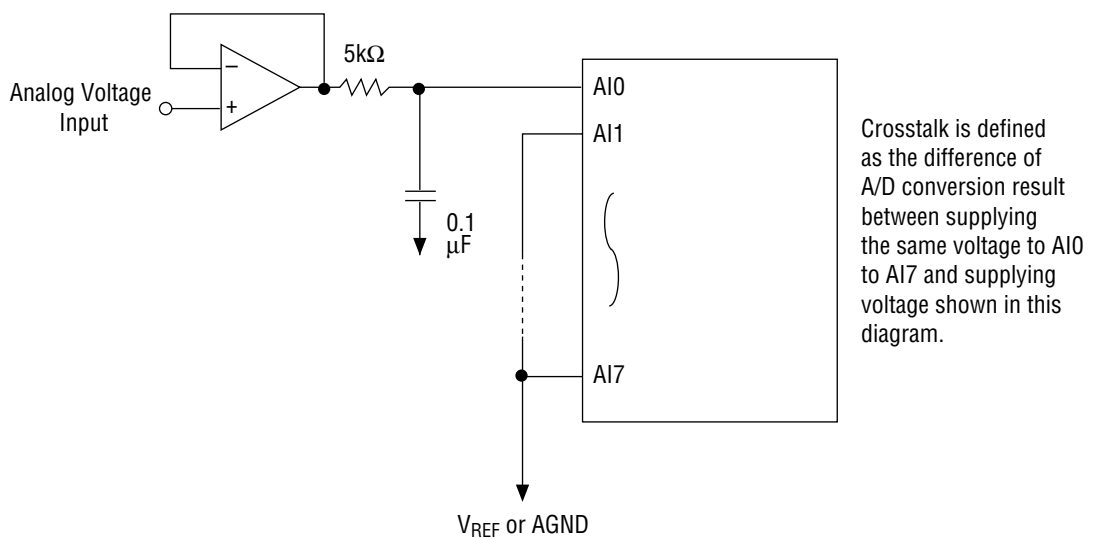
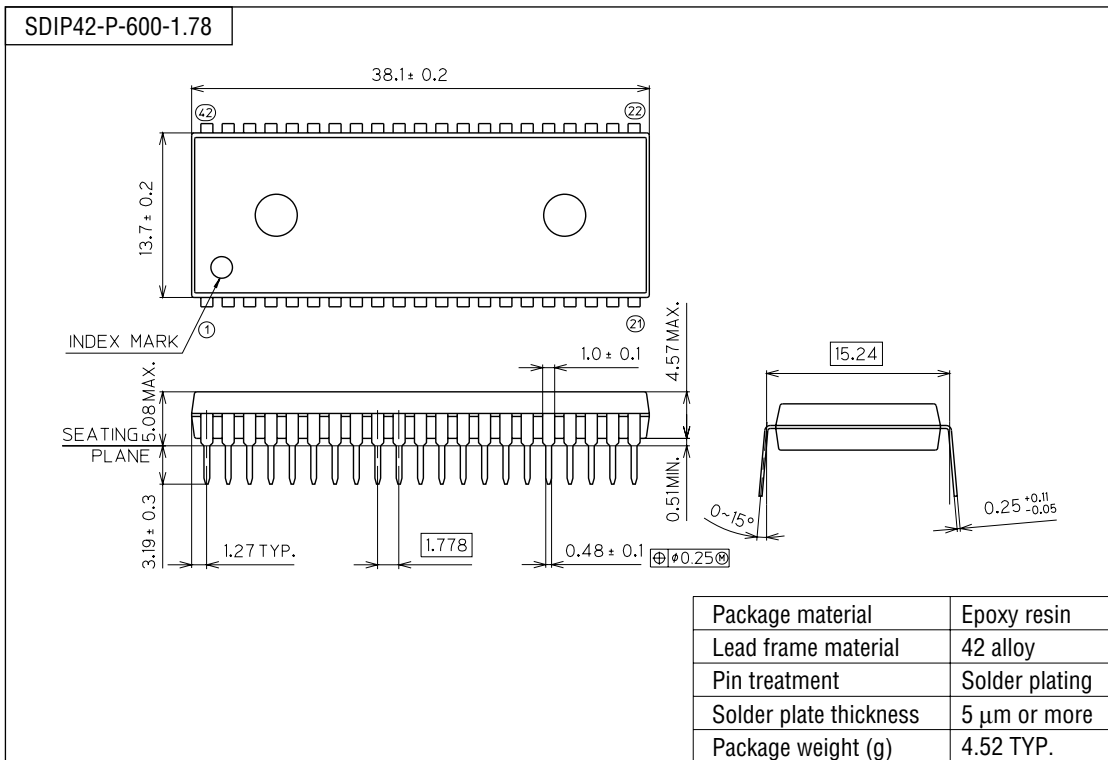

Figure 4. Crosstalk Measuring Circuit

PACKAGE DIMENSIONS

(Unit : mm)



Notes for Mounting the Surface Mount Type Package

The SOP, QFP, TSOP, SOJ, QFJ (PLCC), SHP and BGA are surface mount type packages, which are very susceptible to heat in reflow mounting and humidity absorbed in storage. Therefore, before you perform reflow mounting, contact Oki's responsible sales person for the product name, package name, pin number, package code and desired mounting conditions (reflow method, temperature and times).

(Unit : mm)

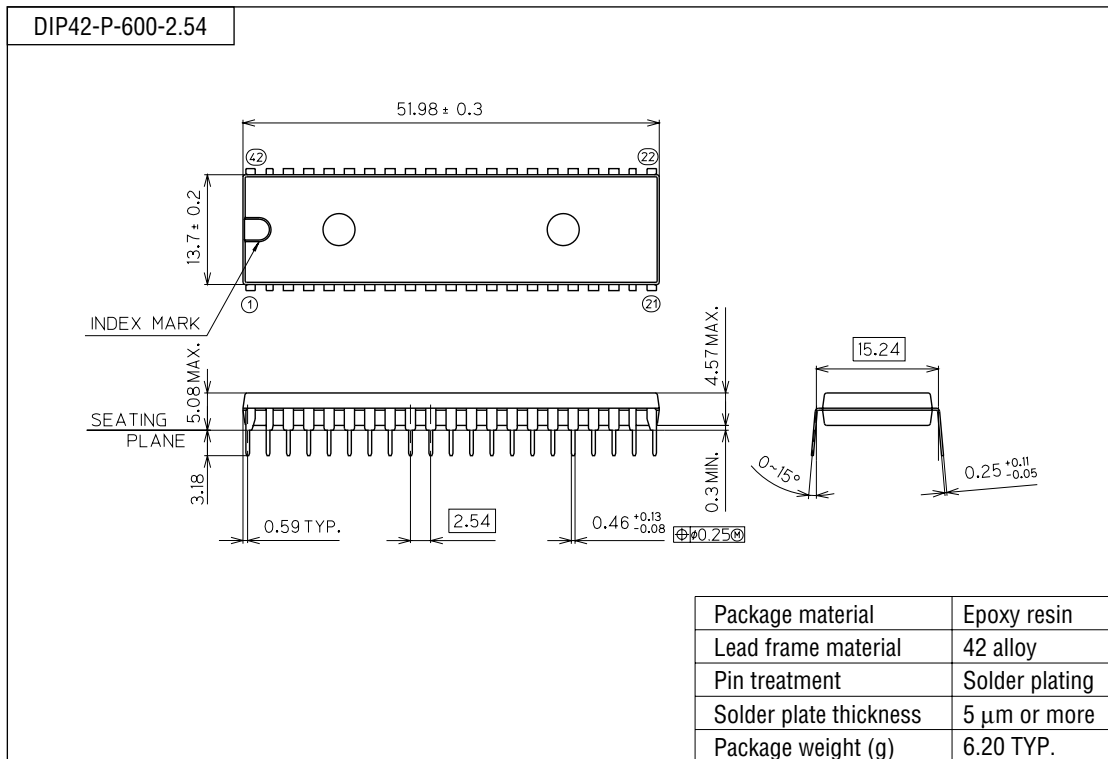

Notes for Mounting the Surface Mount Type Package

The SOP, QFP, TSOP, SOJ, QFJ (PLCC), SHP and BGA are surface mount type packages, which are very susceptible to heat in reflow mounting and humidity absorbed in storage. Therefore, before you perform reflow mounting, contact Oki's responsible sales person for the product name, package name, pin number, package code and desired mounting conditions (reflow method, temperature and times).

(Unit : mm)

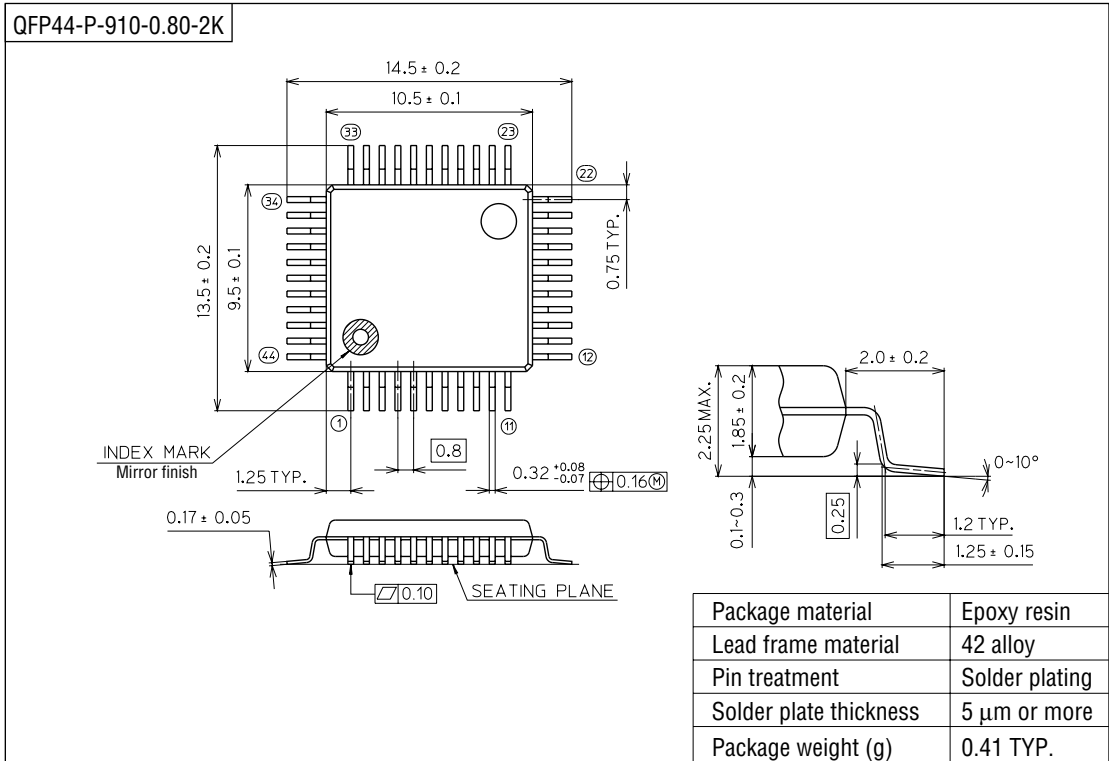

Notes for Mounting the Surface Mount Type Package

The SOP, QFP, TSOP, SOJ, QFJ (PLCC), SHP and BGA are surface mount type packages, which are very susceptible to heat in reflow mounting and humidity absorbed in storage. Therefore, before you perform reflow mounting, contact Oki's responsible sales person for the product name, package name, pin number, package code and desired mounting conditions (reflow method, temperature and times).

(Unit : mm)

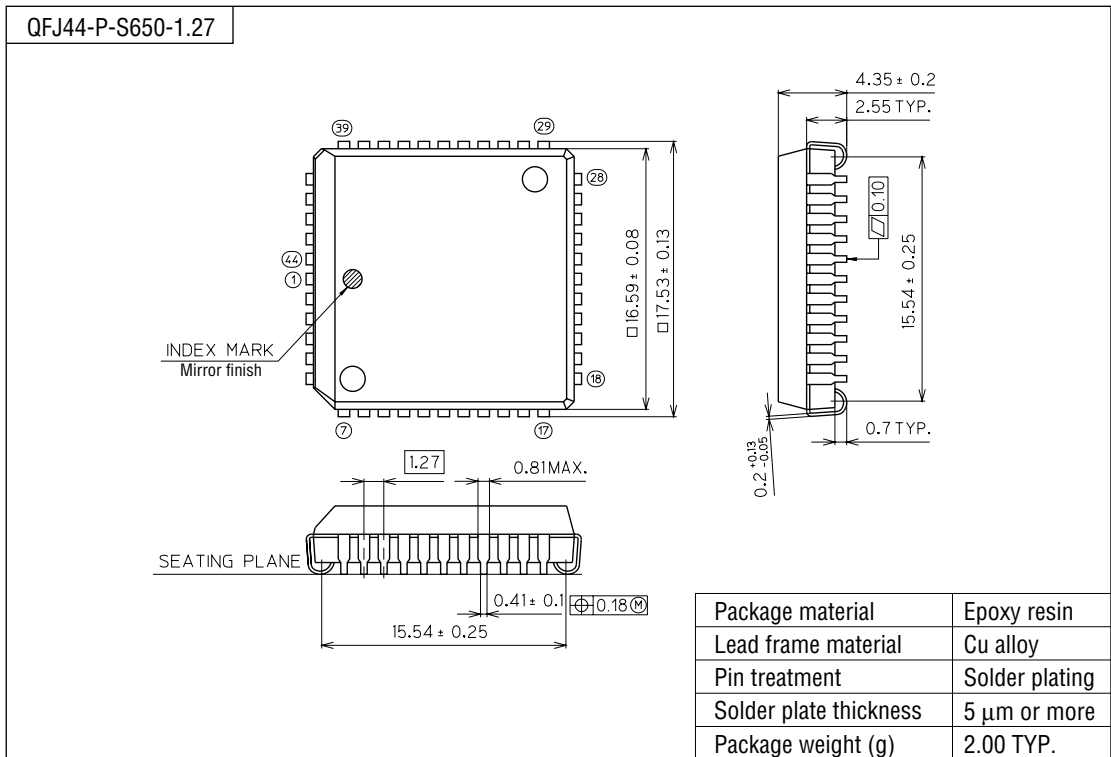

Notes for Mounting the Surface Mount Type Package

The SOP, QFP, TSOP, SOJ, QFJ (PLCC), SHP and BGA are surface mount type packages, which are very susceptible to heat in reflow mounting and humidity absorbed in storage. Therefore, before you perform reflow mounting, contact Oki's responsible sales person for the product name, package name, pin number, package code and desired mounting conditions (reflow method, temperature and times).