

TWO ELECTRODE SURGE ARRESTERS

CG/CG2 Series



DESCRIPTION

ClareREMtech's two electrode CG/CG2 Comgaps are designed for a high degree of surge protection at a low cost. The CG Series (75-110V) is primarily used for protection of test and communication equipment in which low voltage limits and extremely low arc voltages are required. The CG2 Series (145V-1000V) is used for the protection of test and communication equipment for which higher voltage limits and holdover voltages are necessary. Comgaps function as switches which dissipate a minimum amount of energy and therefore handle currents that far surpass other types of transient voltage protection.

FEATURES

- Small size
- Rugged ceramic-metal construction
- Low capacitance (<1pF)
- Non Radioactive 600-1000 V
- Available with or without leads
- Available in tape-and-reel packaging

APPLICATIONS

- Communication lines
- CATV equipment
- Test equipment
- Data lines
- Power supplies
- Instrumentation circuits
- Medical electronics

APPROVALS

- UL Recognized: File Number E111526
- Meets REA PE-80

RATINGS (@ 25° C)

Parameter	Min	Typ	Max	Units
DC Breakdown Voltage	60	75	90	V
	72	90	108	V
	88	110	132	V
	116	145	174	V
	195	230	265	V
	213	250	288	V
	255	300	345	V
	297	350	403	V
	400	470	540	V
	510	600	690	V
Insulation Resistance	680	800	920	V
	850	1000	1150	V
Insulation Resistance	10 ¹⁰	-	-	Ω
Capacitance	-	-	1	pF
Operational Temperature	-40	-	+125	°C

(See detailed specifications for more information.)

USA 1-877-4REMTECH Europe 32-11-300868 Japan 81-3-3667-3302 Ext. 2419
 HongKong/China/Korea 852-2880-6773 Taiwan 886-2-2726-2177 Singapore/Far East 65-296-3388

TWO ELECTRODE SURGE ARRESTERS

SPECIFICATIONS

CG/CG2 Series

All characteristics at 25°C

PARAMETER	CONDITIONS	SYMBOL	CG75			CG90			CG110			UNITS
			MIN	TYP	MAX	MIN	TYP	MAX	MIN	TYP	MAX	
Device Specifications												
DC Breakdown	500V/s	V _{BD}	60	75	90	72	90	108	88	110	132	V
Impulse Breakdown	100V/μs	V _{bd}	- ¹⁰	-	400	- ¹⁰	-	400	- ¹⁰	-	450	V
Insulation Resistance	50V	IR	10	-	-	10	-	-	10	-	-	Ω
Capacitance	1MHz	C	-	-	1	-	-	1	-	-	1	pF
Arc Voltage	I=5A min	V _{ARC}	-	10	-	-	10	-	-	10	-	V
Life Ratings⁽¹⁾												
Surge Life	500A (10/1000μs)	-	1000	-	-	1000	-	-	1000	-	-	shots
Max Current Surge	20kA (8/20μs)	-	5	-	-	5	-	-	5	-	-	shots
AC Current	10x 1sec @ 60Hz	-	-	-	20	-	-	20	-	-	20	A
DC Holdover Voltage	per REA PE-80, 0.2A	-	-	55	-	-	65	-	-	80	-	V

PARAMETER	CONDITIONS	SYMBOL	CG2-145			CG2-230			CG2-250			UNITS
			MIN	TYP	MAX	MIN	TYP	MAX	MIN	TYP	MAX	
Device Specifications												
DC Breakdown	500V/s	V _{BD}	116	145	174	195	230	265	213	250	288	V
Impulse Breakdown	100V/μs	V _{bd}	- ¹⁰	-	500	- ¹⁰	-	600	- ¹⁰	-	625	V
Insulation Resistance	100V	IR	10	-	-	10	-	-	10	-	-	Ω
Capacitance	1MHz	C	-	-	1	-	-	1	-	-	1	pF
Arc Voltage	I=5A min	V _{ARC}	-	15	-	-	15	-	-	15	-	V
Life Ratings⁽¹⁾												
Surge Life	500A (10/1000μs)	-	1000	-	-	1000	-	-	1000	-	-	shots
Max Current Surge	20kA (8/20μs)	-	5	-	-	5	-	-	5	-	-	shots
AC Current	10x 1sec @ 60Hz	-	-	-	20	-	-	20	-	-	20	A
AC Follow-on Current	1/2 cycle @ 60Hz	-	-	-	20	-	-	20	-	-	20	A pk
DC Holdover Voltage	per REA PE-80, 0.2A	-	-	90	-	-	150	-	-	150	-	V

PARAMETER	CONDITIONS	SYMBOL	CG2-300			CG2-350			CG2-470			UNITS
			MIN	TYP	MAX	MIN	TYP	MAX	MIN	TYP	MAX	
Device Specifications												
DC Breakdown	500V/s	V _{BD}	255	300	345	297	350	403	400	470	540	V
Impulse Breakdown	100V/μs	V _{bd}	- ¹⁰	-	700	- ¹⁰	-	750	- ¹⁰	-	850	V
Insulation Resistance	100V	IR	10	-	-	10	-	-	10	-	-	Ω
Capacitance	1MHz	C	-	-	1	-	-	1	-	-	1	pF
Arc Voltage	I=5A min	V _{ARC}	-	15	-	-	15	-	-	15	-	V
Life Ratings⁽¹⁾												
Surge Life	500A (10/1000μs)	-	1000	-	-	1000	-	-	1000	-	-	shots
Max Current Surge	20kA (8/20μs)	-	5	-	-	5	-	-	5	-	-	shots
AC Current	10x 1sec @ 60Hz	-	-	-	20	-	-	20	-	-	20	A
AC Follow-on Current	1/2 cycle @ 60Hz	-	-	-	20	-	-	20	-	-	20	A pk
DC Holdover Voltage	per REA PE-80, 0.2A	-	-	150	-	-	150	-	-	150	-	V

PARAMETER	CONDITIONS	SYMBOL	CG2-600			CG2-800			CG2-1000			UNITS
			MIN	TYP	MAX	MIN	TYP	MAX	MIN	TYP	MAX	
Device Specifications												
DC Breakdown	500V/s	V _{BD}	510	600	690	680	800	920	850	1000	1150	V
Impulse Breakdown	100V/μs	V _{bd}	- ¹⁰	-	1000	- ¹⁰	-	1200	- ¹⁰	-	1500	V
Insulation Resistance	100V	IR	10	-	-	10	-	-	10	-	-	Ω
Capacitance	1MHz	C	-	-	1	-	-	1	-	-	1	pF
Arc Voltage	I=5A min	V _{ARC}	-	15	-	-	15	-	-	15	-	V
Life Ratings⁽¹⁾												
Surge Life	500A (10/1000μs)	-	1000	-	-	1000	-	-	1000	-	-	shots
Max Current Surge	10kA (8/20μs)	-	10	-	-	10	-	-	10	-	-	shots
AC Current	10x 1sec @ 60Hz	-	-	-	20	-	-	20	-	-	20	A
AC Follow-on Current	1/2 cycle @ 60Hz	-	-	-	20	-	-	20	-	-	20	A pk
DC Holdover Voltage	per REA PE-80, 0.2A	-	-	150	-	-	150	-	-	150	-	V

⁽¹⁾End-of-Life limits are: DC: 50% of minimum initial DC breakdown voltage limit to 150% of maximum initial DC breakdown voltage limit
Impulse: less than 150% of initial Impulse breakdown voltage limit.



TWO ELECTRODE SURGE ARRESTERS

CG/CG2 Series

PERFORMANCE CHARACTERISTICS

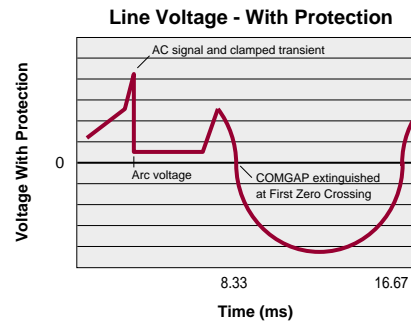
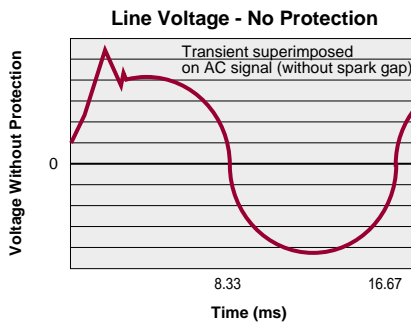
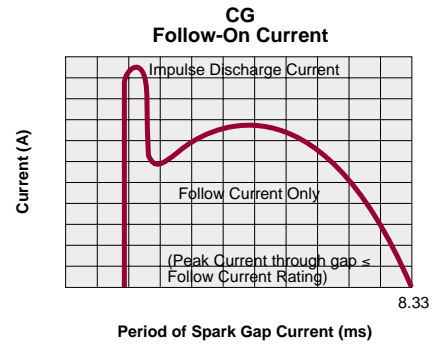
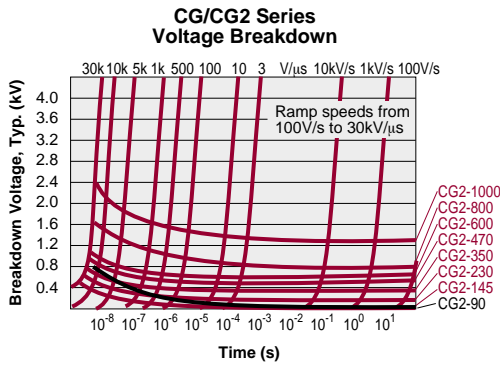

TWO ELECTRODE SURGE ARRESTERS

CG/CG2 Series

MECHANICAL DIMENSIONS

Other lead forms are available upon request.
Contact ClareREMtech for more information.

DIMENSIONS
mm
(inches)

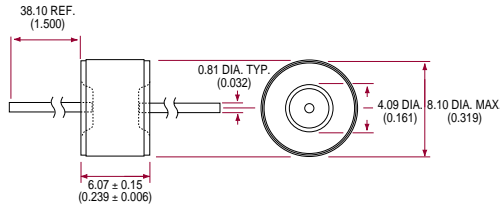

LS Outline

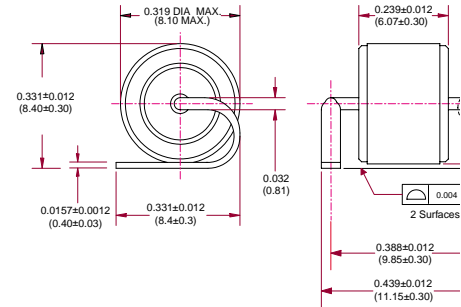

LS Recommended Land Pattern

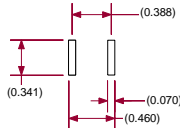

LS Tape & Reel Packaging

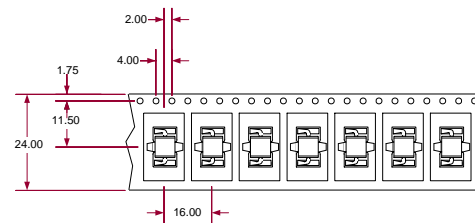

Tape & Reel packaging is available on request. See ordering information below for part number structure.

ORDERING INFORMATION

Tape & Reel Information

CGXXXLTR - Tape & Reel per EIA RS-296-D. Quantity = 1,000/Reel

CGXXXLTE - Tape & Reel per IEC286-1. Quantity = 1,000/Reel

CGXXXLSTR - See figure above for tape & reel information. Quantity = 1,400/Reel

CG/CG2's with other breakdown voltages in the 75-1000 V range are available upon request. A complete part number is represented by the digits below. For example, CG75 is a non-leaded 75V device, CG2-230L is a leaded 230V device, and CG2-800LTR is a leaded 800V device on tape-and-reel per EIA standard RS-296-D.

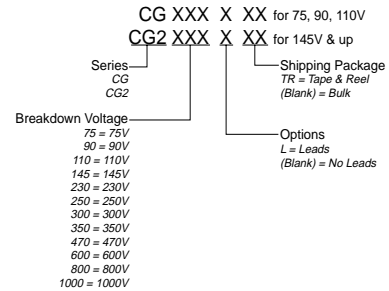

www.REMtechcorp.com

533

TWO ELECTRODE NON-RADIOACTIVE SURGE ARRESTERS

CG/CG2 SN Series

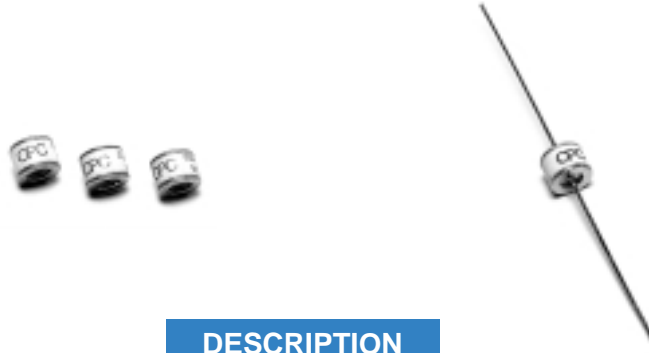

DESCRIPTION

ClareREMtech's two electrode non-radioactive CG/CG2 SN Comgaps are designed for use in surge protection applications for which the radioactive isotope used in the standard CG/CG2 Series (75-470V) is not desired. The gas-filled, rugged ceramic-metal construction of Comgaps makes them well suited to adverse environments. Comgaps function as switches which dissipate a minimum amount of energy and therefore handle currents that far surpass other types of transient voltage protection.

FEATURES

- Small size
- Rugged ceramic-metal construction
- Non-radioactive
- Low capacitance (<1pF)
- Available with or without leads
- Available in tape-and-reel packaging

APPLICATIONS

- Communication lines
- CATV equipment
- Test equipment
- Power supplies
- Medical electronics
- Instrumentation circuits

APPROVALS

- Meets REA PE-80
- Designed to meet CCITT-K12

RATINGS (@ 25° C)

Parameter	Min	Typ	Max	Units
DC Breakdown Voltage	72	90	108	V
184	230	276	V	
200	250	300	V	
240	300	360	V	
280	350	420	V	
376	470	564	V	
Insulation Resistance	10 ⁹	-	-	Ω
Capacitance	-	-	1	pF
Operational Temp	-40	-	+125	°C

(See detailed specifications for more information.)

TWO ELECTRODE NON-RADIOACTIVE SURGE ARRESTERS

CG/CG2 SN Series

SPECIFICATIONS

All characteristics at 25°C

PARAMETER	CONDITIONS	SYMBOL	CG90SN			CG2-230SN			CG2-250SN			UNITS
			MIN	TYP	MAX	MIN	TYP	MAX	MIN	TYP	MAX	
Device Specifications												
DC Breakdown	500V/s	V _{BD}	72	90	113	184	230	276	200	250	300	V
Impulse Breakdown	100V/μs	V _{BD}	-	-	500	-	-	600	-	-	600	V
Insulation Resistance	100V	IR	10 ⁹	-	-	10 ⁹	-	-	10 ⁹	-	-	Ω
Capacitance	1MHz	C	-	-	1	-	-	1	-	-	1	pF
Arc Voltage	1=5A min	V _{ARC}	-	10	-	-	10	-	-	10	-	V
Life Ratings⁽¹⁾												
Surge Life	500A (10/1000μs)	-	400	-	-	400	-	-	400	-	-	shots
Max Current Surge	10kA (8/20μs)	-	10	-	-	10	-	-	10	-	-	shots
AC Current	10x 1sec @ 60Hz	-	-	-	20	-	-	20	-	-	20	A
AC Follow-on Current	1/2 cycle @ 60Hz	-	-	-	N/A	-	-	20	-	-	20	A pk
DC Holdover Voltage	per REA PE-80, 0.2A	-	-	65	-	-	150	-	-	150	-	V

PARAMETER	CONDITIONS	SYMBOL	CG2-300SN			CG2-350SN			CG2-470SN			UNITS
			MIN	TYP	MAX	MIN	TYP	MAX	MIN	TYP	MAX	
Device Specifications												
DC Breakdown	500V/s	V _{BD}	240	300	360	280	350	420	376	470	564	V
Impulse Breakdown	100V/μs	V _{BD}	-	-	700	-	-	750	-	-	850	V
Insulation Resistance	100V	IR	10 ⁹	-	-	10 ⁹	-	-	10 ⁹	-	-	Ω
Capacitance	1MHz	C	-	-	1	-	-	1	-	-	1	pF
Arc Voltage	1=5A min	V _{ARC}	-	10	-	-	10	-	-	10	-	V
Life Ratings⁽¹⁾												
Surge Life	500A (10/1000μs)	-	400	-	-	400	-	-	400	-	-	shots
Max Current Surge	10kA (8/20μs)	-	10	-	-	10	-	-	10	-	-	shots
AC Current	10x 1sec @ 60Hz	-	-	-	20	-	-	20	-	-	20	A
AC Follow-on Current	1/2 cycle @ 60Hz	-	-	-	20	-	-	20	-	-	20	A pk
DC Holdover Voltage	per REA PE-80, 0.2A	-	-	150	-	-	150	-	-	150	-	V

⁽¹⁾End-of-life limits are:

DC: 50% of minimum initial DC breakdown voltage limit to 150% of maximum initial DC breakdown voltage limit.

Impulse: less than 150% of initial Impulse breakdown voltage limit.

TWO ELECTRODE NON-RADIOACTIVE SURGE ARRESTERS

CG/CG2 SN Series

MECHANICAL DIMENSIONS

Other lead forms are available upon request.
Contact ClareREMtech for more information.

DIMENSIONS
mm
(inches)

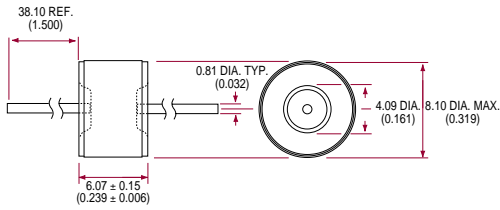

LS Outline

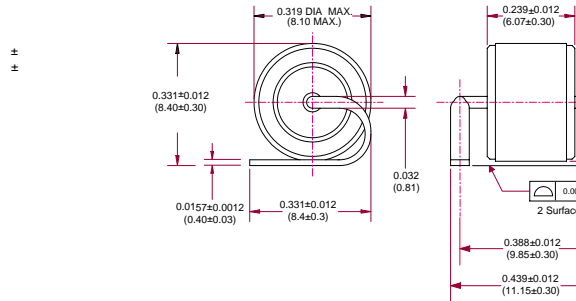

LS Recommended Land Pattern

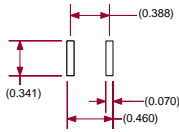

LS Tape & Reel Packaging

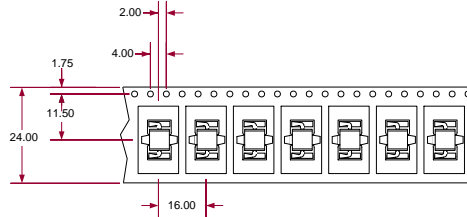

Tape & Reel packaging is available on request. See ordering information below for part number structure.

ORDERING INFORMATION

CG/CG2 SN's with other breakdown voltages in the 90-470 V range are available upon request. A complete part number is represented by the digits below. For example, CG2-230SN is a non-leaded 230V device, CG2-470LSN is a leaded 470V device, and CG90LSNTR is a leaded 90V device on tape-and-reel per EIA standard RS-296-D.

Tape & Reel Information

CGXXXLSNTR - Tape & Reel per EIA RS-296-D. Quantity = 1,000/Reel

CGXXXLSNTE - Tape & Reel per IEC286-1. Quantity = 1,000/Reel

CGXXXLSSNTR - See figure above for tape & reel information. Quantity = 1,400/Reel

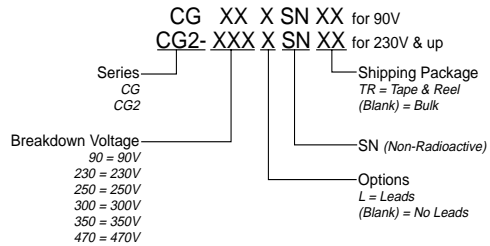

TWO ELECTRODE HIGH VOLTAGE SURGE ARRESTERS

CG3 Series

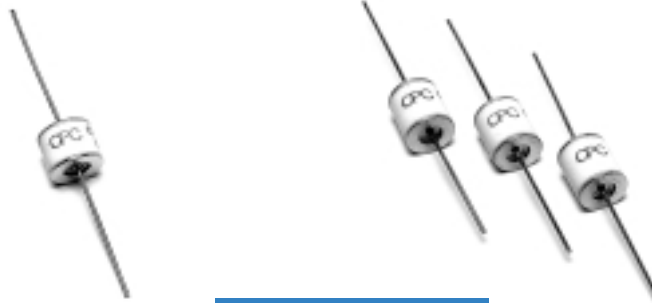

DESCRIPTION

ClareREMtech's two electrode high voltage CG3 Comgaps (1.0 - 8.5 kV) are designed for surge protection in applications for which bias voltages or signal levels of several hundred volts are normally present. Comgaps function as switches which dissipate a minimum amount of energy and therefore handle currents that far surpass other types of transient voltage protection.

- Small size

FEATURES

- Rugged ceramic-metal construction
- Non-radioactive
- Low capacitance (<1pF)
- Available in tape-and-reel packaging
- Available with or without leads
- UL Recognized: File Number E111526

APPROVALS

- UL Recognized: File Number E145934 (CG3XUHTZ only)
- CSA Approved: File Number LR89617

APPLICATIONS

- CRT terminal
- CATV equipment
- Antennas
- Power supplies
- Medical electronics

RATINGS (@ 25° C)

Parameter	Min	Typ	Max	Unit
DC Breakdown Voltage	800	1000	1200	V
	1200	1500	1800	V
	1600	2000	2400	V
	2000	2500	3000	V
	2400	3000	3600	V
	3200	4000	4800	V
	4000	5000	6000	V
	6000	7500	9000	V
	6800	8500	10200	V
Insulation Resistance	10 ¹⁰	-	-	Ω
Capacitance	-	-	1	pF
Operational Temperature	-40	-	+125	°C

(See detailed specifications for more information.)

TWO ELECTRODE HIGH VOLTAGE SURGE ARRESTERS

CG3 Series

SPECIFICATIONS

All characteristics at 25°C

PARAMETER	CONDITIONS	SYMBOL	CG3-1.0			CG3-1.5			UNITS
			MIN	TYP	MAX	MIN	TYP	MAX	
Device Specifications									
DC Breakdown	500V/s	V _{BD}	800	1000	1200	1200	1500	1800	V
Impulse Breakdown	100V/μs	V _{BD}	-	-	1500	-	-	2200	V
Insulation Resistance	100V	IR	10 ¹⁰	-	-	10 ¹⁰	-	-	Ω
Capacitance	1MHz	C	-	-	1	-	-	1	pF
Arc Voltage	I=5A min	V _{ARC}	-	10	-	-	10	-	V
Mechanical Outline		-	-	A	-	-	A	-	-
Life Ratings⁽¹⁾									
Surge Life	.002mF, 100Ω	-	500	-	-	500	-	-	shots
Max Current Surge	10kA (8/20μs)	-	5	-	-	5	-	-	shots
AC Follow-on Current	1/2 cycle @ 60Hz	-	-	-	300	-	-	300	A pk

CG3-2.0 CG3-2.5 CG3-2.0L CG3-2.5L

PARAMETER	CONDITIONS	SYMBOL	CG3-2.0			CG3-2.5			UNITS
			MIN	TYP	MAX	MIN	TYP	MAX	
Device Specifications									
DC Breakdown	500V/s	V _{BD}	1600	2000	2400	2000	2500	3000	V
Impulse Breakdown	100V/μs	V _{BD}	-	-	3000	-	-	3750	V
Insulation Resistance	100V	IR	10 ¹⁰	-	-	10 ¹⁰	-	-	Ω
Capacitance	1MHz	C	-	-	1	-	-	1	pF
Arc Voltage	I=5A min	V _{ARC}	-	10	-	-	10	-	V
Mechanical Outline		-	-	A	-	-	A	-	-
Life Ratings⁽¹⁾									
Surge Life	.002mF, 100Ω	-	500	-	-	500	-	-	shots
Max Current Surge	10kA (8/20μs)	-	5	-	-	5	-	-	shots
AC Follow-on Current	1/2 cycle @ 60Hz	-	-	-	300	-	-	300	A pk

CG3-3.0 CG3-4.0 CG3-3.0L CG3-4.0L

PARAMETER	CONDITIONS	SYMBOL	CG3-3.0			CG3-4.0			UNITS
			MIN	TYP	MAX	MIN	TYP	MAX	
Device Specifications									
DC Breakdown	500V/s	V _{BD}	2400	3000	3600	3200	4000	4800	V
Impulse Breakdown	100V/μs	V _{BD}	-	-	4500	-	-	6000	V
Insulation Resistance	100V	IR	10 ¹⁰	-	-	10 ¹⁰	-	-	Ω
Capacitance	1MHz	C	-	-	1	-	-	1	pF
Arc Voltage	I=5A min	V _{ARC}	-	10	-	-	10	-	V
Mechanical Outline		-	-	B	-	-	B	-	-
Life Ratings⁽¹⁾									
Surge Life	.002mF, 100W	-	500	-	-	500	-	-	shots
Max Current Surge	10kA (8/20μs)	-	5	-	-	5	-	-	shots
AC Follow-on Current	1/2 cycle @ 60Hz	-	-	-	300	-	-	300	A pk

(1)End-of-life limits are:

DC: 50% of minimum initial DC breakdown voltage limit to 150% of maximum initial DC breakdown voltage limit.

Impulse: less than 150% of initial impulse breakdown voltage limit.

TWO ELECTRODE HIGH VOLTAGE SURGE ARRESTERS

CG3 Series

SPECIFICATIONS

PARAMETER	CONDITIONS	SYMBOL	CG3-5.0			CG3-7.5			CG3-8.5			UNITS
			MIN	TYP	MAX	MIN	TYP	MAX	MIN	TYP	MAX	
All characteristics at 25°C												
Device Specifications												
DC Breakdown	500V/s	V _{BD}	4000	5000	6000	6000	7500	9000	6800	8500	10200	V
Impulse Breakdown	100V/μs	V _{BD}	-	-	7500	-	-	10000	-	-	13500	V
Insulation Resistance	100V	IR	10 ¹⁰	-	-	10 ¹⁰	-	-	10 ¹⁰	-	-	Ω
Capacitance	1MHz	C	-	-	1	-	-	1	-	-	1	pF
Arc Voltage	I=5A min	V _{ARC}	-	10	-	-	10	-	-	10	-	V
Mechanical Outline			-	B	-	-	B	-	-	B	-	-
Life Ratings⁽¹⁾												
Surge Life	.002mF, 100Ω	-	500	-	-	500	-	-	500	-	-	shots
Max Current Surge	10kA (8/20μs)	-	5	-	-	5	-	-	5	-	-	shots
AC Follow-on Current	¹ / ₂ cycle @ 60Hz	-	-	-	300	-	-	300	-	-	300	A pk

⁽¹⁾End-of-life limits are:

DC: 50% of minimum initial DC breakdown voltage limit to 150% of maximum initial DC breakdown voltage limit.
 Impulse: less than 150% of initial impulse breakdown voltage limit.

MECHANICAL DIMENSIONS

Other lead forms are available upon request.
 Contact ClareREMtech for more information.

Outline A

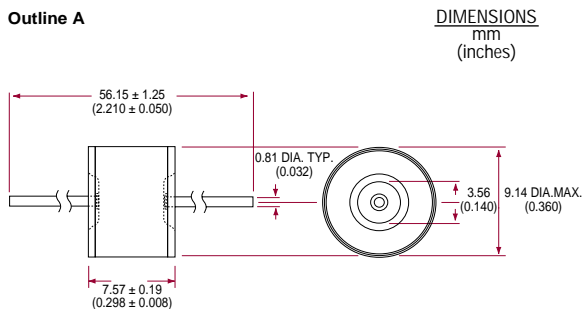

Outline B

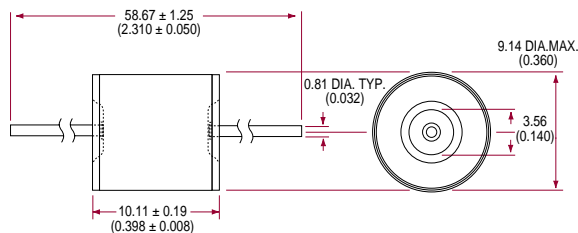

ORDERING INFORMATION

CG3's with other breakdown voltages in the 1.0-8.5kV range are available upon request. A complete part number is represented by the digits below. For example, CG3-1.5 is a non-leaded 1500V device, CG3-5.0L is a leaded 5000V device, and CG3-7.5LTR is a leaded 7500V device on tape-and-reel per EIA standard RS-296-D.

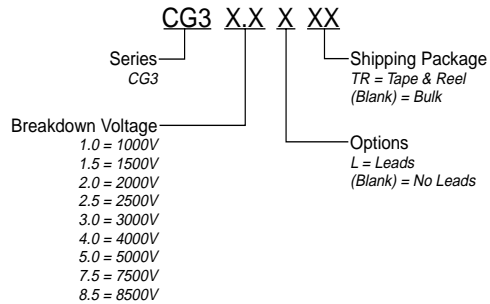

Tape & Reel Information

CG3XLTR - Tape & Reel per EIA RS-296-D. Quantity = 1,000/Reel

CG3XLTE - Tape & Reel per IEC286-1. Quantity = 1,000/Reel



www.REMtechcorp.com

TWO ELECTRODE MINI SURGE ARRESTERS

CG5 Series



DESCRIPTION

ClareREMtech's two electrode mini CG5 Comgaps are gas filled, non-radioactive surge protectors. These devices are physically smaller than Clare's standard CG/CG2 series reducing the space required to provide high performance circuit protection. The CG5 series can be supplied with or without leads. These components are used in a variety of different applications, including telecom and CATV communication lines. The small CG5 gas tubes function as switches which dissipate a minimum amount of energy and therefore handle currents that far surpass other types of transient voltage protection.

■ Smallest CG

FEATURES

- Non-radioactive
- Rugged ceramic-metal construction
- Low capacitance (<1pF)
- Available with or without leads
- Available in tape-and-reel packaging

- Telecom lines

APPLICATIONS

- CATV equipment
- Test equipment
- Data lines
- Instrumentation circuits

RATINGS (@ 25° C)

Parameter	Min	Typ	Max	Units
DC Breakdown Voltage	72	90	113	V
	184	230	276	V
	280	350	420	V
Insulation Resistance	10 ¹⁰	-	-	Ω
Capacitance	-	-	1	pF
Operational Temperature	-40	-	+125	°C

(See detailed specifications for more information.)

TWO ELECTRODE MINI SURGE ARRESTERS

CG5 Series

SPECIFICATIONS

PARAMETERS	CONDITIONS	SYMBOL	CG5-90 CG5-90L			CG5-230 CG5-230L			CG5-350 CG5-350L			UNITS
			MIN	TYP	MAX	MIN	TYP	MAX	MIN	TYP	MAX	
<i>All characteristics at 25°C</i>												
Device Specifications												
DC Breakdown	500V/s	V _{BD}	72	90	113	184	230	276	280	350	420	V
Impulse Breakdown	100V/μs	V _{BD}	-	-	500	-	-	500	-	-	600	V
	1kV/μs	V _{BD}	-	-	700	-	-	700	-	-	800	V
Insulation Resistance	50V	IR	10 ¹⁰	-	-	10 ¹⁰	-	-	10 ¹⁰	-	-	Ω
Capacitance	1MHz	C	-	-	1	-	-	1	-	-	1	pF
Arc Voltage	I=5A min	V _{ARC}	-	25	-	-	25	-	-	25	-	V
Life Ratings⁽¹⁾												
Surge Life	100A (10/1000μs)	-	300	-	-	300	-	-	300	-	-	shots
Max Current Surge	5kA (8/20μs)	-	10	-	-	10	-	-	10	-	-	shots
AC Current	10x 1sec @ 60Hz	-	-	-	5	-	-	5	-	-	5	A

(1) End-of-Life limits are:

DC: 50% of minimum initial DC Breakdown Voltage limit to 150% of maximum initial DC Breakdown Voltage limit.

Impulse: less than 150% of initial impulse Breakdown Voltage limit.

HEAVY DUTY SURGE ARRESTERS

CG5 Series

MECHANICAL DIMENSIONS

Other lead forms are available upon request.
Contact ClareREMtech for more information.

DIMENSIONS
mm
(inches)



LS Outline

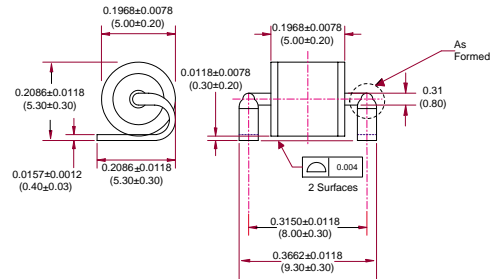

LS Recommended Land Pattern

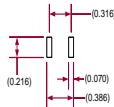

LS Tape & Reel Packaging

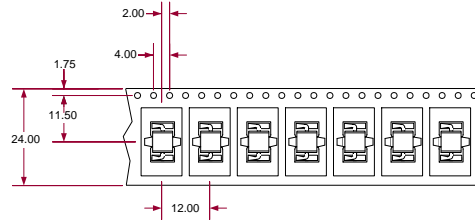

Tape & Reel packaging is available on request. See ordering information below for part number structure.

ORDERING INFORMATION

A complete part number is represented by the digits below.
For example, CG5-90 is a non-leaded 90V device, CG5-230L is a leaded 230V device, and CG5-350LTR is a leaded 350V device on tape-and-reel per EIA standard RS-296-D.

Tape & Reel Information

CG5XXXLTR - Tape & Reel per EIA RS-296-D. Quantity = 1,000/Reel

CG5XXXLTE - Tape & Reel per IEC286-1. Quantity = 1,000/Reel

CG5XXXLSTR - See figure above for tape & reel information. Quantity = 2,900/Reel

