

# User Manual

## SmartSens 3D MagIC

Sensor Controller ASIC



## Table of Contents

<b>1</b>	<b>COPYRIGHT &amp; WARRANTY INFORMATION .....</b>	<b>4</b>
<b>2</b>	<b>INTRODUCTION .....</b>	<b>5</b>
<b>3</b>	<b>SPECIFICATIONS .....</b>	<b>6</b>
3.1	DEVICE CHARACTERISTICS .....	6
3.2	TYPICAL OPERATING CHARACTERISTICS .....	8
3.3	DIMENSIONS AND PACKAGING .....	9
3.4	SOLDERING .....	12
<b>4</b>	<b>OVERVIEW AND PIN-OUT .....</b>	<b>13</b>
4.1	OVERVIEW .....	13
4.2	IDLE MODE .....	15
4.3	3D MAGIC PINOUT AND CONNECTIONS .....	15
<b>5</b>	<b>SPI INTERFACE .....</b>	<b>17</b>
5.1	SPI PINS .....	17
5.1.1	SCLK (Serial Clock Input) .....	17
5.1.2	SSN (Slave Select) .....	17
5.1.3	MISO (Serial Out) .....	17
5.1.4	MOSI (Serial In) .....	17
5.2	HARDWARE HANDSHAKING PINS .....	18
5.2.1	DRDY (Data Ready) .....	18
5.2.2	CLEAR (Clear Command Register) .....	18
5.3	SPI INTERFACE OPERATION .....	18
<b>6</b>	<b>OPERATION – STANDARD MODE .....</b>	<b>21</b>
6.1	COMMAND REGISTER .....	21
6.1.1	Initiate Sensor Measurement .....	21
6.1.2	Read/Write to a Cycle Count Register .....	22
6.2	CYCLE COUNT REGISTERS .....	22
6.3	MAKING A MEASUREMENT .....	23
<b>7</b>	<b>OPERATION – LEGACY MODE .....</b>	<b>25</b>
7.1	COMMAND REGISTER .....	25
7.1.1	Initiate Sensor Measurement .....	25
7.1.2	Read/Write to Clock Set Register .....	26
7.2	CLOCK SET REGISTER .....	27
7.2.1	Clock Divide .....	27
7.2.2	Period Divide .....	28
7.3	MAKING A MEASUREMENT .....	29

## List of Figures

Figure 3-1: Gain vs. Cycle Counts.....	8
Figure 3-2: Maximum Data Rate per Axis vs. Cycle Counts .....	8
Figure 3-3: 3D MagIC MLF Mechanical Drawing .....	9
Figure 3-4: 3D MagIC MLF Tape Dimensions.....	10
Figure 3-5: 3D MagIC Die Pad Layout .....	10
Figure 3-6: Example Wire Bonding Layout for Legacy 11096 ASIC Applications.....	11
Figure 3-7: Recommended Solder Reflow Profile .....	12
Figure 4-1: Typical 3D MagIC MLF Application Circuit .....	13
Figure 4-2: Biasing Diagram.....	14
Figure 5-1: SPI Measure/Read Data Timing Diagram – Standard Mode.....	19
Figure 5-2: SPI Measure/Read Data Timing Diagram – Legacy Mode.....	19
Figure 5-3: SPI Read/Write Data Timing.....	20

## List of Tables

Table 3-1: Absolute Maximum Ratings .....	6
Table 3-2: Recommended Operating Conditions .....	6
Table 3-3: Electrical Characteristics .....	7
Table 3-4: Recommended Solder Processing Parameters.....	12
Table 4-1: 3D MagIC Pin Assignments .....	16
Table 5-1: Timing Specifications .....	20
Table 6-1: Cycle Count Registers.....	23

# 1 Copyright & Warranty Information

© Copyright PNI Sensor Corporation 2010

All Rights Reserved. Reproduction, adaptation, or translation without prior written permission is prohibited, except as allowed under copyright laws.

Revised April 2010: for the most recent version visit our website at [www.pnicorp.com](http://www.pnicorp.com)

PNI Sensor Corporation  
133 Aviation Blvd, Suite 101  
Santa Rosa, CA 95403, USA  
Tel: (707) 566-2260  
Fax: (707) 566-2261

**Warranty and Limitation of Liability.** PNI Sensor Corporation ("PNI") manufactures its Products from parts and components that are new or equivalent to new in performance. PNI warrants that each Product to be delivered hereunder, if properly used, will, for ninety (90) days following the date of shipment unless a different warranty time period for such Product is specified: (i) in PNI's Price List in effect at time of order acceptance; or (ii) on PNI's web site ([www.pnicorp.com](http://www.pnicorp.com)) at time of order acceptance, be free from defects in material and workmanship and will operate in accordance with PNI's published specifications and documentation for the Product in effect at time of order. PNI will make no changes to the specifications or manufacturing processes that affect form, fit, or function of the Product without written notice to the Customer, however, PNI may at any time, without such notice, make minor changes to specifications or manufacturing processes that do not affect the form, fit, or function of the Product. This warranty will be void if the Products' serial number, or other identification marks have been defaced, damaged, or removed. This warranty does not cover wear and tear due to normal use, or damage to the Product as the result of improper usage, neglect of care, alteration, accident, or unauthorized repair. THE ABOVE WARRANTY IS IN LIEU OF ANY OTHER WARRANTY, WHETHER EXPRESS, IMPLIED, OR STATUTORY, INCLUDING, BUT NOT LIMITED TO, ANY WARRANTY OF MERCHANTABILITY, FITNESS FOR ANY PARTICULAR PURPOSE, OR ANY WARRANTY OTHERWISE ARISING OUT OF ANY PROPOSAL, SPECIFICATION, OR SAMPLE. PNI NEITHER ASSUMES NOR AUTHORIZES ANY PERSON TO ASSUME FOR IT ANY OTHER LIABILITY.

If any Product furnished hereunder fails to conform to the above warranty, Customer's sole and exclusive remedy and PNI's sole and exclusive liability will be, at PNI's option, to repair, replace, or credit Customer's account with an amount equal to the price paid for any such Product which fails during the applicable warranty period provided that (i) Customer promptly notifies PNI in writing that such Product is defective and furnishes an explanation of the deficiency; (ii) such Product is returned to PNI's service facility at Customer's risk and expense; and (iii) PNI is satisfied that claimed deficiencies exist and were not caused by accident, misuse, neglect, alteration, repair, improper installation, or improper testing. If a Product is defective, transportation charges for the return of the Product to Customer within the United States and Canada will be paid by PNI. For all other locations, the warranty excludes all costs of shipping, customs clearance, and other related charges. PNI will have a reasonable time to make repairs or to replace the Product or to credit Customer's account. PNI warrants any such repaired or replacement Product to be free from defects in material and workmanship on the same terms as the Product originally purchased.

Except for the breach of warranty remedies set forth herein, or for personal injury, PNI shall have no liability for any indirect or speculative damages (including, but not limited to, consequential, incidental, punitive and special damages) relating to the use of or inability to use this Product, whether arising out of contract, negligence, tort, or under any warranty theory, or for infringement of any other party's intellectual property rights, irrespective of whether PNI had advance notice of the possibility of any such damages, including, but not limited to, loss of use, revenue or profit. In no event shall PNI's total liability for all claims regarding a Product exceed the price paid for the Product. PNI neither assumes nor authorizes any person to assume for it any other liabilities.

Some states and provinces do not allow limitations on how long an implied warranty lasts or the exclusion or limitation of incidental or consequential damages, so the above limitations or exclusions may not apply to you. This warranty gives you specific legal rights and you may have other rights that vary by state or province.

## 2 Introduction

Thank you for purchasing PNI Sensor Corporation's SmartSens 3D MagIC. The 3D MagIC is a control and measurement ASIC for use with PNI's SmartSens magneto-inductive (MI) sensors (the Sen-XY and Sen-Z), and represents a dramatic step forward in terms of data rate and power consumption when compared to PNI's prior legacy ASIC. It contains drive and measurement circuitry for interaction with SmartSens sensors, interface circuitry to communicate with a host microprocessor on an SPI bus, an internal clock and inputs for a user-supplied external clock or crystal oscillator. The 3D MagIC can control and measure three independent SmartSens sensors. Each SmartSens sensor is individually selectable for measurement, and can be individually configured for measurement resolution

For most applications the SmartSens MI sensor serves as the inductive element in a simple LR relaxation oscillation circuit, with its effective inductance proportional to the magnetic field parallel to the sensor axis. When driven by the 3D MagIC, the frequency of oscillation varies with the strength of the magnetic field parallel to the sensor.

The output from the 3D MagIC is inherently digital and can be fed directly into a microprocessor, which eliminates the need for signal conditioning or an analog/digital interface between the sensor and a microprocessor. The simplicity of the SmartSens circuit combined with the lack of signal conditioning makes it easier and less expensive to implement than alternative fluxgate or magneto-resistive (MR) technologies.

Since the SmartSens circuit works in the frequency domain, resolution and noise are established cleanly by the number of cycle counts. In comparison, fluxgate and MR technologies require expensive and complex signal processing to obtain similar resolution and noise, and for certain applications the SmartSens solution cannot be matched.

## 3 Specifications

### 3.1 Device Characteristics

**Table 3-1: Absolute Maximum Ratings**

Parameter	Symbol	Minimum	Maximum	Units
Analog/Digital DC Supply Voltage	$V_{DD}, V_{DD}$	-0.3	+3.7	VDC
Input Pin Voltage	$V_{IN}$	-0.3	$V_{DD}$ or $V_{DD}$	VDC
Input Pin Current @ 25C	$I_{IN}$	-10.0	+10.0	mA
Storage Temperature	$T_{STRG}$	-40°	+125°	C

**CAUTION:**

Stresses beyond those listed above may cause permanent damage to the device. These are stress ratings only. Functional operation of the device at these or any other conditions beyond those indicated in the operational sections of the specifications is not implied. Exposure to absolute maximum rating conditions for extended periods may affect device reliability.

**Table 3-2: Recommended Operating Conditions**

Parameter	Symbol	Min	Typ	Max	Units	
Analog/Digital DC Supply Voltage	$V_{DD}, V_{DD}$	1.6	3.3	3.6	VDC	
Supply Voltage Difference ( $V_{DD}-V_{DD}$ )	During Operation	$\Delta V_{DD\_OP}$	-0.1	0	+0.1	VDC
	Analog Unpowered	$\Delta V_{DD\_OFF}$	$V_{DD}-0.1$	$V_{DD}$	$V_{DD}+0.1$	VDC
Bias Resistance	$V_{DD} = 3.3 V$ $R_b$		68		$\Omega$	
External Timing Resistor for Clock	$R_{EXT}$		33		k $\Omega$	
Operating Temperature	$T_{OP}$	-40		+85	C	

**Table 3-3: Electrical Characteristics**

Parameter	Symbol	Min	Typ	Max	Units
Average Operating Current <sup>1,2</sup>	$I_{DDM}$		0.25		mA
Idle Mode Current	$I_{DDI}$			1	$\mu$ A
Leakage Current	$I_{DVDD}$			100	nA
High level input voltage	$V_{IH}$	$0.7*DV_{DD}$		$V_{DD}$	v
Low level input voltage	$V_{IL}$	0		$0.3*DV_{DD}$	v
High level output current	$I_{OH}$	1			mA
Low level output current	$I_{OL}$			-1	mA
Sensor Circuit Oscillation Frequency <sup>3</sup>	$SC_{OSC}$		185		kHz
Internal Oscillator Frequency	$OSC_{FREQ}$		45		MHz

**Note:**

- 1) Bias resistance is to be determined, but expected to be in the range of 50 $\Omega$  to 70 $\Omega$ .
- 2) Polling rate of 8 Hz, cycle count of 1024, and Fast Bias mode.
- 3) When 3D MagIC is used in conjunction with Sen-XY or Sen-Z sensor and appropriate bias resistor. Circuit oscillation frequency will vary depending on a number of factors including the strength of the ambient magnetic field.

## 3.2 Typical Operating Characteristics

Note that “Cycle Counts” is set by the user through the Cycle Count Registers in Standard Mode or the Counter Divide (CD) bits in the Legacy Mode’s Clock Set Register.

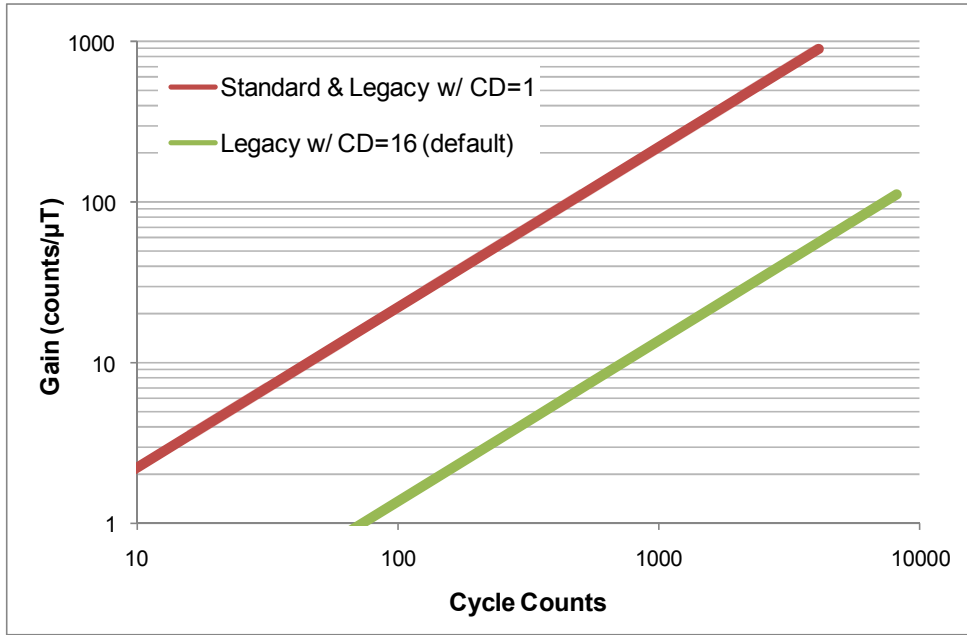

Figure 3-1: Gain vs. Cycle Counts  
(Resolution = 1/Gain, to the system’s noise limit)

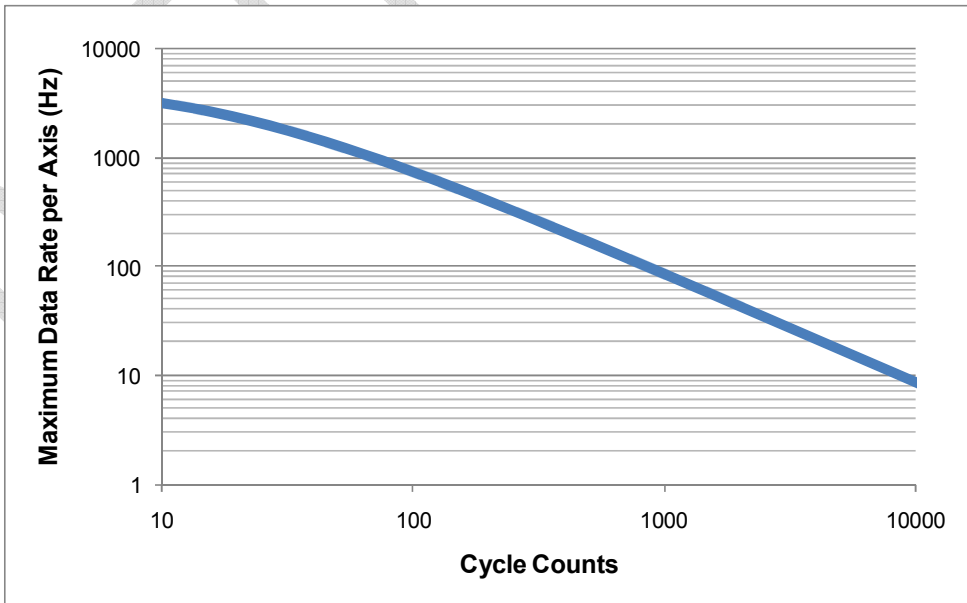

Figure 3-2: Maximum Data Rate per Axis vs. Cycle Counts



### 3.3 Dimensions and Packaging

Dimensions in mm.

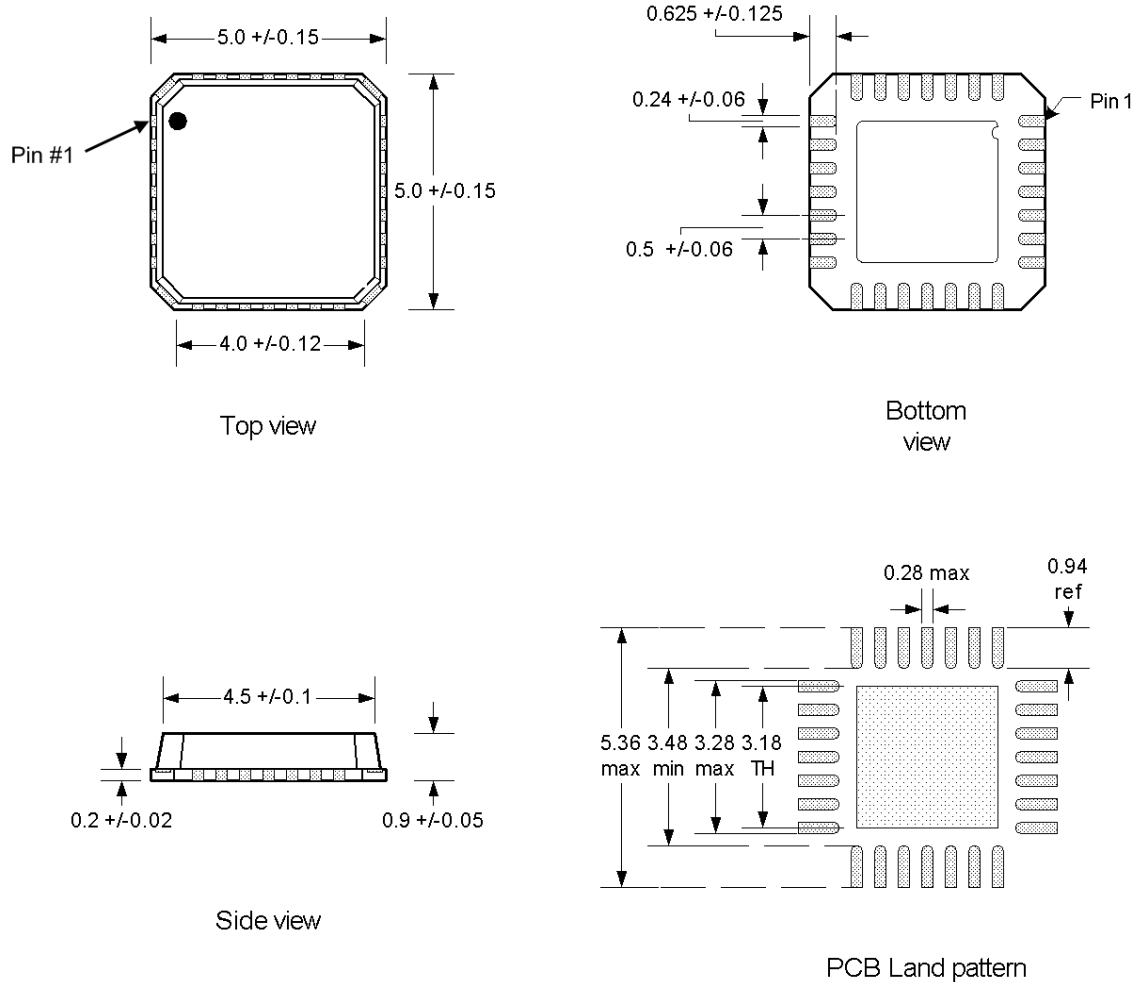
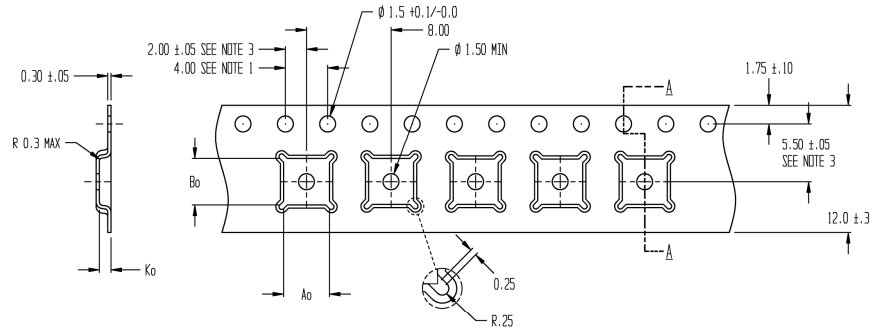

Figure 3-3: 3D MagIC MLF Mechanical Drawing



Notes:

1. 10 sprocket hole pitch cumulative tolerance  $\pm 0.2$
2. Camber in compliance with EIA 481
3. Pocket position relative to sprocket hole measured as true position of pocket, not pocket hole

$A_0 = 5.25$   
 $B_0 = 5.25$   
 $K_0 = 1.10$

5 thousand per reel

Tolerances - Unless Noted  
 1PL  $\pm 0.2$   
 2PL  $\pm 0.10$   
 All dimensions in millimeters

Figure 3-4: 3D MagIC MLF Tape Dimensions

Dimensions in  $\mu\text{m}$  (microns)

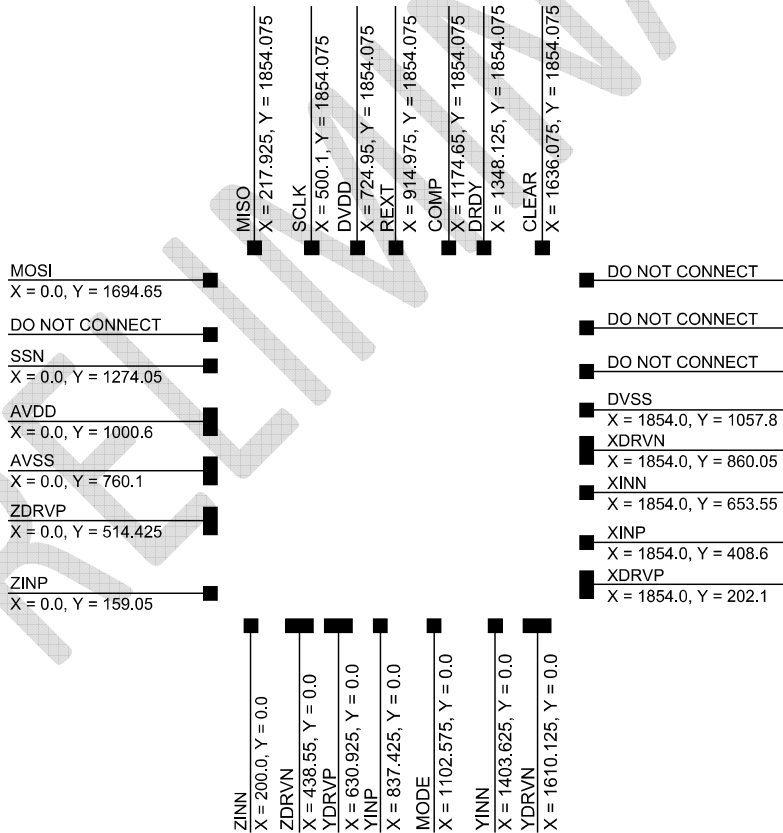

NOTES:

- The origin (0, 0) is the lower left coordinate of the center pads.  
 The chip size (2080.0  $\mu\text{m}$  x 2080.0  $\mu\text{m}$ ) is calculated using pad to scribe distance.

Figure 3-5: 3D MagIC Die Pad Layout

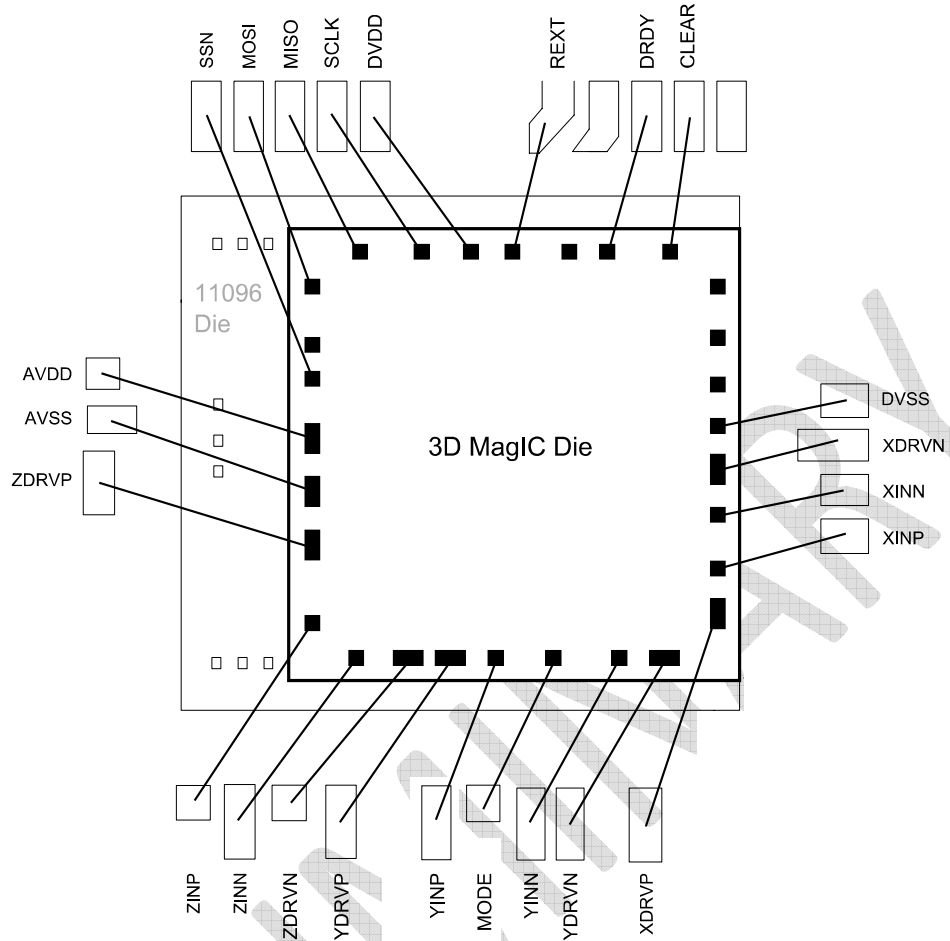

Figure 3-6: Example Wire Bonding Layout for Legacy 11096 ASIC Applications

Note that Figure 3-6 is for illustrative purposes only. The sample bond pad layout was taken from a PNI product. The customer's bond pad layout will vary, as will the best layout for the customer's application.

### 3.4 Soldering

**Table 3-4: Recommended Solder Processing Parameters**

Reflow Parameter	Temperature (C)	TIME (sec)
Preheat Temperature ( $T_{smin}$ To $T_{smax}$ )	150°C – 200°C	60-180
Temperature $T_L$ (Typical Lead-Free Solder Melting Point)	>218°C	
$T_{smax}$ To $T_L$ Ramp-Up Rate	3°C/Second Max	
Peak Temperature $T_p$	<260°C	
Time 25°C To Peak $T_p$	6 Minute Max	
Time Maintained Above Temperature $T_L$ ( $T_L$ )	218°C	60-120
Soak (Time Within 5° Of Actual Peak $T_p$ )		10-20
Rampdown Rate	4°C/Second Max	

a. Meets IPC/JEDEC J-STD-020 profile recommendations

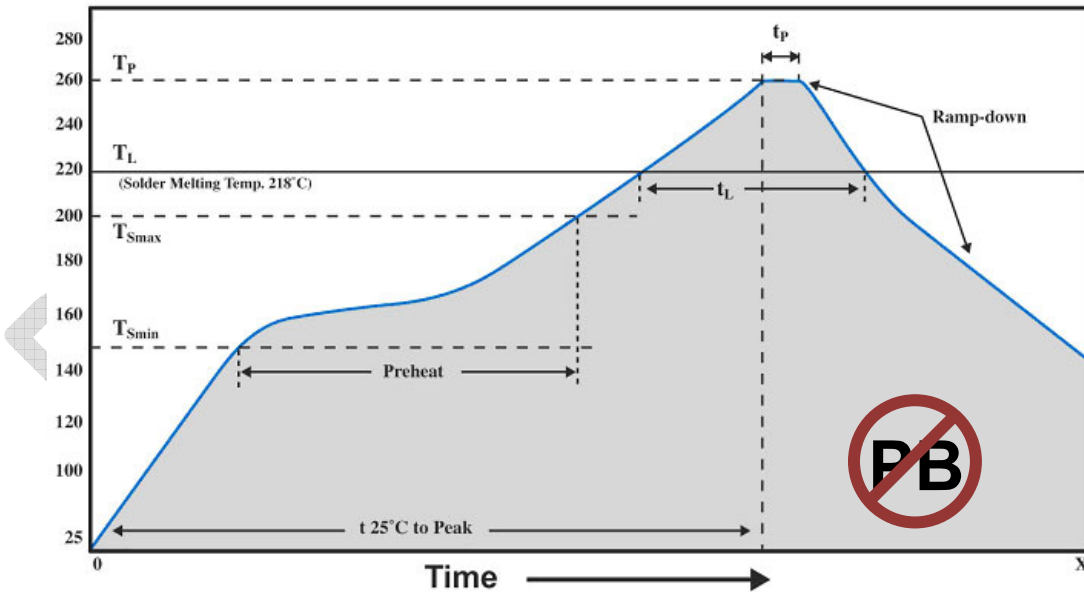

Figure 3-7: Recommended Solder Reflow Profile

## 4 Overview and Pin-Out

### 4.1 Overview

The 3D MagIC contains drive and measurement circuitry for controlling PNI's SmartSens magneto-inductive sensors, interface circuitry to communicate with a host microprocessor on an SPI bus, and an internal clock. It is intended as a component in a SmartSens magnetic sensing circuit, as show in Figure 4-1, with a detail of the biasing shown in Figure 4-2. The 3D MagIC can be used to interface from one to three sensors depending on application requirements.

*Note: The 3D MagIC typically is used in compassing applications, where each channel represents a Cartesian coordinate axis (x, y, or z). For this reason, the term "axis" often is used instead of channel throughout this document.*

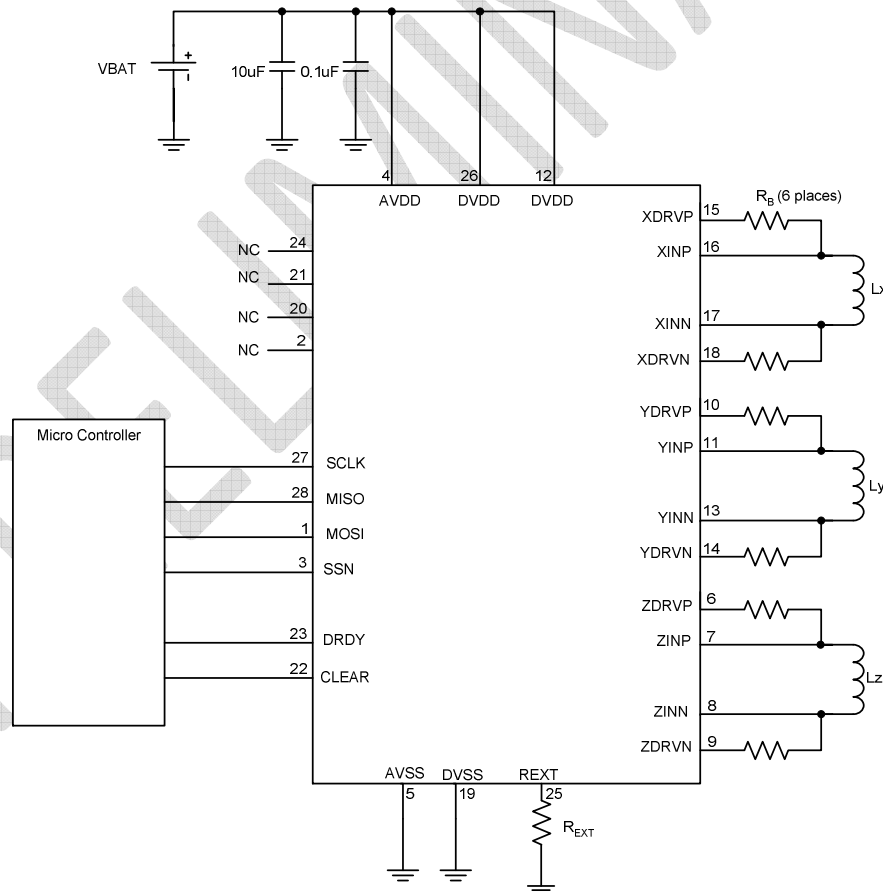

Figure 4-1: Typical 3D MagIC MLF Application Circuit

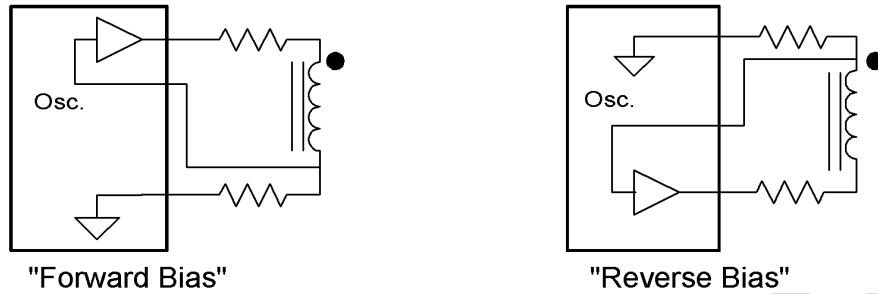

Figure 4-2: Biasing Diagram

A single 8 bit command from the host system configures and initiates an axis measurement from the 3D MagIC. The 3D MagIC can interface with one to three sensors depending on the application requirement. **Unused sensor connections should remain floating.** A magneto-inductive sensor operates in an oscillator circuit composed of an external bias resistor along with digital gates and a comparator internal to the 3D MagIC. Only one sensor can be measured at a time. To measure a sensor, a command byte is sent to the 3D MagIC through the SPI port specifying the axis to be measured. The time to complete a host-specified number of oscillation cycles is measured in both the forward and reverse bias directions. The 3D MagIC returns the difference between the two measurement times represented as a number in a 2's complement format, and this number is directly proportional to the direction and strength of the local magnetic field.

The 3D MagIC's output provides the difference in the high-speed oscillator cycles between the forward-biased and reverse-biased sensor measurements. To make a measurement, one side of the sensor is grounded while the other side is alternately driven with positive and negative current through the oscillator. The number of circuit oscillations (cycle counts) is user-defined in software and establishes how many oscillations of the RL circuit are desired per measurement. The greater the cycle counts, the higher the resolution of the measurement and the longer the sample time. The high-speed oscillator measures how long it takes to make the desired number cycle counts. The 3D MagIC next switches the bias connection to the sensor and makes another measurement. The side that was previously grounded is now charged and discharged while the other is now grounded.

---

## 4.2 Idle Mode

The 3D MagIC incorporates an Idle Mode to reduce power consumption, in which it automatically idles when it is not exchanging data or taking a measurement. Unlike the legacy 11096 ASIC, the 3D MagIC starts in the Idle Mode at power-up and remains in Idle Mode until a measurement is needed. Therefore, it is not necessary to cycle the 3D MagIC through one measurement request operation to ensure it is in Idle Mode, as was required by the legacy 11096 ASIC.

---

## 4.3 3D MagIC Pinout and Connections

The 3D MagIC's pinout is summarized in Table 4-1. Pin numbers run counterclockwise (when looking from the top), starting at the Pin 1 designator as shown in Figure 3-3.

PRELIMINARY

**Table 4-1: 3D MagIC Pin Assignments**

MLF Pin#	Die Pad#	Pin Name	Description
1	1	MOSI	SPI interface – Master Output, Slave Input Serial Data
2	2	NC	Do not connect
3	3	SSN	SPI interface – Active low to select port
4	4	AV <sub>DD</sub>	Supply voltage for analog section of ASIC
5	5	AV <sub>SS</sub>	Ground pin for analog section of ASIC
6	6	Z <sub>DRVP</sub>	Z sensor drive output
7	7	Z <sub>INP</sub>	Z sensor measurement input
8	8	Z <sub>INN</sub>	Z sensor measurement input
9	9	Z <sub>DRVN</sub>	Z sensor drive output
10	10	Y <sub>DRVP</sub>	Y sensor drive output
11	11	Y <sub>INP</sub>	Y sensor measurement input
12	12	MODE	Mode Select: tie to DV <sub>SS</sub> for Standard, DV <sub>DD</sub> for Legacy
13	13	Y <sub>INN</sub>	Y sensor measurement input
14	14	Y <sub>DRVN</sub>	Y sensor drive output
15	15	X <sub>DRVP</sub>	X sensor drive output
16	16	X <sub>INP</sub>	X sensor measurement input
17	17	X <sub>INN</sub>	X sensor measurement input
18	18	X <sub>DRVN</sub>	X sensor drive output
19	19	DV <sub>SS</sub>	Ground pin for digital section of ASIC
--	20	NC	Do not connect
20	21	NC	Do not connect
21	22	NC	Do not connect
22	23	CLEAR	Clear Command Register
23	24	DRDY	Data ready command
24	25	COMP	Comparator output (used for debugging and generally not connected)
25	26	R <sub>EXT</sub>	External timing resistor for high speed clock.
26	27	DV <sub>DD</sub>	Supply voltage for digital section of ASIC.
27	28	SCLK	SPI interface - Serial clock input
28	29	MISO	SPI interface – Master Input, Slave Output



---

## 5 SPI Interface

Data flow to and from the 3D MagIC is through a synchronous serial interface that adheres to the SPI bus protocol. The user also may implement hardware handshaking, but this is optional. This section reviews the SPI interface and hardware handshaking.

---

### 5.1 SPI Pins

---

#### 5.1.1 SCLK (Serial Clock Input)

An SPI input is used to synchronize the data sent in and out through the MISO and MOSI pins. SCLK is generated by the customer-supplied master device and should be 1 MHz or less. One byte of data is exchanged over eight clock cycles. Data is captured by the master device on the rising edge of SCLK. Data is shifted out and presented to the 3D MagIC on the MOSI pin on the falling edge of SCLK.

---

#### 5.1.2 SSN (Slave Select)

This signal sets the 3D MagIC as the operating slave device on the SPI bus. The SSN pin must be LOW prior to data transfer in either direction, and must stay LOW during the entire transfer. The SPI bus can be freed up (SSN pin set HIGH) for communication with another slave device while the 3D MagIC is taking a measurement or idle, but after all communication between the 3D MagIC and master device is finished. If the 3D MagIC is the only device on the SPI bus, this pin may be permanently grounded.

---

#### 5.1.3 MISO (Serial Out)

An SPI output that sends data from the 3D MagIC to the master device. Data is transferred most significant bit first and is captured by the master device on the rising edge of SCLK. The MISO pin is placed in a high impedance state if the 3D MagIC is not selected (i.e. if SSN=1).

---

#### 5.1.4 MOSI (Serial In)

An SPI input that provides data from the master device to the 3D MagIC. Data is transferred most significant bit first. Data must be presented at least 50 ns before the rising edge of SCLK, and remain valid for 50 ns after the edge. New data may be presented to the MOSI pin on the falling edge of SCLK.

---

## 5.2 Hardware Handshaking Pins

---

### 5.2.1 DRDY (Data Ready)

It is recommended the DRDY pin be used to ensure data is read out of the 3D MagIC only when it is available. After the Initiate Sensor Measurement command has been sent, the DRDY pin will go HIGH when the measurement is complete. This signals the host system that data is ready to be read. The DRDY pin should be set LOW sometime prior to initiating another measurement. This is done by clearing the Command Register by either of the following actions:

- externally, by toggling the CLEAR pin, or
- internally, after reading or writing to the Clock Set Register.

---

*Note: If a new command sequence is started before the previous measurement has completed (before DRDY goes HIGH), the previous command will be overwritten. This will also stop the measurement cycle. If you try to send a new command during the readout phase, after DRDY goes HIGH, the command will be ignored until all 16 bits have been clocked out or the CLEAR pin is set HIGH (then LOW again).*

---

### 5.2.2 CLEAR (Clear Command Register)

To initiate a clear command, the CLEAR pin must be toggled LOW-HIGH-LOW. CLEAR is usually LOW. A CLEAR will clear the Command Register and reset the DRDY pin to LOW. CLEAR can be used to stop any sensor measurement in progress. CLEAR has no effect on the SPI register state.

---

*Note: The CLEAR pin is similar to the RESET pin on PNI's legacy ASIC. However reading or writing to the Clock Set Register also will clear the Command Register. Consequently, it is not necessary to utilize the CLEAR pin if the host system will read or write to the Clock Set Register to clear the Command Register.*

---

---

## 5.3 SPI Interface Operation

When implementing an SPI port, whether a dedicated hardware peripheral port or a software-implemented port using general purpose I/O (also known as *Bit-Banging*), the timing parameters (given in Figure 5-1, Figure 5-2, and Figure 5-3) must be met to ensure reliable communications. When SCLK is LOW, the data is in transition. The clock set-up and hold times,  $t_{DBSH}$  and  $t_{DASH}$  must be greater than 50 ns. The clock phase used with the 3D MagIC is zero (CPOL=0). Data is present on MISO or should be presented on MOSI before the first low to high clock transition.

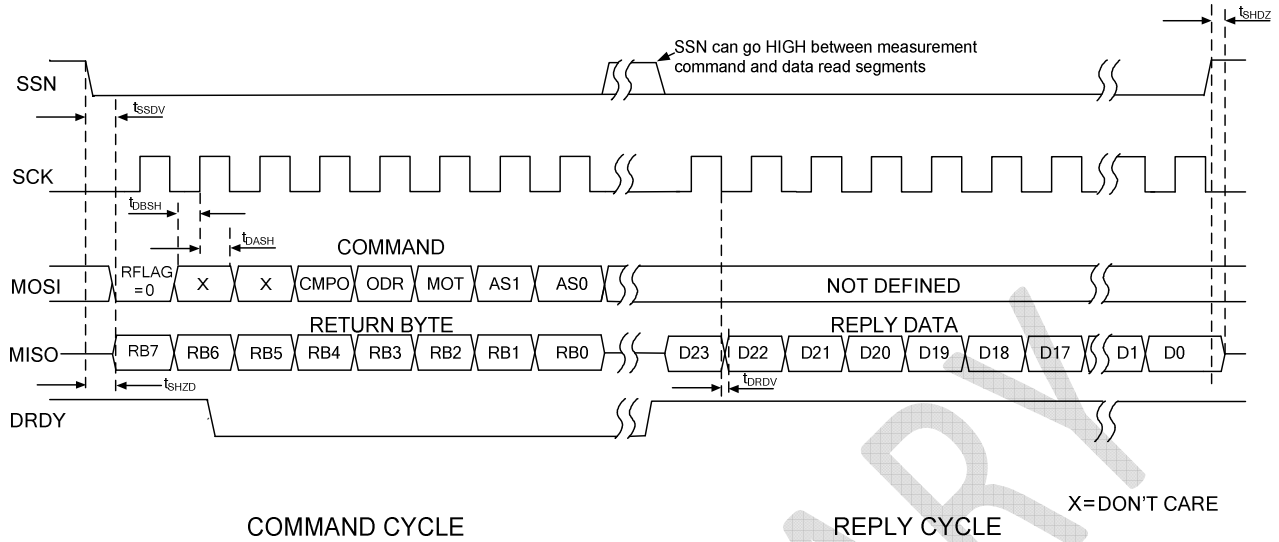

Figure 5-1: SPI Measure/Read Data Timing Diagram – Standard Mode

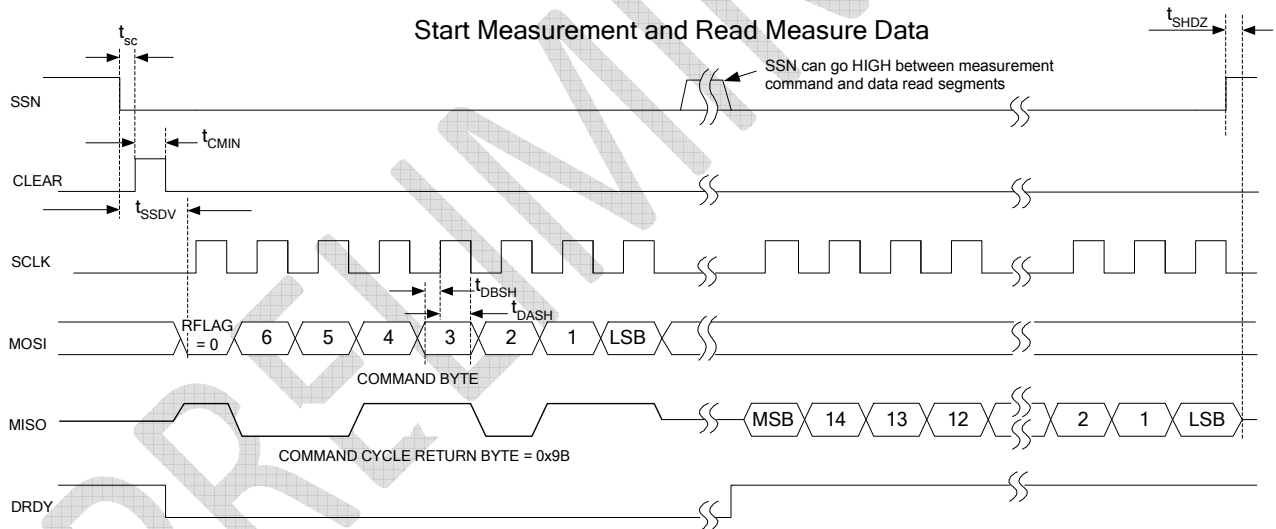

Figure 5-2: SPI Measure/Read Data Timing Diagram – Legacy Mode

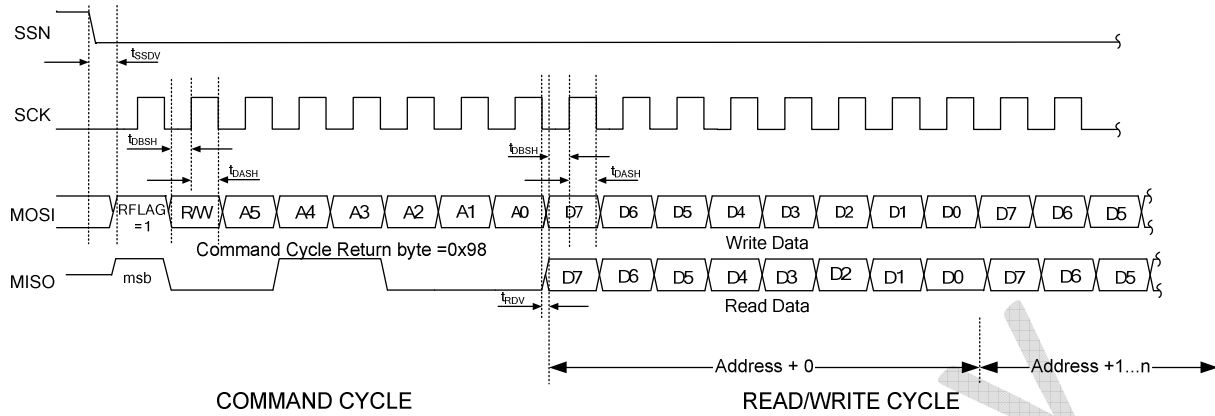

Figure 5-3: SPI Read/Write Data Timing

Table 5-1: Timing Specifications

SYMBOL	DESCRIPTION	MIN	TYP	MAX	UNITS
$t_{SC}$	Time from SSN to CLEAR	10			ns
$t_{CMIN}$	CLEAR duration	100			ns
$t_{SSDV}$	Time from SSN to Command Byte on MOSI	1			us
$t_{DBSH}$	Time to setup data before active edge	50			ns
$t_{DASH}$	Time to setup data after active edge	50			ns
$t_{SHDZ}$	Time from SSN to data tri-state time			100	ns

Note that an SPI port can be implemented using different clock polarity options. The clock polarity used with the 3D MagIC should be low (CPOL=0). Generally data is considered valid while SCLK is high, and when SCLK is low, data is in transition.

As previously noted, keeping the SSN pin LOW dedicates the master device to the 3D MagIC. If the user has no other slave devices, the SSN pin can be permanently grounded. Conversely, if the user has multiple slave devices, then the SPI bus can be freed up for other devices by bringing the SSN pin HIGH. The SSN pin can be brought HIGH either:

- after sending the command word on the MOSI pin but before reading the measurement data on the MISO pin, and/or
- after receiving the measurement data on the MISO pin.

## 6 Operation – Standard Mode

The 3D MagIC operates in Standard Mode when pin #12 is held LOW (grounded to DV<sub>SS</sub>). This section discusses how to operate the 3D MagIC in Standard Mode. For a description of operation in Legacy Mode, see Section 7.

### 6.1 Command Register

The Command Register can be used either to initiate a sensor measurement or to read/write to the Cycle Count Registers. It consists of one byte. Bit 7 is the Register Access Flag (RFLAG), and this controls whether a sensor measurement will be initiated or a read/write to a register will be initiated. The setting of bits 0-6 depends on how RFLAG is set.

#### 6.1.1 Initiate Sensor Measurement

The Command Byte is defined as follows:

7	6	5	4	3	2	1	0
RFLAG=0	0	0	CMPO	ODIR	MOT	AS1	AS0

##### **CMPO: Comparator Output**

When set HIGH, this enables comparator output on the COMP pin.

##### **ODIR: Oscillator Direction**

Determines the magnetic oscillator direction if MOT is set HIGH. If MOT is set LOW, ODIR has no effect. Used for debug only.

##### **MOT: Magnetic Oscillator Test**

When set HIGH, causes the sensor oscillator selected by AS0 and AS1 (in the direction selected by ODIR) to run continuously. The COMP pin output is always enabled when MOT is HIGH. When the MOT bit is set HIGH, the data read segment is not supported and a new command can be received immediately. MOT mode can be exited by sending a measurement command, by setting CLEAR to HIGH, or by receiving a NO OP command (AS0=AS1=0).

##### **AS0-AS1: Axis Select**

Determines the sensor to be measured.

	AS1	AS0
No Op: see note	0	0
Channel 1 (X axis)	0	1
Channel 2 (Y axis)	1	0
Channel 3 (Z axis)	1	1

Note: If no measurement is executed, then the previous measurement will be read back if data is clocked out.

---

## 6.1.2 Read/Write to a Cycle Count Register

The Command Byte is defined as follows:

7	6	5	4	3	2	1	0
RFLAG=1	R/W	0	0	ADR3	ADR2	ADR1	ADR0

### R/W: Read/Write

HIGH signifies a Read operation from the addressed register. LOW signifies a Write operation to the addressed register.

### ADR0 – ADR3: Register Address Bits

Establishes which register will be written to or read from. When adjacent registers are to be addressed, which is typically is the case, it is not necessary to reinitiate the command sequence as the 3D MagIC automatically will read/write to the next adjacent register. (See the example in the following section.)

---

## 6.2 Cycle Count Registers

The Cycle Count Registers establish the number of sensor oscillations cycles that will be counted for each sensor during a measurement sequence. Varying the cycle count allows the user to increase measurement resolution (higher cycle counts) or increase the data rate (lower cycle counts). Each sensor is represented by two registers, with addresses defined as follows:

**Table 6-1: Cycle Count Registers**

REGISTER NAME	DESCRIPTION	REGISTER ADDRESS
CCPX1	X Axis Cycle Count Value - MSB	3 <sub>H</sub>
CCPX0	X Axis Cycle Count Value - LSB	4 <sub>H</sub>
CCPY1	Y Axis Cycle Count Value - MSB	5 <sub>H</sub>
CCPY0	Y Axis Cycle Count Value - LSB	6 <sub>H</sub>
CCPZ1	Z Axis Cycle Count Value - MSB	7 <sub>H</sub>
CCPZ0	Z Axis Cycle Count Value - LSB	8 <sub>H</sub>

An example of a command sequence to set the cycle count value to 100<sub>D</sub> (64<sub>H</sub>) for all 3 axes is as follows. Note that since the registers are adjacent, it is not necessary to send multiple Command Register commands, as the 3D MagIC will automatically read/write to the next adjacent register.

1. Set SSN to LOW
2. Send 0x83<sub>H</sub> (this is the Command Register byte & addresses the MSB for the X axis)
3. Send 0 (this is the MSB for the X axis)
4. Send 0x64<sub>H</sub> (this is the LSB for the X axis)
5. Send 0 (this is the MSB for the Y axis)
6. Send 0x64<sub>H</sub> (this is the LSB for the Y axis)
7. Send 0 (this is the MSB for the Z axis)
8. Send 0x64<sub>H</sub> (this is the LSB for the Z axis)
9. Set SSN to High

The default for all three axes is a cycle count value of 512<sub>D</sub> (LSB = 0<sub>H</sub>, MSB = 20<sub>H</sub>).

## 6.3 Making a Measurement

The steps to make a sensor measurement are given below, and the sequence and timing are given in Figure 5-1 and Figure 5-3. In general, the user sends an Initiate Sensor Measurement command to the 3D MagIC through the SPI interface specifying the sensor to be measured. The Cycle Count Registers should already be set prior to sending this command (or the default values will be used). In Standard Mode, the 3D MagIC returns the result of a complete forward- reverse measurement of the sensor in a 24 bit 2's complement

format (range: -8388608 to 8388607). Note that only one sensor can be measured at a time.

1. SSN pin is set LOW. This enables communication with the master device.
2. The Initiate Sensor Measurement byte is clocked into the 3D MagIC on the MOSI pin. Simultaneously, the 3D MagIC will present a fixed 0x9A on the MISO pin. Once the 8 bits have clocked in, the 3D MagIC will execute the command (i.e. take a measurement).
3. The SSN input may be returned HIGH at this point to free up host communication with another device if desired. This will not affect the measurement process.
4. A measurement is taken, which consists of forward biasing the sensor and measuring how long it takes to accomplish the pre-defined number of cycle counts; then reverse biasing the sensor and measuring again; and then taking the difference in time between the two directions and presenting this value.
5. At the end of the measurement, the DRDY pin is set HIGH, indicating data is ready, and the 3D MagIC is placed in Idle Mode.
6. The SSN input should be set LOW, if it is not already, to read the data.
7. The data is clocked out on the MISO pin with the next 24 clock cycles.
8. If another measurement is to be made immediately, the SSN pin can remain low and the process repeated, starting at line #2 above. Otherwise, it generally is recommended to set the SSN pin HIGH to release the SPI serial bus.



## 7 Operation – Legacy Mode

The 3D MagIC will operate in Legacy Mode when pin #12 is held HIGH (connected to DV<sub>DD</sub>). The intent of Legacy Mode is to enable the user to easily substitute PNI's 3D MagIC for PNI's legacy 11096 ASIC (p/n 12576). This section discusses how to operate the 3D MagIC in Legacy Mode. For a description of operation in Standard Mode, see Section 6.

### 7.1 Command Register

The Command Register can be used either to initiate a sensor measurement or set-up a read/write to the Clock Set Register. It consists of one byte. Bit 7 is the Register Access Flag (RFLAG), and this controls whether a sensor measurement will be initiated or a read/write to the Clock Set Register will be initiated. The setting of bits 0-6 depends on how RFLAG is set.

#### 7.1.1 Initiate Sensor Measurement

The Command Register is defined as follows:

7	6	5	4	3	2	1	0
RFLAG=0	PS2	PS1	PS0	ODIR	MOT	AS1	AS0

#### PS0-PS2: Period Select

Selects the number of sensor circuit oscillation cycles (periods) to be counted while simultaneously using the internal fixed reference clock to measure the time to obtain this count.

Period Select Value	Cycle Counts	PS2	PS1	PS0
0	32	0	0	0
1	64	0	0	1
2	128	0	1	0
3	256	0	1	1
4	512	1	0	0
5	1024	1	0	1
6	2048	1	1	0
7	4096	1	1	1

**ODIR: Oscillator Direction**

Determines the magnetic oscillator direction if MOT is set HIGH. If MOT is set LOW, ODIR has no effect. Used for debug only.

**MOT: Magnetic Oscillator Test**

When set HIGH, causes the sensor oscillator selected by AS0 and AS1 (in the direction selected by ODIR) to run continuously. The COMP pin output is always enabled when MOT is HIGH. When the MOT bit is set HIGH, the data read segment is not supported and a new command can be received immediately. MOT mode can be exited by sending a measurement command, by setting CLEAR to HIGH, or by receiving a NO OP command (AS0=AS1=0).

**AS0-AS1: Axis Select**

Determines the sensor to be measured.

	AS1	AS0
No Op: see note	0	0
Channel 1 (X axis)	0	1
Channel 2 (Y axis)	1	0
Channel 3 (Z axis)	1	1

Note: No measurement will be executed, and the previous measurement will be read back if data is clocked out.

---

## 7.1.2 Read/Write to Clock Set Register

The Command Register is defined as follows:

7	6	5	4	3	2	1	0
RFLAG=1	R/W	0	0	0	0	0	0

Bits 0-5 must be set LOW when RFLAG = 1.

**R/W: Read/Write**

When HIGH signifies a Read operation from the Clock Set Register. When LOW signifies a Write operation to the Clock Set Register.

## 7.2 Clock Set Register

*Note: If a user incorporates the 3D MagIC in a legacy 11096 ASIC system and uses the same Period Select value, and leaves the Counter Divide and Period Divide values at their default values, then the 3D MagIC will provide approximately the same resolution as PNI's legacy ASIC at the same data rate.*

The Clock Set Register commands allow the user to operate the 3D MagIC in Legacy Mode similar to PNI's legacy ASIC, but derive some of the benefits available with the 3D MagIC. Specifically, due to the higher clock speed (30 MHz vs 2 MHz) of the MagIC, it is capable of providing either higher resolution for the same acquisition time (data rate) or comparable resolution for a shorter acquisition time. This is done by varying the Clock Divide and Period Divide values in the Clock Set Register. And, since power consumption is directly correlated to acquisition time, this means an existing system can run with lower power consumption while retaining comparable resolution.

Specifically, setting the Clock Divide to 1 and making no other changes provides a theoretical increase in resolution of 16x, without altering the data rate. Alternatively, setting the Clock Divide to 1 and setting the Period Divide to 16 provides nominally the same resolution, but at 1/16<sup>th</sup> the acquisition time, which is useful for high speed applications and/or applications that are sensitive to power consumption.

The Command Register is defined as follows:

7	6	5	4	3	2	1	0
0	PCS2	PCS1	PCS0	0	CD2	CD1	CD0

### 7.2.1 Clock Divide

The 3D MagIC's high-speed clock runs at nominally 32 MHz, but PNI's legacy ASIC runs at nominally 2 MHz. Consequently, when the 3d MagIC is in default Legacy Mode, the clock speed is divided by 16, to bring it down to an effective clock speed of 2 MHz (same as the legacy 11096 ASIC.) The Clock Divide bits allow the user to alter the divisor for the high speed clock. Setting the Clock Divide bits all to "0" results in high speed clock operating at its full speed. Below is a table that summarized the clock divide values for given Clock Divide bits.

Clock Divide Value	CD2	CD1	CD0
1	0	0	0
2	0	0	1
4	0	1	0
8	0	1	1
16	1	0	0
16	1	0	1
16	1	1	0
16	1	1	1

## 7.2.2 Period Divide

The Period Divide divides the Period Select value by the Period Divide value. The default is 1, which leaves the number of cycle counts to be counted unchanged.

PCS Value	PCS2	PCS1	PCS0
1	0	0	0
2	0	0	1
4	0	1	0
8	0	1	1
16	1	0	0
16	1	0	1
16	1	1	0
16	1	1	1

The Period Divide can be used to run the 3D MagIC at fewer cycles than allowed by the Period Select. For example, a Period Select value of 0 dictates that 32 cycles will be counted. By setting the Period Divide value to 16, the number of cycles is reduced to 2 cycles, which represents the fewest number of cycles possible with the 3D MagIC. (Fundamental resolution also will have decreased by a factor of 16 by doing this.) This can be very useful for high-speed applications, such as video gaming, that require frequent data updates.

## 7.3 Making a Measurement

The steps to make a sensor measurement are given below, and the sequence and timing are given in Figure 5-3 and Figure 5-3. In general, the user sends an Initiate Sensor Measurement command to the 3D MagIC through the SPI interface specifying the sensor to be measured and the Period Select. If the user wants to alter the Counter Divide or Period Divide, they should do this separately by sending a command to the Clock Set Register. In Legacy Mode, the 3D MagIC returns the result of a complete forward- reverse measurement of the sensor in a 16 bit 2's complement format (range: -32768 to 32767). Note that only one sensor can be measured at a time, and that .

1. SSN pin is set LOW. (This enables communication with the master device.)
2. CLEAR pin is set HIGH, then LOW. This is not required, but is optional to maintain compatibility with the legacy 11096 ASIC.
3. A command byte is clocked into the 3D MagIC on the MOSI pin. Simultaneously, the 3D MagIC will present a fixed 0x9B on the MISO pin. Once the 8 bits have clocked in, the 3D MagIC will execute the command (i.e. take a measurement).
4. The SSN input may be returned HIGH at this point to free up host communication with another device if desired. This will not affect the measurement process.
5. A measurement is taken, which consists of forward biasing the sensor and making a period count; then reverse biasing the sensor and counting again; and then taking the difference between the two directions and presenting this value.
6. At the end of the measurement, the DRDY pin is set HIGH, indicating data is ready, and the 3D MagIC is placed in Idle Mode.
7. The SSN input should be set LOW, if it is not already, to read the data.
8. The data is clocked out on the MISO pin with the next 16 clock cycles.
9. If another measurement is to be made immediately, the SSN pin can remain low and the process repeated. Otherwise, it generally is recommended to set the SSN pin HIGH to release the SPI serial bus.