

## Features and Benefits

- Programmable high speed current sensor IC
- Wideband: DC to 90kHz
- Short response time
- Triaxis® hall technology
- Programmable linear transfer characteristic
- Selectable
  - analog ratiometric output
  - PWM output with 12 bit resolution
- Thermometer output
- 17 bit ID Number
- SOIC8 package RoHS compliant
- Lead free component, suitable for lead free soldering profile 260 °C (target), MSL3

## Application Examples

- DC/AC (inverter) converter
- DC/DC switched mode power supply
- Battery Management
- Smart fuse (over-current detection)
- BLDC motor (phase current)
- AC/DC Converters

## Ordering Information

Product Code	Temperature Code	Package Code	Ordering Option Code	Packing form Code	Sensitivity Range (Typ.)
MLX91206	L (-40 °C to 150 °C)	DC (SOIC)	CAL-001	TU (Tube) / RE (Reel)	460-700mV/mT (580mV/mT)
MLX91206	L (-40 °C to 150 °C)	DC (SOIC)	CAL-002		300-470mV/mT (380mV/mT)
MLX91206	L (-40 °C to 150 °C)	DC (SOIC)	CAL-003		200-310mV/mT (250mV/mT)
MLX91206	L (-40 °C to 150 °C)	DC (SOIC)	CAH-001		210-330mV/mT (270mV/mT)
MLX91206	L (-40 °C to 150 °C)	DC (SOIC)	CAH-002		130-220mV/mT (170mV/mT)
MLX91206	L (-40 °C to 150 °C)	DC (SOIC)	CAH-003		80-140mV/mT (110mV/mT)
MLX91206	L (-40 °C to 150 °C)	DC (SOIC)	CAH-004		60-110mV/mT (77.5mV/mT)
MLX91206	L (-40 °C to 150 °C)	DC (SOIC)	CAH-104 <sup>(1)</sup>		0.5-5%DC/mT

(1) The MLX91206 sensor is in PWM mode by default for this version

Ordering example: MLX91206LDC-CAL-001-RE

## 1 Functional Diagram

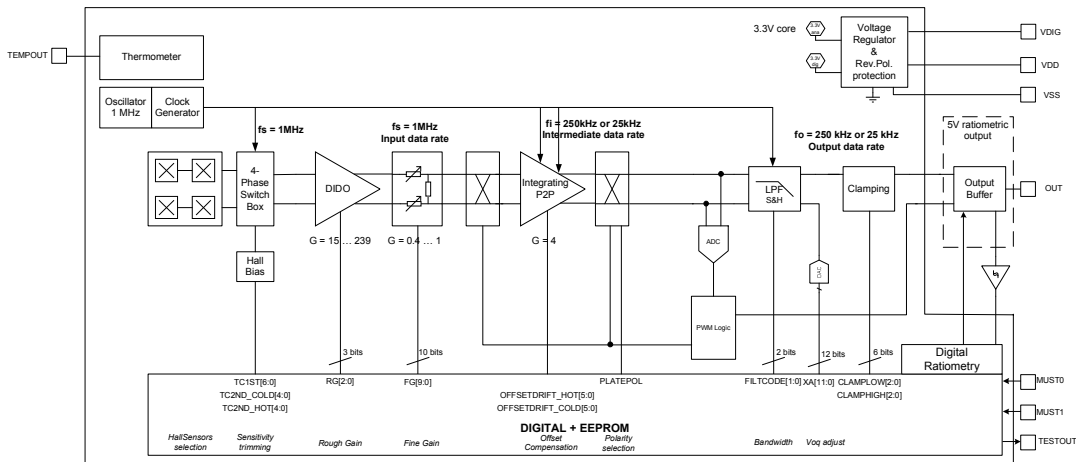

Figure 1: Block diagram

## 2 General Description

The MLX91206 is a monolithic sensor IC featuring the Tria<sup>®</sup>is<sup>®</sup> Hall technology. Conventional planar Hall technology is only sensitive to the flux density applied orthogonally to the IC surface. The Tria<sup>®</sup>is<sup>®</sup> Hall sensor is sensitive to the flux density applied parallel to the IC surface. This is obtained through an Integrated Magneto-Concentrator (IMC<sup>®</sup>) which is deposited on the CMOS die (as an additional back-end step). The IMC technology is automotive qualified.

The product is a single chip Hall sensor which provides an output signal which is proportional to the flux density applied horizontally and is therefore suitable for current measurement. It is ideally used as an open loop current sensor for PCB mounting. (see figure 2). It features small size application design and a simple construction for various current ranges.

The transfer characteristic of the MLX91206 is programmable (offset, gain, clamping levels, diagnostic functions...). The output is selectable between analog and PWM. The linear analog output is used for application where a very fast response (<10  $\mu$ sec) is required, whereas the PWM output is used for application where low speed but high output signal robustness is required.

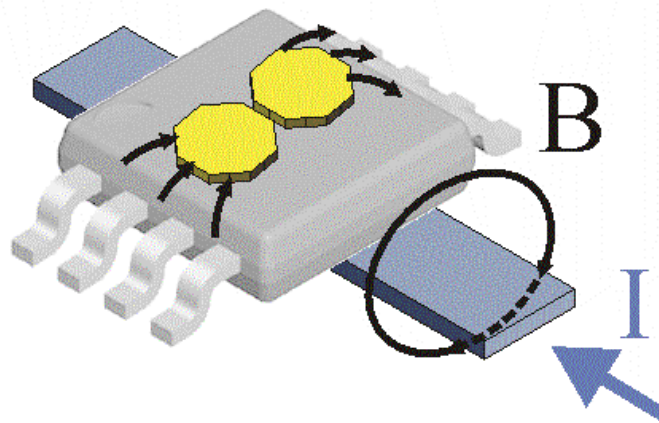

Figure 2: Typical application of MLX91206



### Table of Contents

1 Functional Diagram.....	1
2 General Description.....	2
3 Glossary of Terms.....	4
4 Absolute Maximum Ratings.....	4
5 Pin Definitions and Descriptions.....	4
6 General Electrical Specifications.....	5
7 Magnetic specification.....	6
7.1 25 mT version (marking xxH).....	6
7.2 10 mT version (marking xxL).....	6
8 Analog output specification.....	7
8.1 Timing specification.....	7
8.2 Accuracy specification.....	7
8.3 Remarks to the achievable accuracy.....	7
9 PWM output specification.....	8
9.1 Timing specification for the PWM output.....	8
9.2 Magnetic specification for the PWM output.....	9
9.3 Accuracy specification transfer characteristic PWM.....	9
10 Thermometer output specification.....	9
11 Programmable items.....	10
11.1 Parameter table.....	10
11.2 Output mode configuration (DSPMODE, OUTMODE).....	11
11.3 Output impedance mode (DIAGINFAULT).....	11
11.4 Reference edge (REFEDGE) – only in PWM mode.....	11
11.5 PWM/switch mode (SWITCH).....	11
11.6 Platepol (PLATEPOL).....	12
11.7 Sensitivity programming (ROUGHGAIN, FINEGAIN).....	12
11.8 Offset / output quiescent voltage programming (XA, YA).....	13
11.9 Clamping level programming (CLAMPLOW, CLAMPHIGH).....	13
11.10 Bandwidth and filter programming (FILTCODE).....	14
11.11 Power limitation / PWM rise and fall time (OUTSLOPE).....	15
11.12 PWM Mode duty cycle definition (DCDEF).....	16
11.13 Output ratiometry (RATIODIS).....	16
11.14 Sensitivity and temperature drift programming (TC1ST, TC2ND_COLD, TC2ND_HOT).....	16
11.15 Offset temperature drift programming (OFFDRIFT_COLD, OFFDRIFT_HOT).....	16
11.16 Product Identification (MLXID, CSTID).....	17
12 Application information.....	18
12.1 Low current measurement up to $\pm 2$ A.....	18
12.2 Medium current up to $\pm 30$ A.....	18
12.3 High current measurement up to $\pm 600$ A.....	18
13 Recommended Application Diagrams.....	19
13.1 Resistor and capacitor values.....	19
13.2 Fast analog application, pull-down resistor for diagnostic low.....	19
13.3 Fast analog application, pull-up resistor for diagnostic high.....	20
13.4 Robust PWM application, (pull-up load only).....	20
14 Standard information regarding manufacturability of Melexis products with different soldering processes.....	<b>Error! Bookmark not defined.</b>
15 ESD Precautions.....	21
16 Package Information.....	22
16.1 SOIC8 Package dimensions.....	22
16.2 SOIC8 Pinout and Marking.....	22
16.3 SOIC8 Hall plate position.....	23
16.4 IMC Position and sensors active measurement direction.....	23
17 Related documents and tools.....	24
17.1 Related documents.....	24
17.2 Related software.....	24
17.3 Related hardware.....	24
18 Disclaimer.....	25



### 3 Glossary of Terms

Tesla	Units for the magnetic flux density, 1 mT = 10 Gauss
TC	Temperature Coefficient in ppm/deg C
NC	Not Connected
PWM	Pulse Width Modulation
%DC	Duty Cycle of the output signal i.e. $T_{ON} / (T_{ON} + T_{OFF})$
ADC	Analog to Digital Converter
DAC	Digital to Analog Converter
LSB	Least Significant Bit
MSB	Most Significant Bit
DNL	Differential Non Linearity
INL	Integral Non Linearity
IMC	Integrated Magneto Concentrator (IMC®)
PTC	Programming Through Connector

### 4 Absolute Maximum Ratings

Parameter	Symbol	Value	Units
Positive Supply Voltage (overvoltage)	Vdd	+20	V
Reverse Supply Voltage Protection		-10	V
Positive Output Voltage		+10 +14 (200 s max, T <sub>A</sub> = +25 °C)	V
Output Current	I <sub>out</sub>	±300	mA
Reverse Output Voltage		-0.3	V
Reverse Output Current		-50	mA
Operating Ambient Temperature Range	T <sub>A</sub>	-40 to +150	°C
Storage Temperature Range	T <sub>s</sub>	-55 to +165	°C
Magnetic Flux Density		±0.2	T

Table 1: Absolute maximum ratings

Exceeding the absolute maximum ratings may cause permanent damage. Exposure to absolute maximum rated conditions for extended periods may affect device reliability.

### 5 Pin Definitions and Descriptions

Pin No	Name	Type	Function
1	VDD	Supply	Supply Voltage
2	VSS	Ground	Supply Voltage
3	VDIG	Supply	Digital supply voltage, 3.3 V, internal regulated
4	MUST1	Digital	Test and Factory calibration
5	OUT / PWM	Analog/Digital	Current sensor output
6	TESTOUT	Digital	Test and Factory calibration
7	MUST0	Digital	Test and Factory calibration
8	TEMPOUT	Analog	Temperature Sensor Output

Table 2: Pin definition and description

It is recommended to connect the unused pins to the Ground (see section 16) for optimal EMC results.

### 6 General Electrical Specifications

Operating Parameters :  $T_A = -40$  to  $125^{\circ}\text{C}$ ,  $V_{dd} = 4.5$  V to  $5.5$  V,  $I_{out} = -2$  mA to  $+2$  mA, recommended application diagram in section 16, unless otherwise specified. All mentioned component values can have a  $\pm 20\%$  tolerance

Parameter	Symbol	Test Conditions	Min	Typ	Max	Units
Nominal Supply Voltage	Vdd		4.5	5	5.5	V
Supply Current	Idd	W/o output load & $T_A = -40$ to $150^{\circ}\text{C}$ - ROUGHGAIN $\leq 3$ - ROUGHGAIN $> 3$		7 9	10 12	mA mA
Output Current	Iout		-2		2	mA
Output Resistance		$V_{out} = 50\% V_{dd}$ , $R_L = 5\text{k}\Omega$		1	5	$\Omega$
Output Capacitive Load	Cload	Analog Mode	5	10	50	nF
		PWM Mode	0	10	50	nF
Output Short Circuit Current	Ishort	Output shorted to Vdd- Permanent	Not Destroyed			
		Output shorted to Vss - Permanent	Not Destroyed			
Leakage current	Ileak	High impedance mode <sup>(2)</sup>			5	$\mu\text{A}$
Output Voltage Swing (Linear Range)	$V_{out\_pd}$	pull down $\geq 10\text{k}\Omega$	5		95	%Vdd
	$V_{out\_pu}$	pull up $\geq 10\text{k}\Omega$	5		95	%Vdd
High-impedance mode levels <sup>(2)</sup>	$V_{out\_HiZ\_pu}$	pull-up $R_L \leq 30\text{k}\Omega$	97			%Vdd
	$V_{out\_HiZ\_pd}$	pull-down $R_L \leq 30\text{k}\Omega$			3	%Vdd
BrokenVss Output Levels <sup>(2)</sup>	OUT with pull-down $R_L \leq 10\text{k}\Omega$ <sup>(3)</sup>				3	%Vdd
	OUT with pull-up $R_L \leq 30\text{k}\Omega$ <sup>(3)</sup>		97			%Vdd
BrokenVdd Output Levels <sup>(2)</sup>	OUT with pull-down $R_L \leq 30\text{k}\Omega$ <sup>(3)</sup>				3	%Vdd
	OUT with pull-up $R_L \leq 30\text{k}\Omega$ <sup>(3)</sup>		97			%Vdd
Under-voltage detection <sup>(2) (4)</sup>	$V_{dd\_uvd}$	Detected Voltage (Low to High)	3.15	3.3	3.45	V
	$V_{dd\_uvh}$	Hysteresis	0.25	0.3	0.4	V
Over-voltage detection mode 1 <sup>(2) (4)</sup>	$V_{dd\_ovd1}$	Detected Voltage (Low to High)	7.9		9.5	V
	$V_{dd\_ovh1}$	Hysteresis	0.8		1.6	V
Over-voltage detection mode 2 <sup>(2) (4)</sup>	$V_{dd\_ovd2}$	Detected Voltage (Low to High)	6.7		7.6	V
	$V_{dd\_ovh2}$	Hysteresis	0.05		0.5	V
Clamped Output Level	Clamp_lo	Trimming Range	5 <sup>(1)</sup>		10	%Vdd
	Clamp_hi	Trimming Range	90		95 <sup>(1)</sup>	%Vdd

Table 3: General electrical parameter

- (1) Factory programmed clamping level
- (2) Refer to chapter **Self-diagnostic, table 21**.
- (3) Valid for TEMPOUT with pull-up (min.  $30\text{k}\Omega$ ), pull-down (min.  $30\text{k}\Omega$ ) or not connected
- (4) According to the figure below

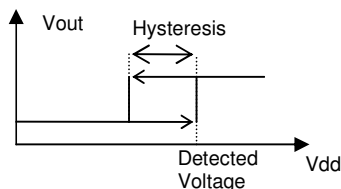

Figure "Detected voltage and hysteresis definitions"



## 7 Magnetic specification

### 7.1 25 mT version (marking xxH)

Operating Parameters  $T_A = -40$  to  $125\text{degC}$ ,  $V_{dd} = 4.5$  V to  $5.5$  V, unless otherwise specified.

Parameter	Symbol	Test Conditions	Min	Typ	Max	Units
Nominal Field Range	Bnom		-20		+20	mT
Operational Field Range <sup>(1)</sup>	Bop		-25		+25	mT
Linearity Error	NL	Nominal Field Range (25°C)	-0.5		+0.5	%FS
		Operational Field Range (25°C)	-0.75		+0.75	%FS
Hysteresis, remanent Field	Br	B = Bop	-25		+25	uT
Programmable Sensitivity <sup>(2)</sup>	S	B = Bop , Analog Mode	80		330	mV/mT
Sensitivity programming Resolution	Sres	B = Bop		0.1		%

Table 4: Magnetic specification 25mT version (high-field version)

- (1) Above 25 mT, the IMC starts saturating yielding to an increase of the linearity error.  
 (2) The specified programmable sensitivity range is covered by 4 different versions (option codes)

Option code (25mT)	Programmed Sensitivity	Sensitivity Range
CAH-001	270mV/mT	210..330mV/mT
CAH-002	170mV/mT	130..220mV/mT
CAH-003	110mV/mT	80..140mV/mT
CAH-004	77.5mV/mT	60..110mV/mT

### 7.2 10 mT version (marking xxL)

Operating Parameters  $T_A = -40$  to  $125\text{degC}$ ,  $V_{dd} = 4.5$  V to  $5.5$  V (unless otherwise specified)

Parameter	Symbol	Test Conditions	Min	Typ	Max	Units
Nominal Field Range	Bnom		-7.5		+7.5	mT
Operational Field Range <sup>(3)</sup>	Bop		-10		+10	mT <sup>(2)</sup>
Linearity Error	NL	Nominal Field Range (25°C)	-0.5		+0.5	%FS
		Operational Field Range (25°C)	-0.75		+0.75	%FS
Hysteresis, remanent Field	Br	B = Bop	-10		+10	uT
Programmable Sensitivity <sup>(4)</sup>	S	B = Bop , Analog Mode	200		700	mV/mT
Sensitivity programming Resolution	Sres	B = Bop		0.1		%

Table 5: Magnetic specification 10mT version (low-field version)

- (3) Above 10 mT, the IMC starts saturating yielding to an increase of the linearity error.  
 (4) The specified programmable sensitivity range is covered by 3 different versions (option codes)

Option code (10mT)	Programmed Sensitivity	Sensitivity Range
CAL-001	580mV/mT	460-700mV/mT
CAL-002	380mV/mT	300-470mV/mT
CAL-003	250mV/mT	200-310mV/mT



## 8 Analog output specification

### 8.1 Timing specification

Operating Parameters  $T_A = -40$  to  $125\text{degC}$ ,  $V_{dd} = 4.5$  V to  $5.5$  V (unless otherwise specified)

Parameter	Symbol	Test Conditions	Min	Typ	Max	Units
Step Response Time	Tresp	$V_{oq} \pm 2$ V		8	10	$\mu\text{s}$
Bandwidth	BW	Full Range	50	70	90	kHz
Power on Delay	$T_{POD}$	Vout =100% of FS (BW = 100 Hz) (BW = 1000 Hz) (BW = 10 kHz) (BW = 100 kHz – No filter)			100	ms
					10	ms
					5	ms
					5	ms
Ratiometry Cut-off Frequency	Fratio			250		Hz

Table 6: Timing specification high speed analog output

### 8.2 Accuracy specification

Operating Parameters  $T_A = -40$  to  $125\text{degC}$ ,  $V_{dd} = 4.5$  V to  $5.5$  V (unless otherwise specified)

Parameter	Symbol	Test Conditions	Min	Typ	Max	Units
Thermal Offset Drift	$\Delta^T V_{oq}$		-0.4		+0.4	%Vdd
Thermal Sensitivity Drift	TC		-150		+150	ppm/°C
RMS Output noise	$N_{rms}$	$S = 6 \%V_{dd}/mT$ (= 300 mV/mT @ $V_{dd}=5V$ )			0.1	%Vdd
$V_{oq}$ Ratiometry	$\Delta V_{oq}$	$V_{oq} = 50\%V_{dd}$ $\Delta V_{dd} = 10\%V_{dd}$	9.8		10.2	%
Sensitivity Ratiometry	$\Delta S$	$\Delta V_{dd} = 10\%V_{dd}$ $B = B_{op}$	9.8		10.2	%
Clamped output accuracy	Clamp_lo	Trimming range: 5-10%Vdd	-1		1	%Vdd
	Clamp_hi	Trimming range: 90-95%Vdd				

Table 7: Accuracy specific parameter analog output

### 8.3 Remarks to the achievable accuracy

The achievable target accuracy is dependent on user's end-of-line calibration. The resolution for the offset and offset drift calibration is better than 0.1%Vdd. Trimming capability is higher than the measurement accuracy. End-user calibration can increase the accuracy of the system.



## 9 PWM output specification

### 9.1 Timing specification for the PWM output

Operating Parameters  $T_A = -40$  to  $125^{\circ}\text{C}$ ,  $V_{DD} = 4.5$  V to  $5.5$  V (unless otherwise specified)

Parameter	Symbol	Test Conditions	Min	Typ	Max	Units
Main Oscillator Frequency	$F_{OSC}$	Tolerance $\pm 10\%$	900	1024	1100	kHz
PWM Output Frequency	$F_{PWM}$		110	125	140	Hz
Tick Time (resolution in time domain)	$t_{TICK}$			1		$\mu\text{s}$
PWM Output Resolution	R(PWM)	12 Bit, Theoretical Jitter free		0.025		%DC
PWM Jitter (1 Sigma)	J (PWM)	FILTCODE = 5 (70 Hz Digital LowPass Filter)		0.01		%DC (1 Sigma)
Output Rise Time (10%-90%)	$t_{RISEOD}$	Push-pull mode $R_L = 4.7$ k $\Omega$ to $5$ V, $C_L = 10$ nF OUTSLOPE = 0		11		$\mu\text{s}$
		OUTSLOPE = 1		7		$\mu\text{s}$
		OUTSLOPE = 2		4		$\mu\text{s}$
		OUTSLOPE = 3		2.5		$\mu\text{s}$
Output Fall Time (90%-10%)	$T_{FALLOD}$	Push-pull or open-drain mode $R_L = 4.7$ k $\Omega$ to $5$ V, $C_L = 10$ nF OUTSLOPE = 0		14		$\mu\text{s}$
		OUTSLOPE = 1		8		$\mu\text{s}$
		OUTSLOPE = 2		4.5		$\mu\text{s}$
		OUTSLOPE = 3		2.5		$\mu\text{s}$
Clamped Output Level	Clamp_lo	Programmable	1		10	%DC
	Clamp_hi	Programmable	90		99	%DC
Power-on delay	$T_{POD}$				11	ms

Table 8: Timing specification for the PWM output





### 9.2 Magnetic specification for the PWM output

Operating Parameters  $T_A = -40$  to  $125\text{degC}$ ,  $V_{dd} = 4.5$  V to  $5.5$  V, unless otherwise specified.

Parameter	Symbol	Test Conditions	Min	Typ	Max	Units
Nominal Field Range	Bnom		-20		+20	mT
Operational Field Range <sup>(1)</sup>	Bop		-25		+25	mT
Linearity Error	NL	Nominal Field Range (25°C)	-0.5		+0.5	%FS
		Operational Field Range (25°C)	-0.75		+0.75	%FS
Hysteresis, remanent Field	Br	B = Bop	-25		+25	uT
Programmable Sensitivity	S	B = Bop	0.5		5	%DC/mT
Sensitivity programming Resolution	Sres	B = Bop		0.1		%

Table 9: Magnetic specification 25mT version (high-field version)

(1) Above 25 mT, the IMC starts saturating yielding to an increase of the linearity error.

### 9.3 Accuracy specification transfer characteristic PWM

Operating Parameters  $T_A = -40$  to  $125\text{degC}$ ,  $V_{dd} = 5.0$  V (unless otherwise specified),  $S = 4\%$ DC/mT

Parameter	Symbol	Test Conditions	Min	Typ	Max	Units
Thermal Offset Drift	$\Delta^T V_{oq}$		-0.4		+0.4	%DC
Thermal Sensitivity Drift	TC		-150		+150	ppm/°C

Table 10: Accuracy specific parameter PWM output

## 10 Thermometer output specification

The thermometer output voltage is in the range from 367mV to 2930mV for temperatures ranging from -40 to 150degC. The accuracy is better than 5degC. The pin shall be able to sustain a low impedance connection to maximum 14V. This output is not ratiometric.

Parameter	Symbol	Test Conditions	Min	Typ	Max	Units
Offset	$T_{35}$	Output voltage with $T = 35\text{degC}$		1.38		V
Slope	$T_{\text{slope}}$			13.5		mV/degC
Accuracy	$T_{\text{acc}}$		-5		5	degC
Load capacitor	$C_{\text{loadTherm}}$	External through bonding wire		1	50	nF
Output current	$I_{\text{outtherm}}$		-0.1		+0.1	mA

Table 11: Thermometer output specification



## 11 Programmable items

### 11.1 Parameter table

Customers can re-program the parameters described in the table below by using the Melexis PTC-04 hardware and the Product Specific Functions (PSF) libraries provided by Melexis. We recommend using the latest version of the PSF and the latest version of the firmware with a communication speed of 10kbps (limited by a maximum output capacitor of 50nF). Software and firmware are available on the softdist platform (see contact details on page 25 to request an account).

Parameter	Bits	Factory Setting	Comment
DSPMODE	1	0	Selection analog or PWM output
OUTMODE	1	1	Capacitive load selection in analog mode
		N/A	Push pull or open drain output drive in PWM mode
DIAGINFAULT	1	0	Output impedance setting
REFEDGE	1	0	Not used in analog mode
			Diagnostic level & reference edge
SWITCH	1	N/A	Not used in analog mode
		0	PWM or SWITCH output selection
PLATEPOL <sup>(1)</sup>	1	0	Change of sensitivity sign
ROUGHGAIN	3	Trimmed	Rough gain preamplifier
FINEGAIN	10	Trimmed	Fine gain from 0.4 to 1.0 in analog mode
	13	Trimmed	Fine gain from -3.999 to +3.999 in PWM mode
XA	12	Trimmed	Offset compensation VOQ in analog mode
	14	Trimmed	Digital offset in PWM mode
YA	9	N/A	Not used in analog mode
		32	Rough offset compensation in PWM mode
CLAMPLOW	3	Trimmed	Clamping low level in analog mode
		N/A	Not used in PWM mode
CLAMPHIGH	3	Trimmed	Clamping high level in analog mode
		2	Clamping high and low level for PWM output
FILTCODE	3	0	Analog filter in analog mode
	4	2	Digital filter in PWM mode
OUTSLOPE	2	3	Power limitation of the output driver on high frequencies in analog
			Output slope control for PWM mode
DCDEF	1	0	Not used in analog mode
		1	PWM duty cycle definition
RATIODIS <sup>(1)</sup>	1	0	Disable ratiometry between output signal and supply
		N/A	Not used in PWM mode
TC1ST	7	Trimmed	Sensitivity temperature drift correction first order
TC2ND_COLD	5	Trimmed	Sensitivity temperature drift correction second order for cold
TC2ND_HOT	5	Trimmed	Sensitivity temperature drift correction second order for hot
OFFDRIFT_COLD	6	Trimmed	Offset temperature drift correction for cold temperatures
OFFDRIFT_HOT	6	Trimmed	Offset temperature drift correction for hot temperatures
MLXID	48	Programmed	MLX ID
CSTID	17	N/A	Customer ID

Table 92: Customer programmable items

(1) Changing these parameters has an impact on temperature calibration.

### 11.2 Output mode configuration (DSPMODE, OUTMODE)

DSPMODE activates the PWM or the analog mode for the output signal. OUTMODE configures the output driver.

DSPMODE	OUTMODE	Output Driver
0	0	Fast analog mode, $C_L = 1nF..10nF^{(1)(2)(3)}$
0	1	Normal analog mode, $C_L = 5nF..50nF^{(1)(2)(4)}$
1	0	PWM mode – Open drain
1	1	PWM mode – Push pull

Table 13: Output configuration

(1) See section 16,  $C_L = C_4$ .

(2) Factory setting: DSPMODE = 0, OUTMODE = 1.

(3) For applications directly integrated on a PCB, smaller capacitors are allowed at the output pins.

(4) For a standalone application where a cable is connected at the output of the sensor.

### 11.3 Output impedance mode (DIAGINFAULT)

DIAGINFAULT sets the output impedance mode.

DIAGINFAULT	Output impedance
0	Low impedance mode (normal mode)
1	High impedance mode (diagnostic level)

### 11.4 Reference edge (REFEDGE) – only in PWM mode

REFEDGE defines the diagnostic level and sets the reference edge.

REFEDGE	Reference edge (PWM)
0	Falling edge
1	Rising edge

### 11.5 PWM/switch mode (SWITCH)

In PWM mode, the output can be configured to switch mode.

SWITCH	Operating mode
0	Disable switch mode
1	Enable switch mode



### 11.6 Platepol (PLATEPOL)

The polarity of the Hall plate versus the output signal is programmable by the PLATEPOL parameter.

PLATEPOL	Polarity
0	Positive
1	Negative

Please note that the factory calibration is done with PLATEPOL=0 . Melexis cannot guarantee the magnetic specifications if this parameter is changed during customer calibration.

### 11.7 Sensitivity programming (ROUGHGAIN, FINEGAIN)

The sensitivity is programmable with 3 bits for ROUGHGAIN and 10 bits for FINEGAIN in analog output application from 60 to 330 V/T (91206-High-Field version) and from 200 to 700 V/T (Low-Field version). The FINEGAIN resolution depends on the programmed ROUGHGAIN setting. It typically ranges from 0.25V/T (ROUGHGAIN=7) up to 0.01V/T (ROUGHGAIN=0).

Different option codes correspond to different sensitivity ranges:

Ordering Option Code	IMC Version	Typical Sensitivity	Minimum Sensitivity	Maximum Sensitivity
CAL-001	Low field	580 mV/mT	460 mV/mT	700 mV/mT
CAL-002		380 mV/mT	300 mV/mT	470 mV/mT
CAL-003		250 mV/mT	200 mV/mT	310 mV/mT
CAH-001	High field	270 mV/mT	210 mV/mT	330 mV/mT
CAH-002		170 mV/mT	130 mV/mT	220 mV/mT
CAH-003		110 mV/mT	80 mV/mT	140 mV/mT
CAH-004		77.5 mV/mT	60 mV/mT	110 mV/mT
CAH-104		3 %DC/mT	0.5 %DC/mT	5 %DC/mT

In order to have a safety margin regarding mechanical tolerances Melexis recommends designing the application in such a way that the typical sensitivity can be used with. If the target sensitivity of the module is out of the defined range (see table above), the hardware and software tools provided by Melexis will not be able to properly calibrate the sensor.

Different option codes correspond to different electric gains:

Ordering Option Code	IMC Version	Typical Rough Gain	Electrical Gain	Typical Voq drift [mV]	Typical Noise [mV RMS]
CAL-001	Low field	7	240	18	5
CAL-002		6	155	14	3.5
CAL-003		5	100	9	2.5
CAH-001	High field	7	240	18	5
CAH-002		6	155	14	3.5
CAH-003		5	100	9	2.5

Since noise and offset drift of the sensor are proportional to the electric gain of the sensor, Melexis recommends using the version with the smallest gain to optimize the performances.

Note: Power consumption is 2mA less if ROUGHGAIN ≤ 3



### 11.8 Offset / output quiescent voltage programming (XA, YA)

#### XA

In analog mode

- 12-bit register
- Offset compensation before gain
- @ 0 Gauss w/o offset & @Vdd=5V →  $V_{out} = 6.25 * (VOQ \text{ Code}) / 4096$  (clipping can occur!)
- Programming resolution: 1.5mV per LSB over the full output range. This corresponds to a calibration resolution of 0.03%Vdd

In PWM mode

- 14-bit register – digital offset VOQ
- Offset compensation before gain

#### YA

Not used in analog mode

In PWM mode

- 9-bit register
- Rough offset compensation (after gain)

### 11.9 Clamping level programming (CLAMPLOW, CLAMPHIGH)

The clamping levels limit the maximum output levels. CLAMPLOW is not used in PWM application. The clamping levels are ratiometric (if RATIODIS = 0)

CLAMPLOW	Minimal output [%Vdd]
0	4.8
1	5.7
2	6.6
3	7.5
4	8.4
5	9.3
6	10.2
7	11.2

Table 14: Clamping low level table analog (typical values)



CLAMPHIGH	Maximal output [%Vdd]
0	90.6
1	91.4
2	92.4
3	93.3
4	94.3
5	95.2
6	96.1
7	97

Table 15: Clamping high level analog mode (typical values).

The clamping functionality can be disabled by programming CLAMPLOW=CLAMPHIGH=7

CLAMPHIGH	Minimal output [%DC]	Maximal output [%DC]
0	1	99
1	4	96
2	5	95
3	6	94
4	7	93
5	8	92
6	9	91
7	10	90

Table 16: Clamping low and high duty-cycle in PWM mode.

The clamping functionality can be disabled by programming CLAMPLOW=CLAMPHIGH=7.

The clamping levels calibrated during final test are:

- 6%Vdd (+/- 0.5%Vdd) for CLAMPING LOW
- 94%Vdd (+/- 0.5%Vdd) for CLAMPING HIGH

### 11.10 Bandwidth and filter programming (FILTCODE)

FILTCODE allows adjusting the internal bandwidth of the sensor in order to optimize for speed or resolution.

FILTCODE	Typical Bandwidth [kHz]
0	90 <sup>(1)</sup>
1	9
2	40
3	2
4	9
5	0.9
6	4
7	0.2

Table 17: FILTCODE settings analog mode

(1) Factory settings: FILTCODE = 0.



FILTCODE	Cut-off frequency [Hz]	Attenuation [dB]	Tau [ms]
2	557	-8.0	0.29
3	279	-11.2	0.57
4	139	-14.4	1.14
5	70	-18.1	2.29
6	35	-22.4	4.57
7	17	-27.1	9.14
8	9	-32.3	18.29
9	4	-38.1	36.57

Table 18: FILTCODE settings PWM mode

**Note:**

- In analog mode values above 7 are not used
- In PWM mode values below 2 and above 9 are not used

### 11.11 Power limitation / PWM rise and fall time (OUTSLOPE)

OUTSLOPE, in the analog mode case, defines the power limit above which the output driver turns off to prevent damages to the IC.

The power dissipated in the IC output driver is measured by the IC itself. The power is obtained by multiplying continuously the voltage across the conducting MOS driver by the output current  $I_{out}$ . When the power reaches the power limit, the output driver is switched off and on such that, on average, the measured power is maintained equal to the power limit. The power limitation is disabled when OUTSLOPE=3.

Value	Power limitation [mW]
0	50
1	100
2	200
3	DISABLED <sup>(1)</sup>

Table 19: Output power limitation in analog mode

(1) Factory settings: OUTSLOPE = 3.

OUTSLOPE, in the PWM mode case, defines the rise and fall times of the PWM transients.

Value	Typical Rise Time	Typical Fall Time	Current Limitation [mA]
0	11	14	5
1	7	8.5	7
2	4	4.5	13
3	2.5	2.5	22

Table 20: PWM rise and fall time,  $C_{out} = 10nF$ ,  $R_{pullup} = 4.7k\Omega$



### 11.12 PWM Mode duty cycle definition (DCDEF)

The PWM duty cycle definition is as follows.

DCDEF	PWM duty cycle definition
0	tLow / (tLow + tHigh)
1	tHigh / (tLow + tHigh)

Table 21: PWM duty cycle definition

### 11.13 Output ratiometry (RATIODIS)

In case of analog mode (DSPMODE=0) RATIODIS allows enabling and disabling the ratiometry of the output in reference to the supply voltage by setting respectively 0 and 1 in the EEPROM.

RATIODIS	Ratiometry
0	Enabled
1	Disabled

Please note that the factory calibration is done with RATIODIS=0 . Melexis cannot guarantee the magnetic specification if this parameter is changed during customer calibration.

### 11.14 Sensitivity and temperature drift programming (TC1ST, TC2ND\_COLD, TC2ND\_HOT)

First order sensitivity temperature drift can be trimmed from -2000 to 2000 ppm/degC with TC1ST. The programming resolution is 40 ppm/degC.

Second order sensitivity temperature drift can be trimmed from -6 to 6 ppm/degC<sup>2</sup> with TC2ND. The programming resolution is 0.4/ppm/degC<sup>2</sup>. The second order can also be seen as third order correction since cold and hot sides are independently adjusted.

### 11.15 Offset temperature drift programming (OFFDRIFT\_COLD, OFFDRIFT\_HOT)

Offset temperature drift can be trimmed from -2.25 to +2.25 mV/degC. The programming resolution is 0.075 mV/degC.

This first order correction is done independently for temperatures over 25degC and below 25degC. The offset drift corrections are ratiometric (if RATIODIS = 0)



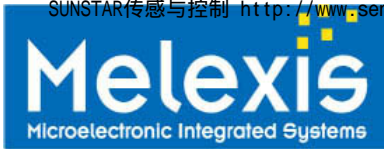

### 11.16 Product Identification (MLXID, CSTID)

#### MLXID

A 48-bit MLX ID is used to guarantee MLX traceability (lotnumber, wafernumber, wafer position & option code) and is split up in 3x a 16 bit register (MLXID1, MLXID2 & MLXID3)  
The programmed option code is stored in MLXID3[2..0]:

PSF Option Code <sup>(1)</sup> MLXID3[2..0]	Ordering Option Code <sup>(2)</sup>
7	CAL-001 / CAH-001
6	CAL-002 / CAH-002
5	CAL-003 / CAH-003
4	CAH-004 / CAH-104

- (1) The option code mentioned in all 91206 related documentation (application notes, PSF and User Interface) refers to the PSF Option Code.  
(2) The Ordering Option Code mentioned on the page 1 of this datasheet refers to the Ordering Code, which defines the Chip version and the sensitivity range of the sensor

#### CSTID

A 17-bit customer ID is available to create a dedicated traceability system  
Self-diagnostic

The MLX91206 provides numerous self-diagnostic features. Those features increase the robustness of the IC functionality as it prevents the IC to provide erroneous output signal in case of internal or external failure modes.

Error	Action	Effect on Outputs	Remarks
Calibration Data CRC Error (at power up and in normal working mode)	Fault mode	High Impedance mode <sup>(1)</sup>	Pull down resistive load => Diag Low Pull up resistive load => Diag High
Power On delay		High Impedance mode <sup>(1)</sup>	1 ms max in high impedance followed by settling
Undervoltage Mode <sup>(4)</sup>	IC is reset <sup>(7)</sup>	High Impedance mode <sup>(1)</sup>	300mV Hysteresis
Overvoltage detection Mode 1 <sup>(5)</sup> (Threshold : min 7.9 V – max 9.5 V)	IC is switched off (internal supply)	High Impedance mode <sup>(1)</sup>	I <sub>dd</sub> < 1mA 500 to 1500mV Hysteresis
Overvoltage detection Mode 2 <sup>(6)</sup> (Threshold : min 6.8V – max 7.5V)	IC is reset <sup>(7)</sup>	High Impedance mode <sup>(1)</sup>	100mV Hysteresis
Broken Vss	IC is switched off	High Impedance <sup>(2)</sup>	With some restrictions on pull-up/pull-down resistors on OUT and TEMPOUT, see Chap. 6 ,Table 3
Broken Vdd	IC is switched off	High Impedance <sup>(3)</sup>	With some restrictions on pull-up/pull-down resistors on OUT, see Chap. 6 , Table 3

Table 22: Self diagnostic

- (1) Refer to Table 3: General electrical parameter, parameter High-impedance modes levels  
(2) Refer to Table 3: General electrical parameter, parameter BrokenVss Output Level  
(3) Refer to Table 3: General electrical parameter, parameter BrokenVdd Output Level  
(4) Refer to Table 3: General electrical parameter, parameter Under-voltage detection  
(5) Refer to Table 3: General electrical parameter, parameter Over-voltage detection mode 1  
(6) Refer to Table 3: General electrical parameter, parameter Over-voltage detection mode 2  
(7) The internal supply is regulated but the digital sequencer (hall element spinning) is stopped

## 12 Application information

### 12.1 Low current measurement up to ±2 A

Low currents can be measured with the MLX91206 by increasing the magnetic field via a coil around the sensor. The sensitivity (output voltage vs. current in coil) of the measurement will depend on the size of coil and number of turns. Additional sensitivity and increased immunity to external fields can be gained by adding a shield around the coil. The bobbin provides very high dielectric isolation making this a suitable solution for high voltage power supplies with relative low currents. The output should be scaled to obtain the maximum voltage for the highest current to be measured in order to obtain the best accuracy and resolution.

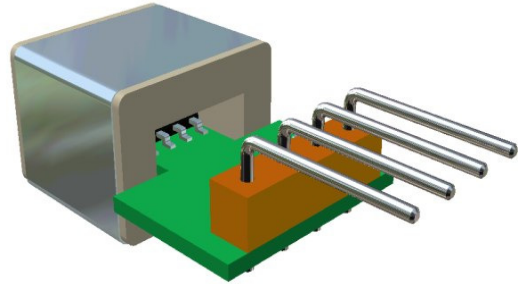

Figure 3: Low current application

### 12.2 Medium current up to ±30 A

With a single conductor located on the PCB, currents in the range of up to 30 amps can be measured. The sizing of the PCB trace needs to take into account the current handling capability and the total power dissipation. The PCB trace needs to be thick enough and wide enough to handle the RMS current continuously.

The differential output voltage for this configuration can be approximated by the following equation:

$$V_{out} = 35 \text{ mV/A} * I$$

For a current level of 30 A, the output will be approximately 1050 mV.

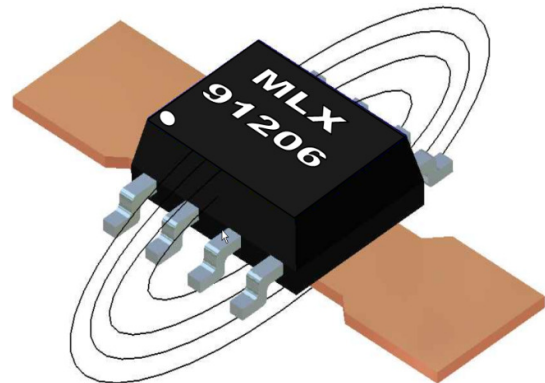

Figure 4: Medium current application

### 12.3 High current measurement up to ±600 A

Another method of measuring high currents on PCB's is to use a large thick gauge copper trace capable of carrying the current on the opposite side of the PCB. The MLX91206 should be located near the centre of the trace, however because the trace is wide, the output is less sensitive to location on the PCB. This configuration also has less sensitivity due to the distance and width of the conductor.



Figure 5: High current application

## 13 Recommended Application Diagrams

### 13.1 Resistor and capacitor values

All mentioned component values can have a  $\pm 20\%$  tolerance

Part	Description	Value	Unit
C1	Supply capacitor, EMI, ESD	10 - 220	nF
C2	Regulator buffer capacitor, decoupling, EMI, ESD	10 - 220	nF
C3	Decoupling, EMI, ESD	5 - 50	nF
C4	Decoupling, EMI, ESD	5 - 50 <sup>(1)</sup>	nF
R1	Pull up or pull down load resistor	10 - 30	k $\Omega$

Table 23: Resistor and capacitor value

(1) When OUTMODE=0, which we do not advice in application, capacitor C4 should be 1nF or less.

### 13.2 Fast analog application, pull-down resistor for diagnostic low

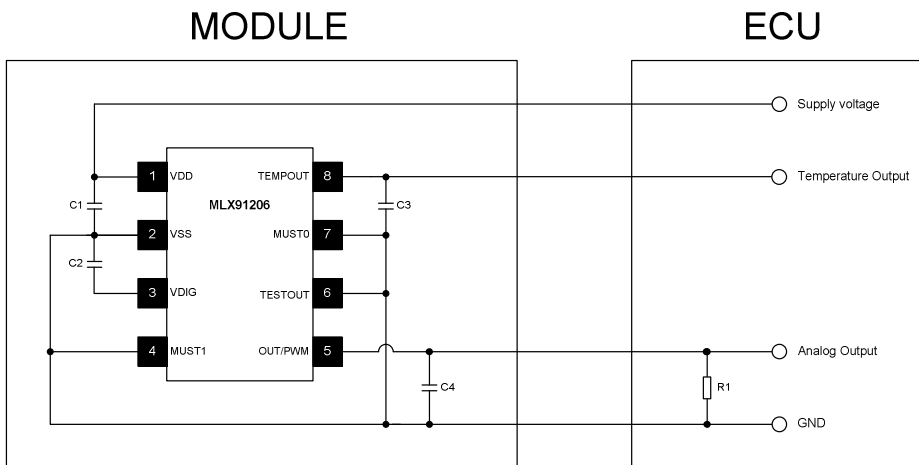

Figure 6: Fast analog application, Pull-down resistor

**13.3 Fast analog application, pull-up resistor for diagnostic high**

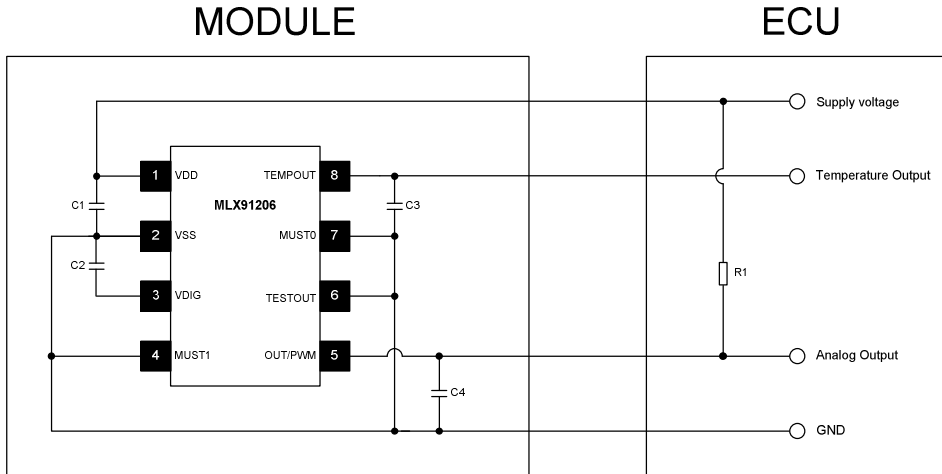

Figure 7: Fast analog application, Pull-up resistor

**13.4 Robust PWM application, (pull-up load only)**

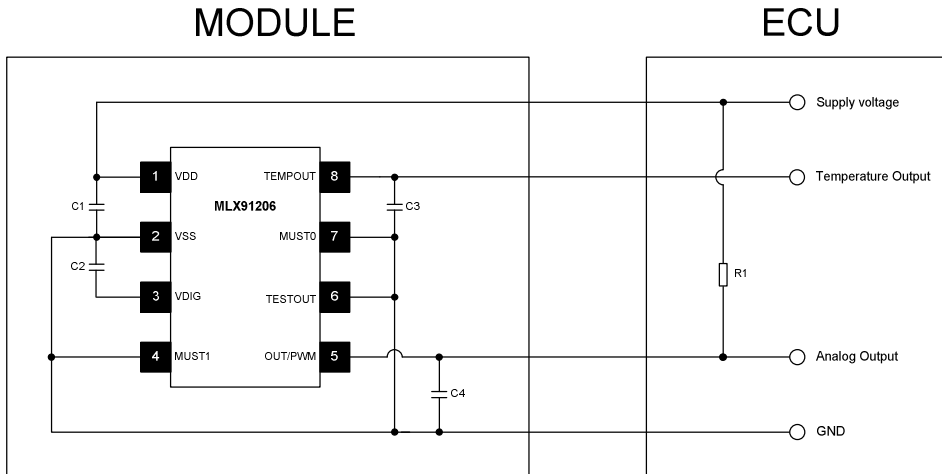

Figure 8: Robust PWM application with pull-up resistor

## **14 Standard information regarding manufacturability of Melexis products with different soldering processes**

Our products are classified and qualified regarding soldering technology, solderability and moisture sensitivity level according to following test methods:

### **Reflow Soldering SMD's (Surface Mount Devices)**

- IPC/JEDEC J-STD-020  
Moisture/Reflow Sensitivity Classification for Nonhermetic Solid State Surface Mount Devices (classification reflow profiles according to table 5-2)
- EIA/JEDEC JESD22-A113  
Preconditioning of Nonhermetic Surface Mount Devices Prior to Reliability Testing (reflow profiles according to table 2)

### **Wave Soldering SMD's (Surface Mount Devices) and THD's (Through Hole Devices)**

- EN60749-20  
Resistance of plastic- encapsulated SMD's to combined effect of moisture and soldering heat
- EIA/JEDEC JESD22-B106 and EN60749-15  
Resistance to soldering temperature for through-hole mounted devices

### **Iron Soldering THD's (Through Hole Devices)**

- EN60749-15  
Resistance to soldering temperature for through-hole mounted devices

### **Solderability SMD's (Surface Mount Devices) and THD's (Through Hole Devices)**

- EIA/JEDEC JESD22-B102 and EN60749-21  
Solderability

For all soldering technologies deviating from above mentioned standard conditions (regarding peak temperature, temperature gradient, temperature profile etc) additional classification and qualification tests have to be agreed upon with Melexis.

The application of Wave Soldering for SMD's is allowed only after consulting Melexis regarding assurance of adhesive strength between device and board.

Melexis is contributing to global environmental conservation by promoting **lead free** solutions. For more information on qualifications of **RoHS** compliant products (RoHS = European directive on the Restriction Of the use of certain Hazardous Substances) please visit the quality page on our website:

<http://www.melexis.com/quality.aspx>

## **15 ESD Precautions**

Electronic semiconductor products are sensitive to Electro Static Discharge (ESD). Always observe Electro Static Discharge control procedures whenever handling semiconductor products.

### 16 Package Information

#### 16.1 SOIC8 Package dimensions

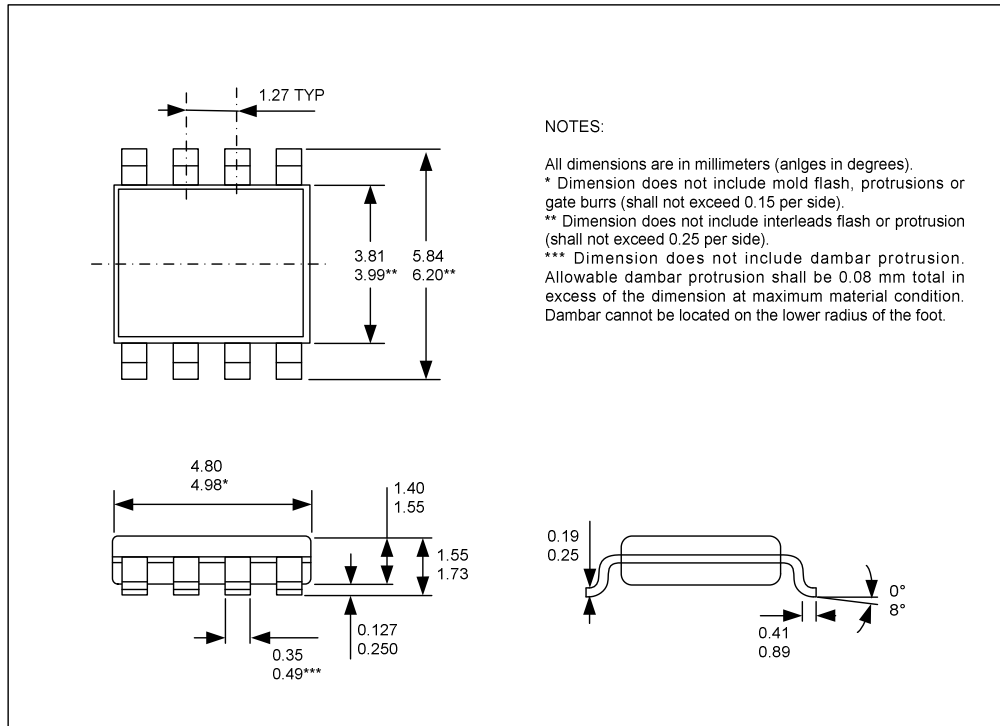

Figure 9: Package dimensions

#### 16.2 SOIC8 Pinout and Marking

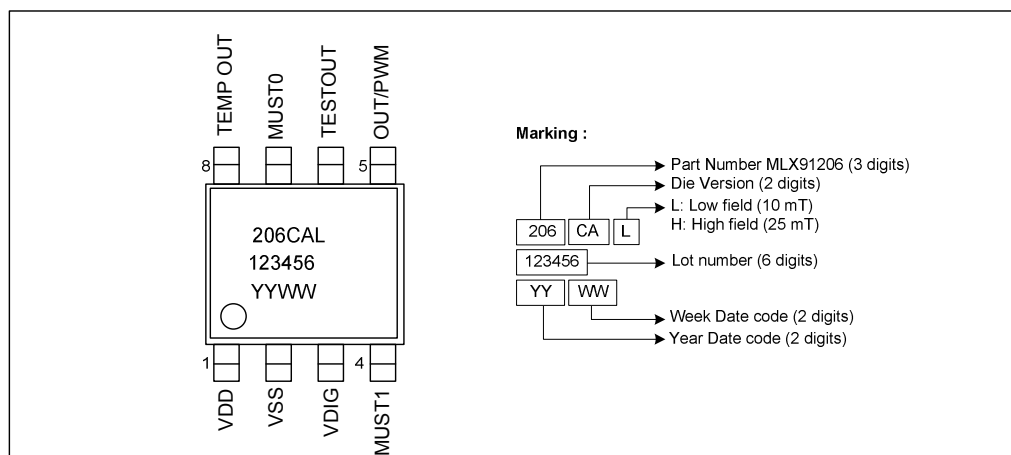

Figure 10: Pinout and marking

**Note:** the option code is not marked on the package. It can be found back in the EEPROM (see chapter 11.12) and on the tape-on-reel label information.

### 16.3 SOIC8 Hall plate position

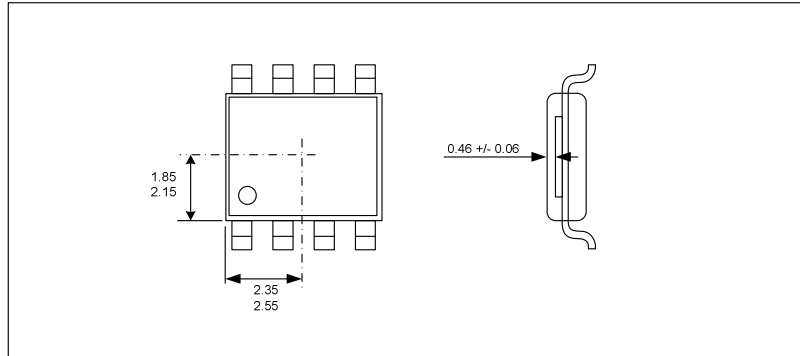

Figure 11: Hall Plate positioning

### 16.4 IMC Position and sensors active measurement direction

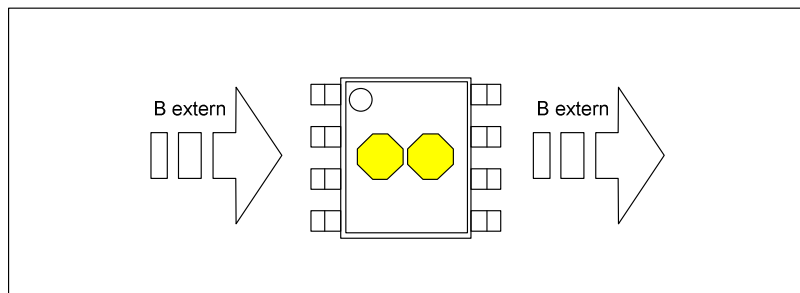

Figure 12: IMC position and geometry Low-Field version

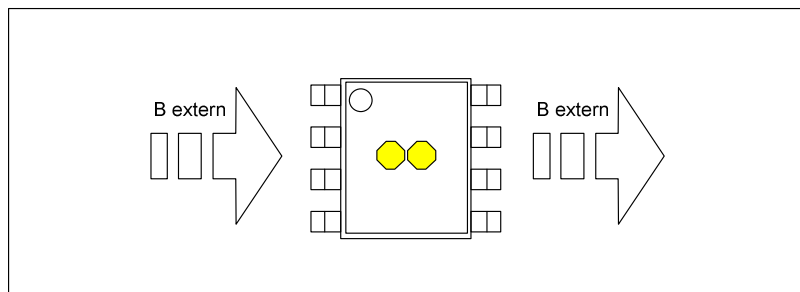

Figure 13: IMC position and geometry High-Field version

---

## **17 Related documents and tools**

### **17.1 Related documents**

- User Interface UI MLX91206 Description
- Product Specific Functions PSF MLX91206 Description
- PTC-04 Daughter Board DB-HALL-03 Data Sheet

The latest version of these documents is available on the Melexis Softdist platform. Please contact your local sales office to request an account (see contact details on page 25).

- Non intrusive current sensing with MLX91206 application note
- MLX91206 for PDU solutions application note
- Calibrating the MLX91206/MLX91207 application note
- Shielding for Triaxis current sensors application note

The latest version of these documents is available on the MLX91206 page on the Melexis website:

<http://www.melexis.com/Hall-Effect-Sensor-ICs/Special-Purpose-Hall-ICs/MLX91206-755.aspx>

### **17.2 Related software**

- MLX91206 Firmware
- MLX91206 Product Specific Functions (PSF)
- MLX91206 User Interface
- MLX PTC-04 Product Specific Functions
- MLX PTC-04 User Interface

The latest version of these pieces of software is available on the Melexis Softdist platform. Please contact your local sales office to request an account (see contact details on page 25).

### **17.3 Related hardware**

- PTC-04 Programmer for Melexis PTC devices
- PTC-04 Daughter Board DB-HALL-03 for MLX91206





## 18 Disclaimer

Devices sold by Melexis are covered by the warranty and patent indemnification provisions appearing in its Term of Sale. Melexis makes no warranty, express, statutory, implied, or by description regarding the information set forth herein or regarding the freedom of the described devices from patent infringement. Melexis reserves the right to change specifications and prices at any time and without notice. Therefore, prior to designing this product into a system, it is necessary to check with Melexis for current information. This product is intended for use in normal commercial applications. Applications requiring extended temperature range, unusual environmental requirements, or high reliability applications, such as military, medical life-support or life-sustaining equipment are specifically not recommended without additional processing by Melexis for each application.

The information furnished by Melexis is believed to be correct and accurate. However, Melexis shall not be liable to recipient or any third party for any damages, including but not limited to personal injury, property damage, loss of profits, loss of use, interrupt of business or indirect, special incidental or consequential damages, of any kind, in connection with or arising out of the furnishing, performance or use of the technical data herein. No obligation or liability to recipient or any third party shall arise or flow out of Melexis' rendering of technical or other services.

© 2012 Melexis NV. All rights reserved.

For the latest version of this document, go to our website at  
**[www.melexis.com](http://www.melexis.com)**

Or for additional information contact Melexis Direct:

Europe, Africa, Asia:  
Phone: +32 1367 0495  
E-mail: [sales\\_europe@melexis.com](mailto:sales_europe@melexis.com)

America:  
Phone: +1 248 306 5400  
E-mail: [sales\\_usa@melexis.com](mailto:sales_usa@melexis.com)

ISO/TS 16949 and ISO14001 Certified