

SO2-BE Sulfur Dioxide Sensor

High Concentration



Figure 1 SO2-BE Schematic Diagram

PATENTED

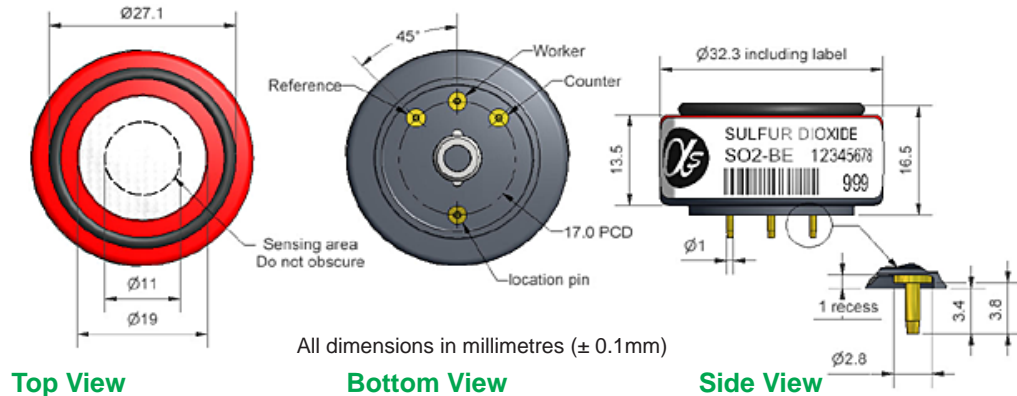

Technical Specification

PERFORMANCE	Sensitivity	nA/ppm in 20ppm SO ₂	70 to 85
	Response time	t ₉₀ (s) from zero to 20ppm SO ₂	< 30
	Zero current	ppm equivalent in zero air	< ± 2
	Resolution	RMS noise (ppm equivalent)	< 2
	Range	ppm limit of performance warranty	2,000
	Linearity	ppm error at full scale, linear at zero and 20ppm SO ₂	nd
	Overgas limit	maximum ppm for stable response to gas pulse	10,000
LIFETIME	Zero drift	ppm equivalent change/year in lab air	nd
	Sensitivity drift	% change/year in lab air, monthly test	nd
	Operating life	months until 80% original signal (24 month warranted)	> 24
ENVIRONMENTAL	Sensitivity @ -20°C% (output @ -20°C/output @ 20°C) @ 20ppm		80 to 90
	Sensitivity @ 50°C% (output @ 50°C/output @ 20°C) @ 20ppm		95 to 105
	Zero @ -20°C	ppm equivalent change from 20°C	< ± 1
	Zero @ 50°C	ppm equivalent change from 20°C	< -1 to 10
CROSS SENSITIVITY	Filter capacity	ppm·hrs	4,000
	H ₂ S sensitivity	% measured gas @ 20ppm H ₂ S	< 2
	NO ₂ sensitivity	% measured gas @ 10ppm NO ₂	< -180
	Cl ₂ sensitivity	% measured gas @ 10ppm Cl ₂	< 35
	NO sensitivity	% measured gas @ 50ppm NO	< -30
	CO sensitivity	% measured gas @ 400ppm CO	< 8
	H ₂ sensitivity	% measured gas @ 400ppm H ₂	< 1.5
	C ₂ H ₄ sensitivity	% measured gas @ 400ppm C ₂ H ₄	< 0.1
NH ₃ sensitivity	% measured gas @ 20ppm NH ₃	< 0.1	
KEY SPECIFICATIONS	Temperature range	°C	-30 to 50
	Pressure range	kPa	80 to 120
	Humidity range	% rh continuous (see note below)	15 to 90
	Storage period	months @ 3 to 20°C (stored in sealed pot)	6
	Load Resistor	Ω (recommended)	10 to 47
	Weight	g	< 13

Note: Above 85% rh and 40°C a maximum continuous exposure period of 10 days is warranted. Where such exposure occurs the sensor will recover normal electrolyte volumes when allowed to rest at lower % rh and temperature levels for several days.



NOTE: all sensors tested and stored at ambient environments unless otherwise stated. As applications of use are outside our control, the information provided is given without legal responsibility. Customers should test under their own conditions, to ensure that the sensors are suitable for their own requirements.

SO2-BE Performance Data

Technical Specification

Figure 2 Sensitivity Temperature Dependence

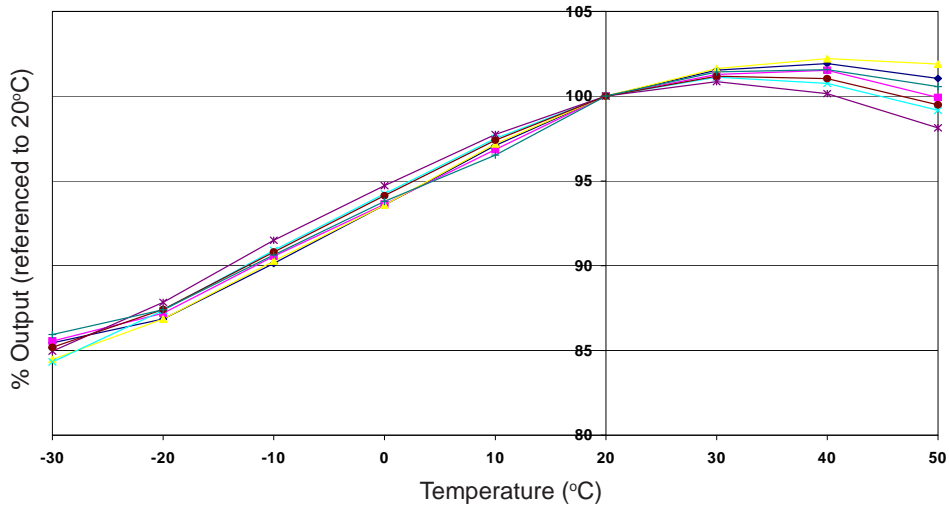

Figure 2 shows the variation in sensitivity caused by changes in temperature.

This data is taken from a typical batch of sensors.

Figure 3 Zero Temperature Dependence

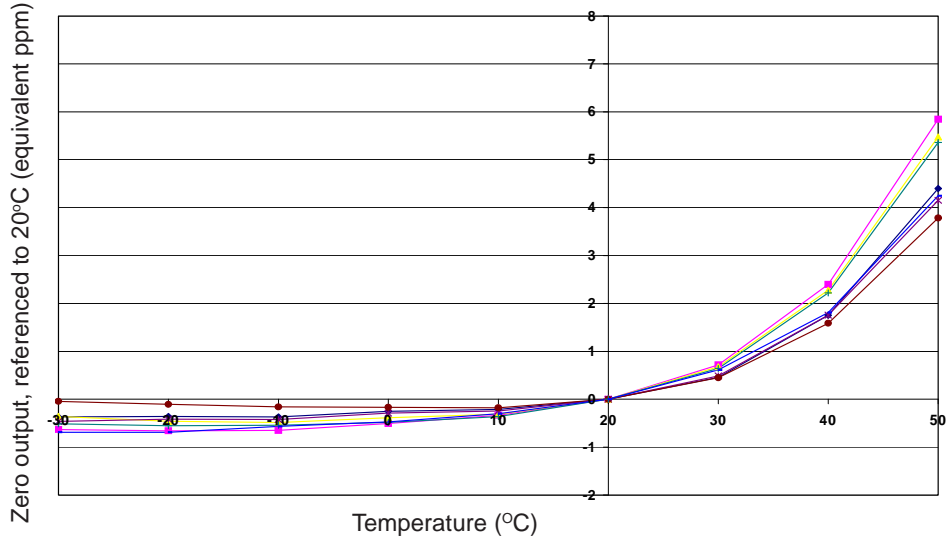
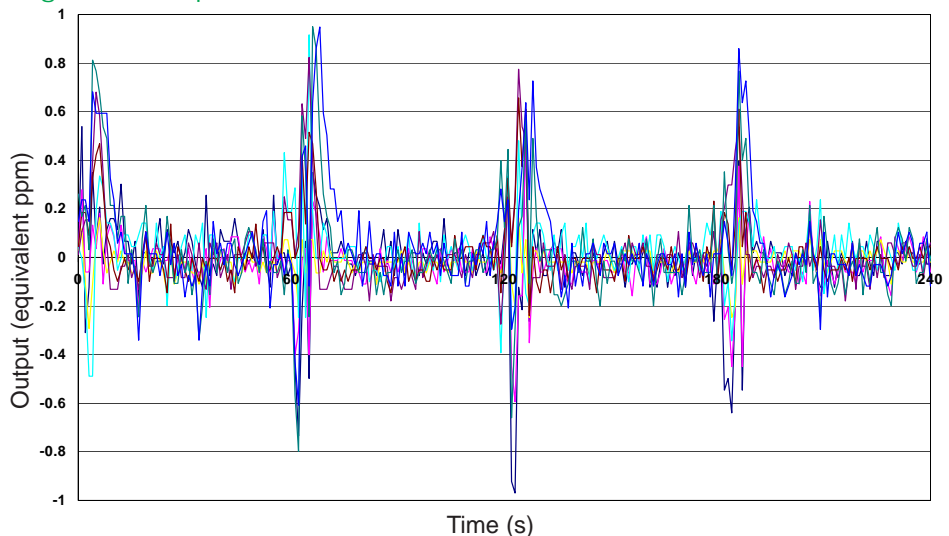

Figure 3 shows the variation in zero output caused by changes in temperature, expressed as ppm gas equivalent, referenced to zero at 20°C.

This data is taken from a typical batch of sensors.

Figure 4 Response breath test



Simply breathing on a sensor causes both temperature and humidity transients.

The SO2-BE recovers rapidly, returning to zero after four consecutive breaths.