

# General Purpose Relay

# G7J

- Ideal for 3-phase motor control applications and resistive and inductive loads
- No contact chattering for momentary voltage drops up to 50% of rated voltage
- Withstands more than 4 kV between contacts that are of different polarity and between the coil and contacts
- Flame-resistant materials (UL94V-0) used for all insulation
- Push-to-test button on all models lets user check contact operation

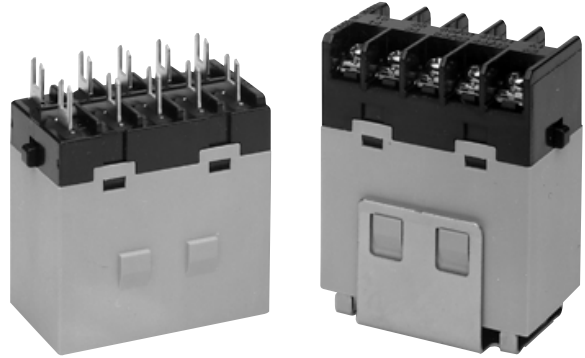

## Ordering Information

To Order: Select the part number and add the desired coil voltage rating (e.g., G7J-3A1B-B-AC100/120).

Type	Contact form	Part number		
		Quick-connect terminal	Screw terminal	PCB terminal
PCB mounting	4PST-NO	—	—	<b>G7J-4A-P</b>
	3PST-NO/SPST-NC	—	—	<b>G7J-3A1B-P</b>
	DPST-NO/DPST-NC	—	—	<b>G7J-2A2B-P</b>
W-bracket (see note)	4PST-NO	<b>G7J-4A-T</b>	<b>G7J-4A-B</b>	
	3PST-NO/SPST-NC	<b>G7J-3A1B-T</b>	<b>G7J-3A1B-B</b>	
	DPST-NO/DPST-NC	<b>G7J-2A2B-T</b>	<b>G7J-2A2B-B</b>	

Note: The G7J-B relays require a W-bracket for mounting. Order the bracket separately below. To order a relay and bracket packed together, add "-W1" to the part number before the coil voltage suffix. For example, G7J-2A2B-B-W1-AC100/120.

### ACCESSORIES

Types	Applicable relays	Part number
W-brackets	G7J-4A-B, G7J-3A1B-B, G7J-2A2B-B	<b>R99-04-FOR-G5F</b>

### TYPICAL APPLICATIONS

Compressors for air conditioners and heater switching controllers.

Switching controllers for power tools or motors.

Lamp controls, motor drivers, and power supply switching controllers in copy machines, facsimile machines, and other office equipment.

Power controllers for packers or food processing equipment.

Power controllers for inverters.



# Specifications

## ■ CONTACT DATA

Load	Resistive load (p.f. = 1)	
	NO	NC
Rated load	25 A, 220 VAC (24 A, 230 VAC), 25 A, 30 VDC	8 A, 220 VAC (7.5 A, 230 VAC), 8 A, 30 VDC
Rated carry current	25 A	8 A
Max. switching voltage	250 VAC, 125 VDC	
Max. switching current	25 A	8 A
Max. switching capacity	5,500 VA, 750 W DC	1,760 VA, 240 W DC
Min. permissible load	100 mA, 24 VDC at 120 operations/minute, 23°C (73°F) ambient temperature)	

## ■ COIL DATA

### AC

Coil voltage	Rated voltage (VAC)	Rated current (mA)	Coil resistance (Ω)	Must operate	Must release	Max. voltage	Power consumption
				% of rated voltage			
24	24	75	—	75% max.	15% min.	110%	Approx. 1.8 to 2.6 VA
50	50	36	—				
100/120	100 to 120	18 to 21.60	—	75 volts	18 volts	132 volts	
200/240	200 to 240	9 to 10.80	—	150 volts	36 volts	264 volts	

### DC

Coil voltage	Rated voltage (VDC)	Rated current (mA)	Coil resistance (Ω)	Must operate	Must release	Max. voltage	Power consumption
				% of rated voltage			
12	12	167	72	75% max.	10% min.	110%	Approx. 2.0 W
24	24	83	288				
48	48	42	1150				
100	100	20	5000				
110	110	18	6050				

Note: 1. The rated current and coil resistance are measured at a coil temperature of 23°C (73°F) with tolerances of +15%/-20% for AC rated current and ±15% for DC coil resistance.  
 2. Performance characteristic data are measured at a coil temperature of 23°C (73°F).

## COIL INTERNAL CIRCUIT

### AC operating coil

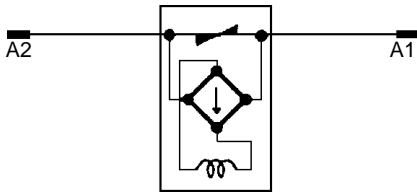

The G7J incorporates a bridge rectifier circuit in the AC coil versions that prevents contact chatter or dropout during a voltage drop. This circuit allows the relays to withstand, with no vibration or shock, voltage drops to the coil of up to 50% of the rated coil voltage for one second maximum.

### DC operating coil

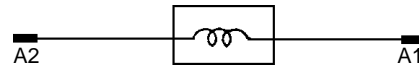

As a rule, either a DC battery or a DC power supply with a maximum of 5% ripple must be used for the operating voltage for DC relays. Before using a rectified AC supply, confirm that the ripple is not greater than 5%. Ripple greater than this can lead to variations in the operating and reset voltages. As excessive ripple can generate pulses, the insertion of a smoothing capacitor is recommended as shown below.

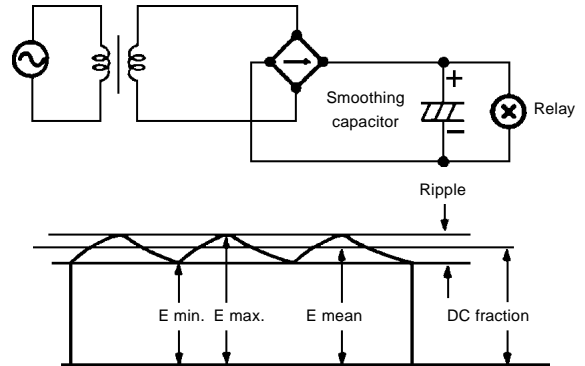

$$\% \text{ of ripple} = \frac{E \text{ max.} - E \text{ min.}}{E \text{ mean}} \times 100$$

E max.: Maximum ripple

E min.: Minimum ripple

E mean: Mean DC voltage value

When driving the coil with a transistor, check the leakage current and connect a bleeder resistor if necessary.

## CHARACTERISTICS

Contact resistance		50 mΩ max.
Operating time		50 ms max.
Release time		50 ms max.
Operating frequency	Mechanical	1,800 operations/hour max.
	Electrical	1,800 operations/hour max.
Insulation resistance		1,000 MΩ minimum at 500 VDC
Dielectric strength		4,000 VAC, 50/60 Hz for 1 minute between coil and contacts
		4,000 VAC, 50/60 Hz for 1 minute between contacts of different polarity
		2,000 VAC, 50/60 Hz for 1 minute between contacts of the same polarity
Impulse withstand voltage		10,000 V between coil and contact with 1.2 x 50 μs impulse wave
Vibration	Mechanical durability	10 to 55 Hz, 1.50 mm (0.06 in) double amplitude
	Malfunction durability	NO: 10 to 55 Hz, 1.50 mm (0.06 in) double amplitude
		NC: 10 to 26 Hz, 1.50 mm (0.06 in) double amplitude
Shock	Mechanical durability	1000 m/s <sup>2</sup> (Approx. 100 G)
	Malfunction durability	NO: 100 m/s <sup>2</sup> (Approx. 10 G)
		NC: 20 m/s <sup>2</sup> (Approx. 2 G)
Service life	Mechanical	1 million operations minimum at 1,800 operations/hour
	Electrical	100,000 operations minimum at 1,800 operations/hour at rated load
Ambient temperature	Operating	-25° to 60°C (-13° to 140°F) with no icing
Humidity	Operating	35% to 85% RH
Weight	PCB terminal	Approx. 140 g (4.90 oz.)
	Screw terminal	Approx. 165 g (5.80 oz.)

Note: Data shown are of initial value.

■ CHARACTERISTIC DATA

Maximum switching capacity

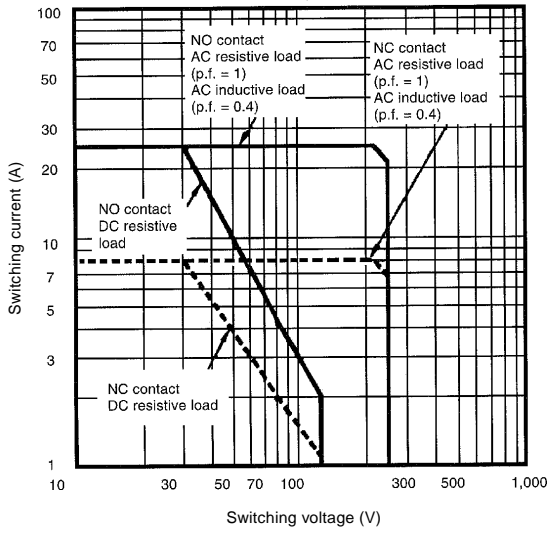

Electrical service life

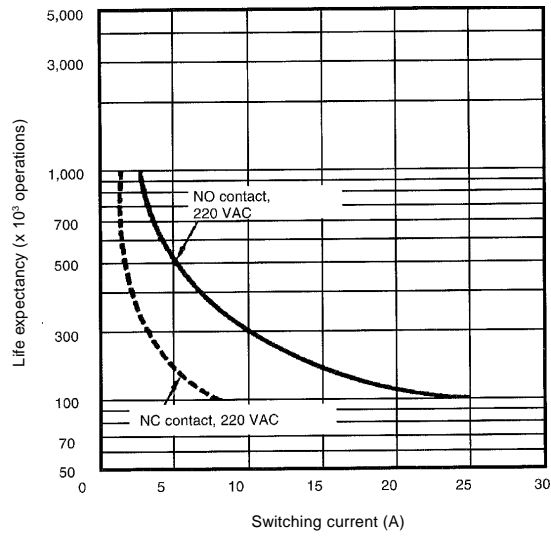

Dimensions

Unit: mm (inch)

■ RELAYS

PCB Terminals with PCB Mounting  
G7J-4A-P, G7J-3A1B-P, G7J-2A2B-P

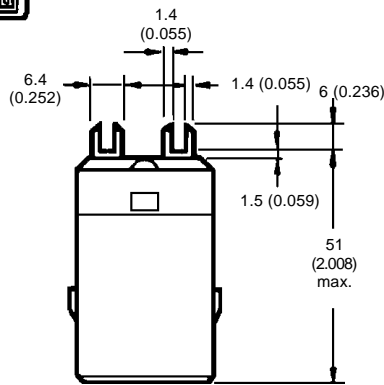
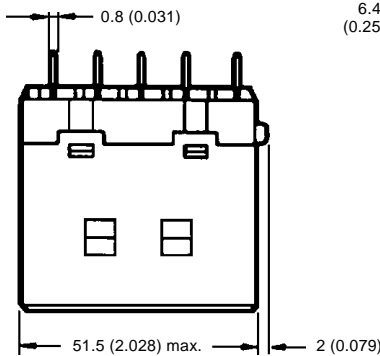
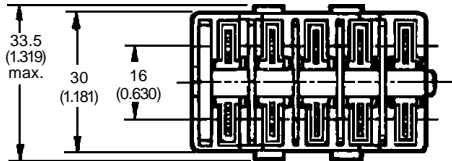

Mounting holes  
(Bottom view)

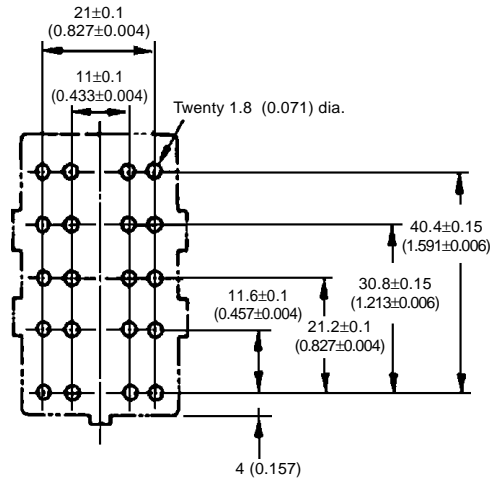

**Screw Terminals (requires W-bracket for mounting)**  
**G7J-4A-B, G7J-3A1B-B, G7J-2A2B-B**

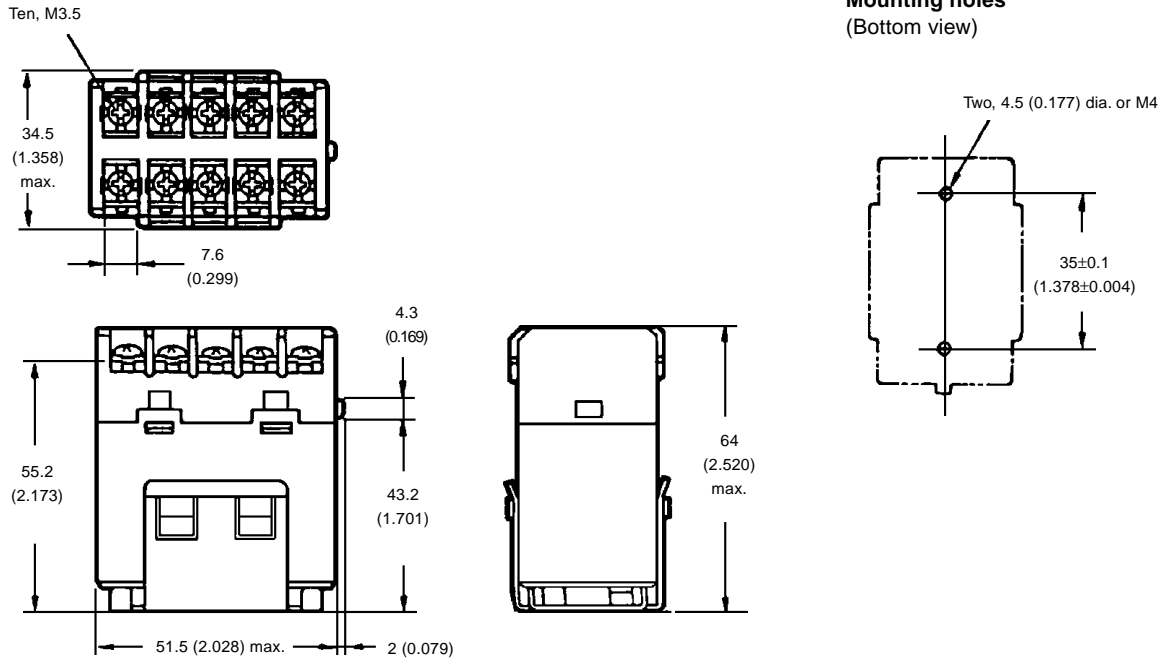

■ **ACCESSORIES**

**W-Bracket for G7J-B Relays with Screw Terminals**  
**R99-04-FOR-G5F**

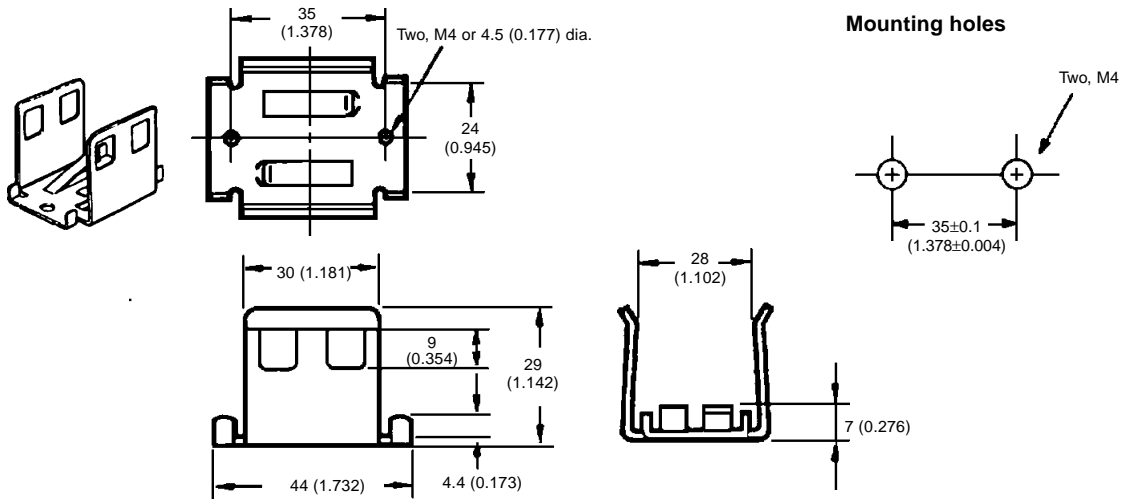

■ **TERMINAL ARRANGEMENT – INTERNAL CONNECTIONS**

**G7J-4A-P(B)**

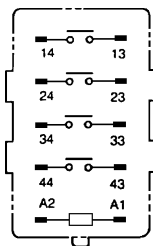

**G7J-3A1B-P(B)**

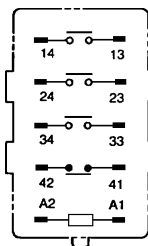

**G7J-2A2B-P(B)**

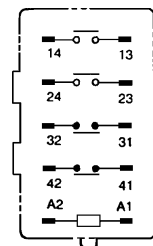

**■ APPROVALS**

UL 508 and 1950 (Recognized, File No. E41643)/CSA 22.2 No. 14 (Certified, File No. LR 35535)

Contact arrangement	Load type	Contact ratings
Normally Open	Resistive	25 A, 277 VAC, 30,000 cycles
		25 A, 30 VDC, 30,000
	General use	25 A, 120 VAC, 30,000 cycles
		25 A, 277 VAC, 30,000 cycles
		25 A, 240 VAC, 100,000 cycles
	Tungsten	1.5 kW, 120 VAC
	Motor load	1.5 HP, 120 VAC
		3 HP, 240/265/277 VAC
		3-phase, 3 hp, 240/265/277 VAC, 30,000 cycles
		3-phase, 5 hp, 240/ 265/277 VAC, 30,000 cycles
20 FLA/120 LRA, 120 VAC, 30,000 cycles		
17 FLA/102 LRA, 277 VAC, 30,000 cycles		
TV	TV-10, 120 VAC	
Normally Closed	Resistive	8 A, 277 VAC, 30,000 cycles
		8 A, 30 VDC, 30,000 cycles
	General use	8 A, 120 VAC, 30,000 cycles
		8 A, 277 VAC, 30,000 cycles

Note: 1. The rated values approved by each of the safety standards may be different from the performance characteristics individually defined in this catalog.  
 2. In the interest of product improvement, specifications are subject to change without notice.

**Precautions**

**■ HANDLING**

- To preserve performance, do not drop or otherwise subject the G7J relay to shock.
- The case is not designated to be removed during normal handling and operation. Doing so may affect performance.
- Use the power relay in a dry environment free from excessive dust, SO<sub>2</sub>, H<sub>2</sub>S, or organic gas.
- Do not allow a voltage greater than the maximum allowable coil voltage to be applied continuously.
- Do not use the relay outside of specified voltages and currents.
- Do not allow the ambient operation temperature to exceed the specified limit.

**■ INSTALLATION**

Although there are not specific limits on the installation site, it should be as dry and dust-free as possible.

PCB terminal-equipped relays weigh approximately 140 g. Be sure that the PCB is strong enough to support them. OMRON recommends dual-side through-hole PCBs to reduce solder cracking from heat stress.

**■ CLEANING PCB TERMINALS**

PCB terminals have semi-sealed construction which prevents flux from penetrating into the relay base housing due to capillary action. This type of relay cannot be immersed for cleaning.

**■ CONNECTION**

Refer to the diagram below when connecting a wire to the screw terminals on G7J.

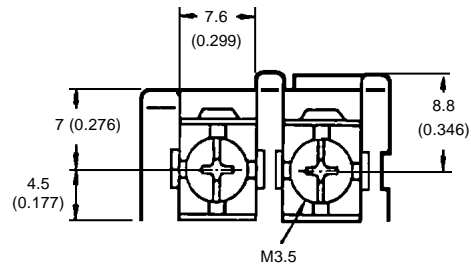

Allow suitable slack on leads when wiring, and do not subject the terminals to excessive force. Maximum tightening torque is 10 kgf-cm (72.50 ft-lbs).

---

**OMRON**

**OMRON ELECTRONICS, INC.**

One East Commerce Drive  
Schaumburg, IL 60173  
**1-800-55-OMRON**

**OMRON CANADA, INC.**

885 Milner Avenue  
Scarborough, Ontario M1B 5V8  
**416-286-6465**

Cat. No. GC RLY6

9/97

Specifications subject to change without notice.

Printed in the U.S.A.