

Sealed Basic Switch for Vehicles

D2FW-G

A Sealed Switch for Mechanical Detection in Automobiles and Industrial Vehicles (Conforming to IP67)

- Single-point mounting with an M4 screw.
- Incorporates a fixed leaf lever for tough environments.
- Molded lead wires are installed using lead-free connections for environmental conservation.

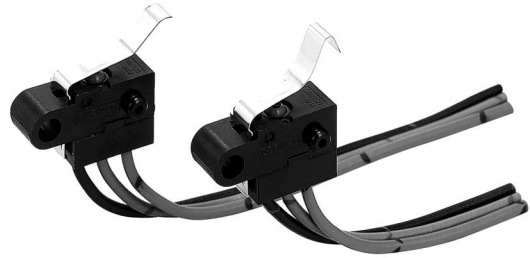

Ordering Information

■ Model Number Legend

D2FW-G M

1 2 3

1. Ratings/Contact Specifications

- 0: For micro load
- 2: For general load



2. Actuator

- 7 Leaf lever
- 8 Long leaf lever

3. Contact Form

- 1: SPDT
- 2: SPST-NC
- 3: SPST-NO

■ List of Models

Actuator	Rated load	Contact specifications (molded lead wires)	Model
Leaf lever 	0.1 A	SPDT	D2FW-G071M
		SPST-NC	D2FW-G072M
		SPST-NO	D2FW-G073M
	1 A	SPDT	D2FW-G271M
		SPST-NC	D2FW-G272M
		SPST-NO	D2FW-G273M
Long leaf lever 	0.1 A	SPDT	D2FW-G081M
		SPST-NC	D2FW-G082M
		SPST-NO	D2FW-G083M
	1 A	SPDT	D2FW-G281M
		SPST-NC	D2FW-G282M
		SPST-NO	D2FW-G283M

Note: The standard length of the lead wires (AVS0.5) is 30 cm.

Specifications

■ Ratings

Rated voltage	D2FW-G0□ (micro load models)	D2FW-G2□ (general-load models)
	Resistive load	
30 VDC	0.1 A	1 A

■ Characteristics

Item	D2FW-G0□	D2FW-G2□
Operating speed	1 to 500 mm/s	
Operating frequency	Mechanical: 120 operations/min max. Electrical: 20 operations/min max.	
Insulation resistance	100 MΩ min. (at 500 VDC)	
Contact resistance	150 mΩ max. (at 6 VDC, 0.1 A)	100 mΩ max. (at 6 VDC, 1 A)
Dielectric strength	600 VAC, 50/60 Hz for 1 min between terminals of the same polarity 1,500 VAC, 50/60 Hz for 1 min between current-carrying metal parts and ground, and between each terminal and non-current-carrying metal parts	
Vibration resistance	Malfunction: 10 to 55 Hz, 1.5-mm double amplitude, 1-ms max. contact opening	
Shock resistance	Destruction: 1,000 m/s ² max. Malfunction: 300 m/s ² max., 1-ms max. contact opening	
Life expectancy	Mechanical: 300,000 operations min.	
	Electrical: 100,000 operations min.	Electrical: 30,000 operations min.
Degree of protection	Conforms to IP67.	
Degree of protection against electric shock	Class 1	
Proof tracking index (PTI)	175	
Ambient operating temperature	-40°C to 85°C (at ambient humidity of 60% max.) (with no icing)	
Ambient operating humidity	95% max. (5°C to 35°C)	
Weight	Approx. 10.4 g (SPDT type)	

■ Contact Specifications

Item	D2FW-G0□ (micro load models)	D2FW-G2□ (general-load models)
Specification	Crossbar	
Material	Gold alloy	Silver alloy
Gap (standard value)	0.25 mm	
Minimum applicable load	1 mA at 5 VDC	100 mA at 5 VDC

■ Contact Form

SPDT

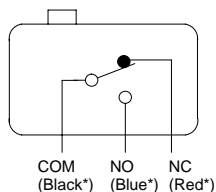

SPST-NC

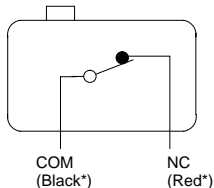

SPST-NO

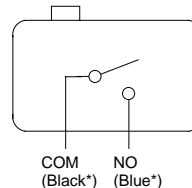

* The color in parentheses indicates the color of the lead wire.

Dimensions

■ Mounting Holes

Note: All units are in millimeters unless otherwise indicated.

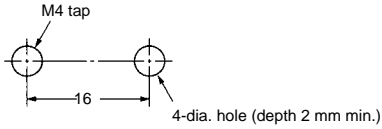

■ Dimensions and Operating Characteristics

- Note:**
1. All units are in millimeters unless otherwise indicated.
 2. The operating characteristics are for operation in the A direction (▼).

D2FW-G□7□M (Leaf Lever Models)

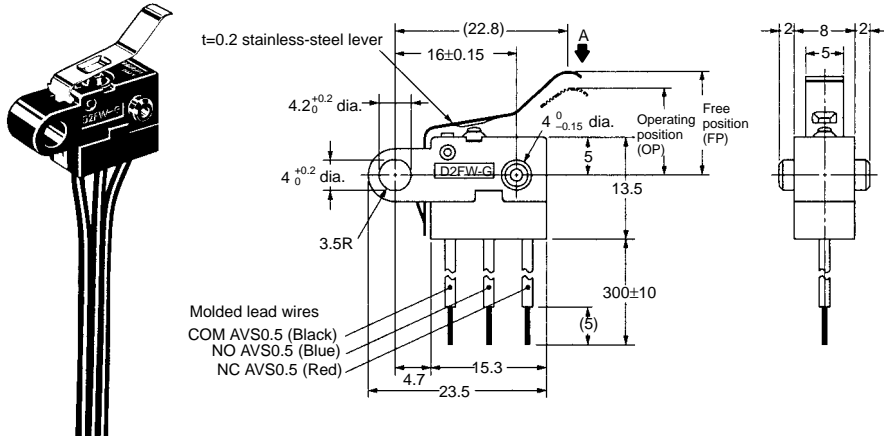

Model	Leaf Lever Models
	D2FW-G□7□M
OF max.	2.45 N
RF min.	0.29 N
OT min.	1.0 mm
MD max.	1.0 mm
FP max.	15.5 mm
OP	11.5±2 mm
TTP	(6.5 mm)

D2FW-G□8□M (Long Leaf Lever Models)

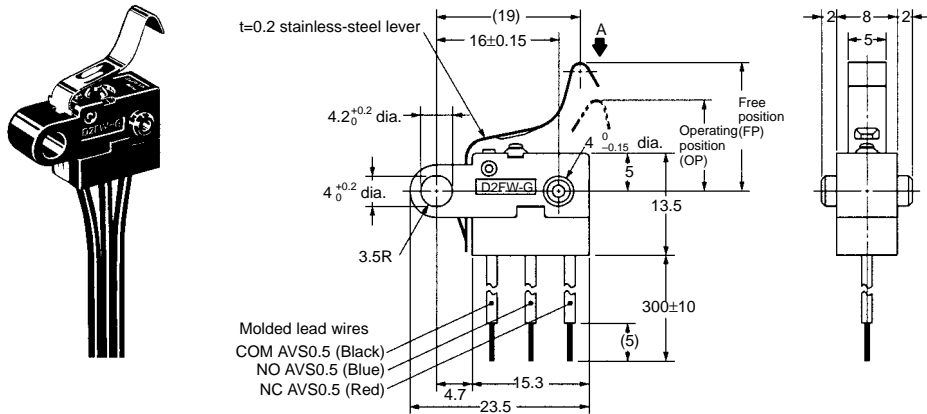

Model	Long Leaf Lever Models
	D2FW-G□8□M
OF	2.94 N
RF min.	0.59 N
OT min.	1.0 mm
MD max.	1.0 mm
FP max.	19 mm
OP	12±2 mm
TTP	(8.5 mm)

Precautions

Refer to pages 26 to 33 for common precautions.

■ Cautions

Use the Switch within the specified electrical ratings. Using the Switch outside of the rated values will not only shorten its service life but may cause heat generation or fire damage. When turning the power ON or OFF, use the rated voltage and current.

Degree of Protection

Do not use the Switch underwater. The Switch was tested and found to meet the conditions necessary to meet the following standard. The test checks for water intrusion after immersion for a specified time period. The test does not check for switching operation underwater.

IEC Publication 529, degree of protection IP67.

Protection Against Chemicals

Prevent the Switch from coming into contact with oil or chemicals. Otherwise, damage to or deterioration of Switch materials may result.

■ Correct Use

Mounting

Turn OFF the power supply before mounting or removing the Switch, wiring, or performing maintenance or inspection. Failure to do so may result in electric shock or burning.

Use M4 mounting screws with plane washers or spring washers to securely mount the Switch. Tighten the screws to a torque of 1.18 to 1.47 N•m (12 to 15 kgf•cm).

Mount the Switch onto a flat surface. Mounting on an uneven surface may cause deformation of the Switch, resulting in faulty operation or breakage in the housing.

Switch Mounting

When mounting the Switch, do not apply force to the actuator in any direction other than its operating direction.

Operation

Make sure that the switching object is perfectly separated from the actuator when the switch is not operated and the actuator is pressed appropriately by the switching object when the switch is operated. The switching object must not move beyond its operational limit position, otherwise the Switch may be damaged.

Install the switching object so that its moving direction is the same as that of the actuator.

Using Micro Loads

Using a model for ordinary loads to open or close the contact of a micro load circuit may result in faulty contact. Use models that operate in the following range. However, even when using micro load models within the operating range shown below, if inrush current occurs when the contact is opened or closed, it may increase contact wear and so decrease life expectancy. Therefore, insert a contact protection circuit where necessary.

The minimum applicable load is the N-level reference value. This value indicates the malfunction reference level for the reliability level of 60% ($\lambda 60$). The equation, $\lambda 60 = 0.5 \times 10^{-6}/\text{operations}$ indicates that the estimated malfunction rate is less than 1/2,000,000 operations with a reliability level of 60%.

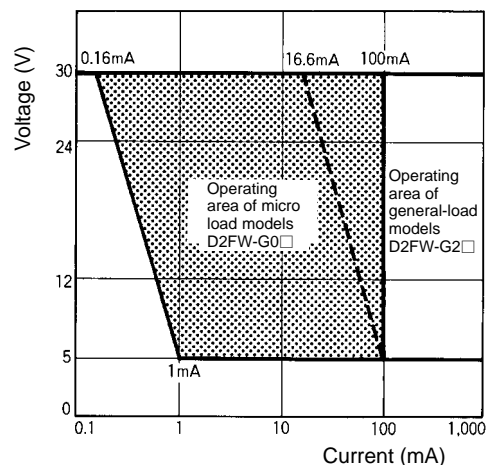

ALL DIMENSIONS SHOWN ARE IN MILLIMETERS.

To convert millimeters into inches, multiply by 0.03937. To convert grams into ounces, multiply by 0.03527.

Cat. No. B104-E1-01B