



# TECHNICAL INFORMATION SHEET

## NAP-67A Catalytic Gas Sensor, For Propane / Butane / LPG

Nemoto Sensor  
Engineering Co., Ltd.  
4-10-9, Takaido-higashi,  
Suginami-ku, Tokyo,  
JAPAN

### General Description

The Nemoto NAP-67A is a new, improved low cost catalytic flammable gas sensor. Closely related to the very popular NAP-66A sensor, the NAP-67A uses exactly the same sensing elements, but the enclosure in which they are mounted employs a nickel plated brass mounting cap and a phenolic resin header, instead of the Nylon 66 material used in the NAP-66A. As a result, the sensor exhibits an increased sensitivity output and an increase in useful temperature range, whilst being very slightly larger in dimensions, compared to the NAP-66A.

The widened temperature range of the NAP-67A makes it particularly suitable for applications such as recreational vehicles, caravans and marine applications where a wide temperature range is required. The mechanical construction and technical performance of this sensor makes it also suitable for a wide variety of Industrial and commercial gas detection applications.

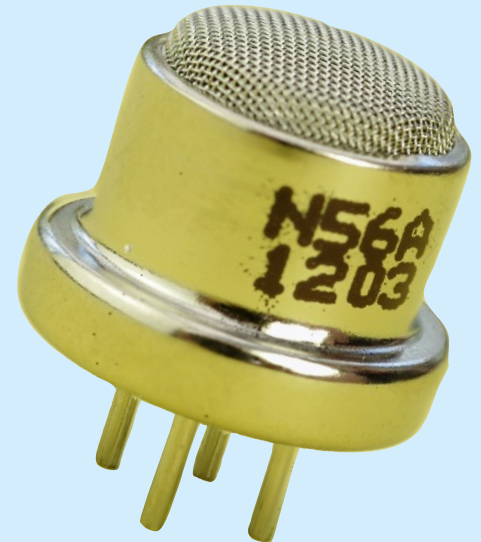

- **Monitors flammability directly**
- **Unaffected by humidity**
- **Very low long term drift**
- **Poison resistant**
- **Single header design**
- **Superb temperature stability**
- **Shock Resistant**
- **Linear output to 50% LEL**

### Specifications:

Detectable Gas	Propane / Butane / LPG
(Note : NOT suitable for monitoring Methane)	
Recommended Voltage:	2.0V +/- 0.2V
Current Drawn:	160 +/- 10mA
Zero Offset:	0mV +/- 35mV
Typical Signal Sensitivity:	20 mV for 2000ppm C <sub>4</sub> H <sub>10</sub>
Range:	0-50% LEL
Repeatability:	+/- 0.5mV
<b>Maximum Long Term Drift:</b>	
Span:	< +/- 2% Signal / Month
Zero:	< +/- 5 mV / Month
Response Time:	T <sub>90</sub> : <10 sec
Temperature Range:	-40°C to +70°C
Humidity:	0-95%RH, non-condensing
Linearity:	Effectively Linear to 60%LEL
Expected Lifetime	5 years

Test data on drift, poisoning, temperature performance, linearity are available on the Characterisation Document.

Nemoto has a policy of continuous development and improvement of its products. As such the specification for the device outlined in the data sheet may be changed without notice

nap-67a.ppp, issue 2, Dec 2012

## Dimensions, Materials and Recommended Circuit

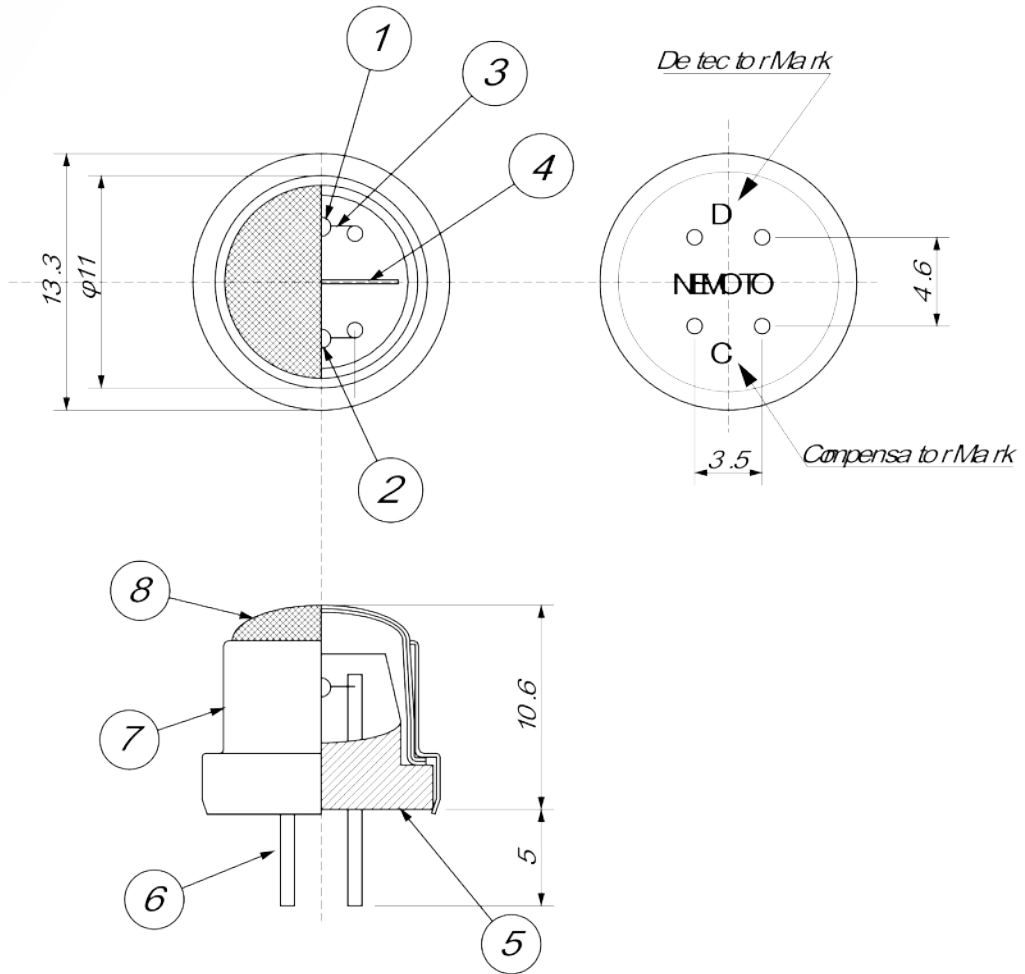

8 Mesh	SUS316#100	Double
7 Strainer	Brass with Ni coating	t=0.2
6 Pin	Ni	φ0.8
5 Base mount	Phenol	—
4 Separator	SUS304	t=0.2
3 Coil	Pt	φ0.03
2 Compensator	—	—
1 Detector	—	—
No Parts	Materials	Remarks

Test data on drift, poisoning, temperature performance, linearity are available on the Characterisation Document.

Nemoto has a policy of continuous development and improvement of its products. As such the specification for the device outlined in the data sheet may be changed without notice

**Nap-67a.ppp, issue 2, Dec 2012**