

GOT TRAFFIC? ...WE'VE GOT YOU COVERED!

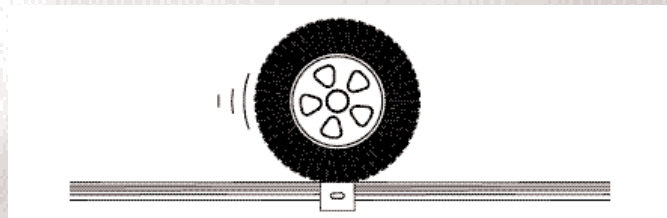

Roadtrax® BL
Piezoelectric Axle Sensor

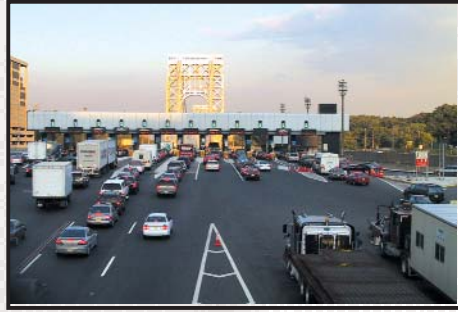
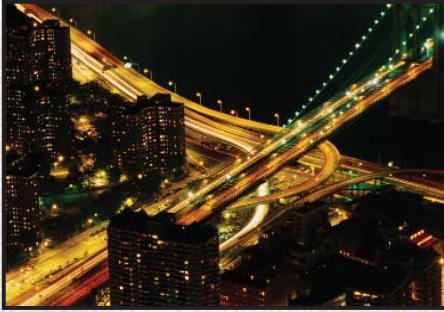

Dear Traffic Professional,

Thank you for your interest in Roadtrax[®] BL Piezoelectric Traffic Sensors for weigh in motion (WIM), vehicle classification and counting, speed detection, red light cameras, and parking area control applications.

Enclosed are product specifications and installation instructions. This unique sensor is only 1/16 inch thick and 1/4 inch wide (1.5mm x 6.5mm), but will provide 500 mV for a car and is installed in a 3/4 inch wide by 1 inch deep (19mm x 25mm) slot in the road. The Roadtrax BL rejects road noise 10:1 and, due to its flat design, reduces ghost axles, giving your electronics a clean, easy to read signal that translates into more accurate classification, speed, and WIM data.

Measurement Specialties will work closely with you to ensure that your needs are met, and will assist you in preparing for sensor installation. An installation video is available on CD ROM for your convenience.

Please call me directly if you have any questions, for more information, or for a quote on your specific traffic sensing requirements.

Sincerely,

A handwritten signature in black ink that reads "Donald Halvorsen". The signature is fluid and cursive, with a large initial "D".

Donald L. Halvorsen
Director, Traffic Sensors

Measurement Specialties, Inc.
1000 Lucas Way
Hampton, VA 23666
Phone 757-766-1500
Fax 757-766-4279
e-mail: piezo@meas-spec.com
www.meas-spec.com

Sensor Products Division - Europe
Germany
Tel: +49 6074 862 822
Fax: +49 6074 862 823
e-mail: rhbrown@t-online.de

Product Description

The Roadtrax BL Traffic Sensor is designed for permanent or temporary installation into or onto the road surface for the collection of traffic data. The unique construction of the sensor allows direct installation into the road in a flexible format so that it can conform to the profile of the road. The flat construction of the sensor gives an inherent rejection of road noise due to road bending, adjacent lanes, and bow waves of approaching vehicles. The small cut in the road minimizes the damage done to the road, speeds up the installation and reduces the amount of grout used for the installation. The Roadtrax BL sensor is available both as a Class I sensor for the highest level of uniformity needed for Weigh in Motion applications and as a Class II sensor which is more cost effective for Counting, Classifying, High Speed Toll Booths, Speed Detection, and Red Light Cameras.

- Uniform, high amplitude piezoelectric output compatible with existing counters and classifiers on the market.
- Excellent Signal to Noise Ratio which has an inherent 10:1 rejection of road noise due to road bending, adjacent lanes and bow waves of approaching vehicles.
- Easy installation in a 3/4 x 1 (19 x 25mm) slot, which minimizes the disturbance of the road, decreases the depth of the road cut, and minimizes the amount of grout needed.
- Flexible sensor - conforms to any road profile while maintaining a uniform distance to the road surface.
- The final installation is flush with the road surface - snowplows will not damage the sensor.
- Durable enough to withstand normal installation handling and hundreds of millions ESAL's.
- All sensors are 100% tested and certified for performance as a complete sensor prior to shipment.
- Custom Passive Signal Cable with High Density Poly Ethylene Jacket which is rated for direct burial and resists nicks and cuts.

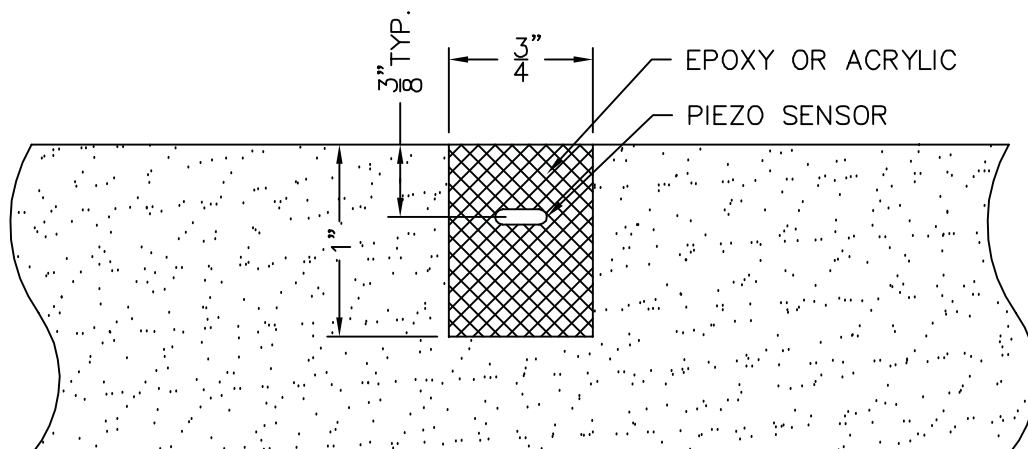

Permanent in the Road Installation

Performance Characteristics

Output Uniformity	±20% for Class II (Classification) ±7% for Class I (Weigh in Motion)
Operating Temperature Range	- 40 to 160°F (-40 to 70°C)
Temperature Sensitivity	0.2%/°F typ, dependent on the grout used
Typical Output Level	A wheel load of 400 pounds will produce a minimum output signal of 250 mV, at 70°F and 55 mph for a proper installation
Passive Signal Cable	RG 58C/U with a High Density Polyethylene Outer jacket that is rated for direct burial; 3/16 (4.75mm) OD
Product Life	40 Million ESAL's; dependent on the installation
Capacitance	See Chart
Weight	See Chart
Insulation Resistance	>500 MΩ
Packaging	All sensors are packaged two per each 24 x20 x3 (600x550x75mm) corrugated cardboard box
Installation Brackets	Included. One bracket is used every 6 (150mm)

Specifications¹

The Measurement Specialties BL Traffic sensor has the following specifications:

1. Center Core: 16 gauge, flat, braided, silver plated copper wire.
2. Piezoelectric Material: Spiral-wrapped PVDF Piezoelectric film
3. Outer Sheath: 0.016 thick brass, CDA-260, ASTM B587-88
4. Final Dimensions: 0.260 wide x 0.063 thick; 0.005
5. Insulation resistance between core and shield: > 500 MΩ.
6. Piezoelectric Coefficient: 34 pC/N - nominal.
7. Passive Signal Cable: RG 58 type with a underground/direct burial rated outer jacket. The OD of the cable is 0.187 (4.75mm). The nominal capacitance of the cable is 27 pF/ft (89pF/m).
8. Sensors are packaged 2 per box. The box size is 24 x20 x3 (600x550x75mm).
9. Two sizes of installation brackets are included with the sensors, 3/4 (small) brackets and 1 (large) brackets. There is one small and one large bracket per 6 (150mm) of sensor length.

Notes:

1. Although Measurement Specialties Inc. makes every effort to ensure the accuracy of the specifications at the time of publication, specifications for this product are subject to change without notice. Contact Measurement Specialties for the most current information at (757) 766-4474 or piezo@meas-spec.com.

Sensor Length	Sensor Classification ¹	Capacitance with 100' cable ²	Weight ³ pounds (kg)	Visible Brass Length	Installed Length ⁴	Part Number ⁵
6' (1.82m)	Class II	4.00 nF ≤ C ≤ 10.00 nF	2.75 (1.25)	70 (1.78m)	76 (1.93m)	0-1005333-Y
8' (2.42m)	Class II	5.50 nF ≤ C ≤ 11.50 nF	2.80 (1.27)	94 (2.38m)	100 (2.54m)	1-1005333-Y
9' (2.73m)	Class II	6.25 nF ≤ C ≤ 12.25 nF	2.85 (1.30)	106 (2.69m)	112 (2.85m)	2-1005333-Y
10' (3.03m)	Class II	7.00 nF ≤ C ≤ 13.00 nF	2.90 (1.32)	118 (3.00m)	124 (3.15m)	3-1005333-Y
11' (3.33m)	Class II	7.75 nF ≤ C ≤ 13.75 nF	2.95 (1.34)	130 (3.30m)	136 (3.45m)	4-1005333-Y
12' (3.64m)	Class II	8.50 nF ≤ C ≤ 14.50 nF	3.00 (1.36)	139 (3.53m)	145 (3.68m)	5-1005333-Y
13' (3.94m)	Class II	9.25 nF ≤ C ≤ 15.25 nF	3.05 (1.39)	154 (3.91m)	160 (4.06m)	6-1005333-Y
6' (1.82m)	Class I (WIM)	4.00 nF ≤ C ≤ 10.00 nF	2.75 (1.25)	70 (1.78m)	76 (1.93m)	1-1005438-Y
8' (2.42m)	Class I (WIM)	5.50 nF ≤ C ≤ 11.50 nF	2.80 (1.27)	94 (2.38m)	100 (2.54m)	2-1005438-Y
9' (2.73m)	Class I (WIM)	6.25 nF ≤ C ≤ 12.25 nF	2.85 (1.30)	106 (2.69m)	112 (2.85m)	3-1005438-Y
10' (3.03m)	Class I (WIM)	7.00 nF ≤ C ≤ 13.00 nF	2.90 (1.32)	118 (3.00m)	124 (3.15m)	4-1005438-Y
11' (3.33m)	Class I (WIM)	7.75 nF ≤ C ≤ 13.75 nF	2.95 (1.34)	130 (3.30m)	136 (3.45m)	5-1005438-Y
12' (3.64m)	Class I (WIM)	8.50 nF ≤ C ≤ 14.50 nF	3.00 (1.36)	139 (3.53m)	145 (3.68m)	6-1005438-Y
13' (3.94m)	Class I (WIM)	9.25 nF ≤ C ≤ 15.25 nF	3.05 (1.39)	154 (3.91m)	160 (4.06m)	7-1005438-Y
2.0m (6'7)	Class II	4.94 nF ≤ C ≤ 10.94 nF	2.75 (1.25)	1.98 m (78)	2.14 m (84)	1-1005528-Z
2.5m (8'3)	Class II	6.17 nF ≤ C ≤ 12.17 nF	2.85 (1.30)	2.48 m (98)	2.64 m (104)	2-1005528-Z
3.0m (9'11)	Class II	7.40 nF ≤ C ≤ 13.40 nF	2.95 (1.35)	2.98 m (117)	3.14 m (123)	3-1005528-Z
3.5m (11'6)	Class II	8.63 nF ≤ C ≤ 14.63 nF	3.05 (1.40)	3.48 m (137)	3.64 m (143)	4-1005528-Z
4.0m (13'2)	Class II	9.87 nF ≤ C ≤ 15.87 nF	3.15 (1.45)	3.98 m (157)	4.14 m (163)	5-1005528-Z
4.5m (14'10)	Class II	11.09 nF ≤ C ≤ 17.09 nF	3.25 (1.50)	4.48 m (177)	4.64 m (183)	6-1005528-Z
5.0m (16'6)	Class II	12.32 nF ≤ C ≤ 18.32 nF	3.35 (1.55)	4.98 m (196)	5.14 m (202)	7-1005528-Z
5.5m (18'2)	Class II	13.55 nF ≤ C ≤ 19.55 nF	3.45 (1.60)	5.48 m (216)	5.64 m (222)	8-1005528-Z
2.0m (6'7)	Class I (WIM)	4.94 nF ≤ C ≤ 10.94 nF	2.75 (1.25)	1.98 m (78)	2.14 m (84)	1-1005527-Z
2.5m (8'3)	Class I (WIM)	6.17 nF ≤ C ≤ 12.17 nF	2.85 (1.30)	2.48 m (98)	2.64 m (104)	2-1005527-Z
3.0m (9'11)	Class I (WIM)	7.40 nF ≤ C ≤ 13.40 nF	2.95 (1.35)	2.98 m (117)	3.14 m (123)	3-1005527-Z
3.5m (11'6)	Class I (WIM)	8.63 nF ≤ C ≤ 14.63 nF	3.05 (1.40)	3.48 m (137)	3.64 m (143)	4-1005527-Z
4.0m (13'2)	Class I (WIM)	9.87 nF ≤ C ≤ 15.87 nF	3.15 (1.45)	3.98 m (157)	4.14 m (163)	5-1005527-Z
4.5m (14'10)	Class I (WIM)	11.09 nF ≤ C ≤ 17.09 nF	3.25 (1.50)	4.48 m (177)	4.64 m (183)	6-1005527-Z
5.0m (16'6)	Class I (WIM)	12.32 nF ≤ C ≤ 18.32 nF	3.35 (1.55)	4.98 m (196)	5.14 m (202)	7-1005527-Z
5.5m (18'2)	Class I (WIM)	13.55 nF ≤ C ≤ 19.55 nF	3.45 (1.60)	5.48 m (216)	5.64 m (222)	8-1005527-Z

1. Class II sensors have a uniformity of ±20% and are typically used for Classification purposes. Class I sensors have a uniformity of ±7% and are typically used for Weigh in Motion applications.
2. Additional cable has a capacitance of 27 pF/ft (89 pF/m) or 2.7 nF/100' (2.2 nF/25m). Provided with each sensor is a test certificate with the actual tested value for the sensor. Field tests should be within ±20% of these values, at room temperature (70F or 23C).
3. All sensors are packaged 2 per box. The box weighs 1.5 lbs (0.7 kg).
4. This length refers to the installed length of the sensor. This is the minimum lane width for the installed sensor.
5. The suffix refers to the cable length. Cable lengths for -Y are as follows: -1 @ 100', -2 @ 150', -3 @ 200', -4 @ 250', -5 @ 300'. Cable lengths for the -Z are as follows: -1 @ 35m, -2 @ 50m, -3 @ 75M, and -4 @ 100m.

BL Piezoelectric Traffic Sensor Installation Instructions

- 1) Ensure that the road is safely closed, as per local regulations.
- 2) Using pavement crayons, paint, tape measure and cord, carefully mark the layout of the sensor installation. Ensure sensors are emplaced exactly perpendicular to the flow of traffic and that all lines are straight. Verify that the passive cable length is enough to reach the cabinet. **DO NOT SPLICE CABLE IF IT IS TOO SHORT.** Typical WIM/Classification site layout with 11' (3.5 m) sensors is shown below.

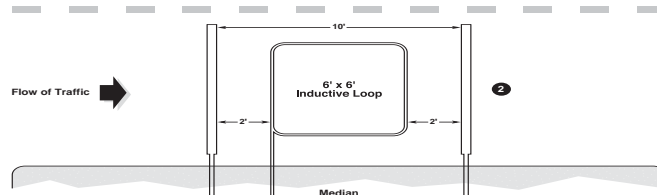

- 3) Using a 3/4" (20 mm) Diamond Blade, wet cut slot for sensor. Slot must be 3/4" (20 mm) wide ($\pm 1/16"$ or ± 2 mm) by 1" (25 mm) minimum deep. Cut slot 8" (200 mm) longer than sensor length (including lead attachment). Drop blade an extra 1/2" (12 mm) down on both ends. Repeat for all sensors.

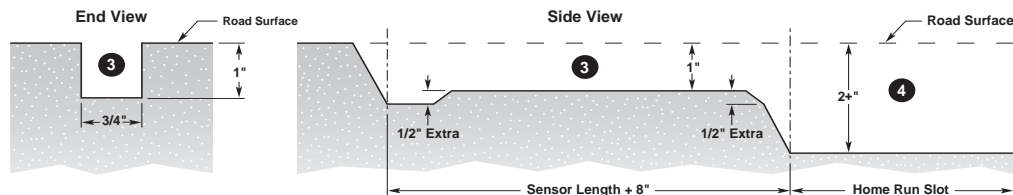

- 4) Cut home run slots for BL sensors. Center the home run slot on the sensor slot. Home run slots are typically cut the depth of the loop home run slots. The minimum width of the slot needs to be 1/4" (6 mm). Cut it wider if you are using conduit or tubing.
- 5) Cut all inductive loops sets (if applicable) Note: If inductive loops and home run slots are being dry cut, dry cut these slots and clean the area before wet cutting the BL sensor slots.
- 6) Power wash and sweep all slots. All slots must be very clean.
- 7) Dry all slots with compressed air. All slots and the pavement 1' (300 mm) on either side must be completely dry.
- 8) Place duct tape along length of both sides of the sensor slot. Tape must be 1/8" (3 mm) away from the slot. Repeat for all sensors.

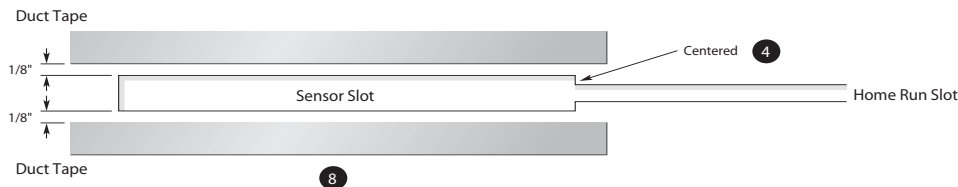

- 9) Remove BL sensor from box. Visually inspect sensor to ensure it is straight without any twists or curls. Check passive cable for bare wire. Check lead attachment for cracks or gaps. Look at data sheet to ensure the correct sensor is being installed, Class I versus Class II. Again, verify that there is sufficient passive cable to reach the cabinet.
- 10) Connect sensor up to LCR Meter. Test capacitance and dissipation factor. Test the resistance on the 20M setting. Capacitance and dissipation should be within $\pm 20\%$ of the enclosed data sheet. Resistance should be infinite. Record all results on the data sheet.
- 11) Place sensor on tape next to the slot. From this point forward, handle the sensor with latex (or equivalent) gloves.

- 12) Clean sensor with steel wool or emery pad. Wipe down with alcohol and clean lint-free cloth.
- 13) Place installation brackets on sensor every 6" (150 mm) for the length of the sensor, use the 3/4" (20 mm) (small) brackets
- 14) Bend the end of the sensor downward at a 30° angle. Bend the lead attachment end down at a 15° angle and then 15° back up until level (forming a lazy Z).

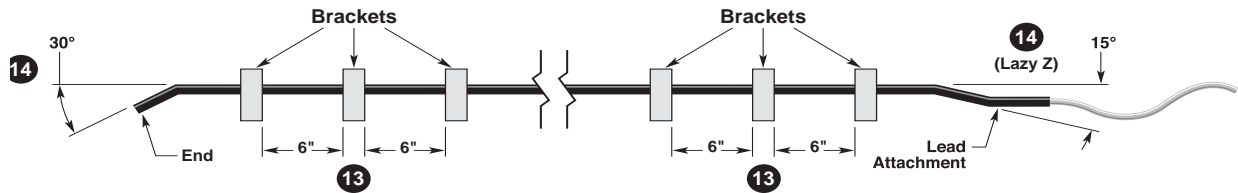

- 15) Emplace sensor in the slot in the road. The end of the sensor should be at least 2" (50 mm) from the end of the slot, and the tip should not touch the bottom of the slot. The lead attachment should also not touch the bottom or the sides of the slot.

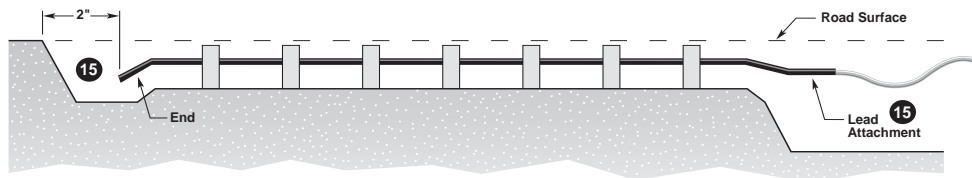

- 16) If any of the 3/4" (20 mm) (small) brackets do not fit snugly against the sides of the slot or are loose, replace with a 1" (25 mm) (large) bracket and repeat step 15.

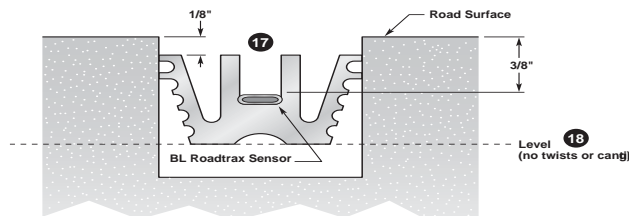

- 17) Starting at the lead attachment end, use the installation depth gauge to position the sensor so that it is 3/8" (9mm) below the surface of the road by pressing the depth gauge against the top of the sensor. At this point, the installation bracket is 1/8" (3mm) below the surface of the road.

- 18) Visually inspect the length of the sensor to ensure it is at uniform depth along its length and it is level (not twisted, canted or bent).

- 19) Run the passive wire the length of the home run slot. 3" (75 mm) from the lead attachment, place backer rod under and over passive cable (inside the slot). This will keep the grout from running out into the deeper home run slot. If the passive cable is put in a conduit, also allow 3" (75 mm) between the lead attachment and the beginning of the conduit.

- 20) Repeat steps 9-18 for all BL sensors to be installed.

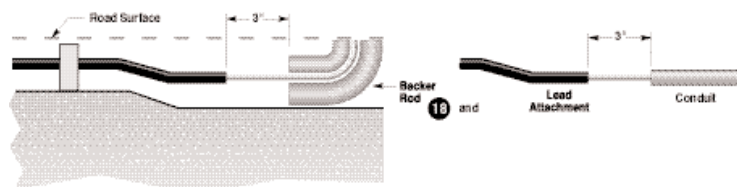

- 21) Emplace all inductive loops to site specifications (if applicable).
- 22) Using low speed mixing drill (450 rpm) and a mixing paddle, premix the grout for 2 min or until smooth.
- 23) Add hardener to grout and mix according to manufacturer's instructions.

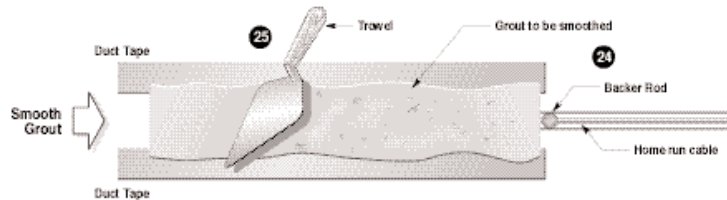

- 24) Immediately pour grout into slot using a small bead. Using a small bead allows the installer to watch the grout flow under the sensor, eliminating air pockets. Start at the end and pour towards the lead attachment. Repeat until slot is completely full of grout. **DO NOT FILL SLOT IN ONE PASS.**
- 25) Using putty knife or trowel, lightly spread (feather) the grout smooth along the length of the slot. Resin should be slightly higher than tape as it will shrink while curing.
- 26) Remove tape as soon as grout begins to set (2-5 min, depending on grout type and ambient temperature).

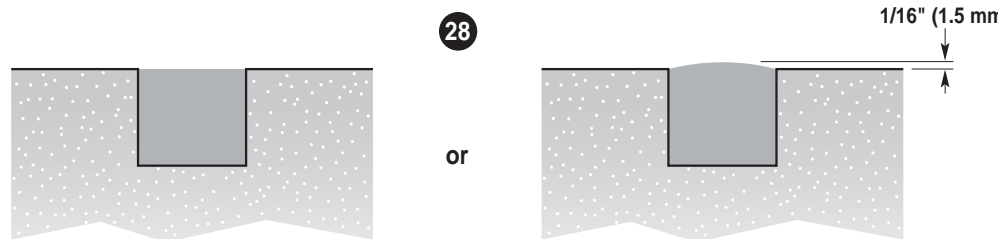

- 27) Remove backer rod from the slot. Fill in home run cable and inductive loops with loop sealant.
- 28) Once grout is cured, use an angle grinder or a belt sander to grind/sand the top of the grout flush with the surface.
- 29) Wait allotted period to allow loop sealant and grout to fully cure (45 - 60 min) and then open the lane to traffic.
- 30) Hook up oscilloscope to sensors and view wave forms as vehicles pass. Ensure signal is clear without noise.

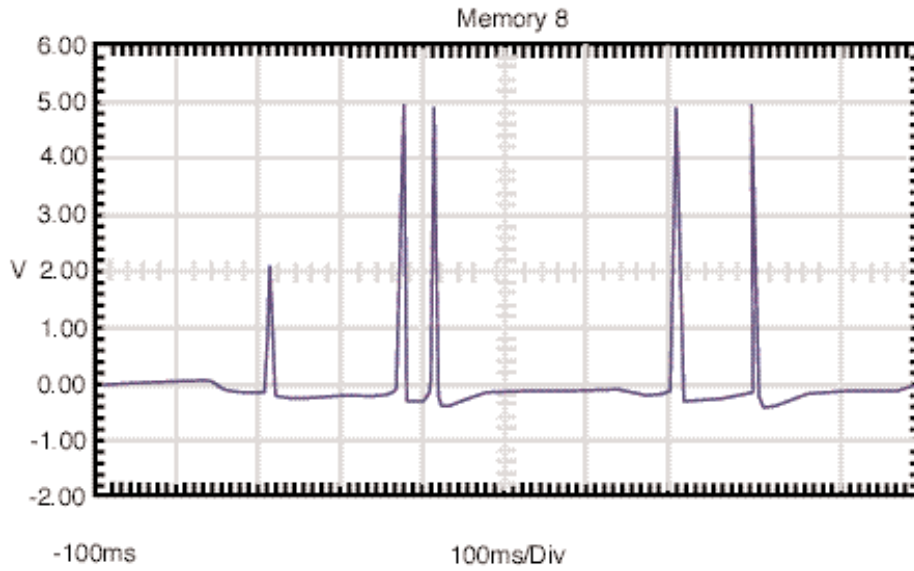

Datablock	
Name	= Memory 8
Date	= 5/20/97
Time	= 8:55:43 PM
Y Scale	= 1.00 V/Div
Y At 50%	= 1.00 V
X Scale	= 100 ms/Div
X At 0%	= -100 ms
X Size	= 250 (256)
Maximum	= 5.60 V
Minimum	= -0.44V

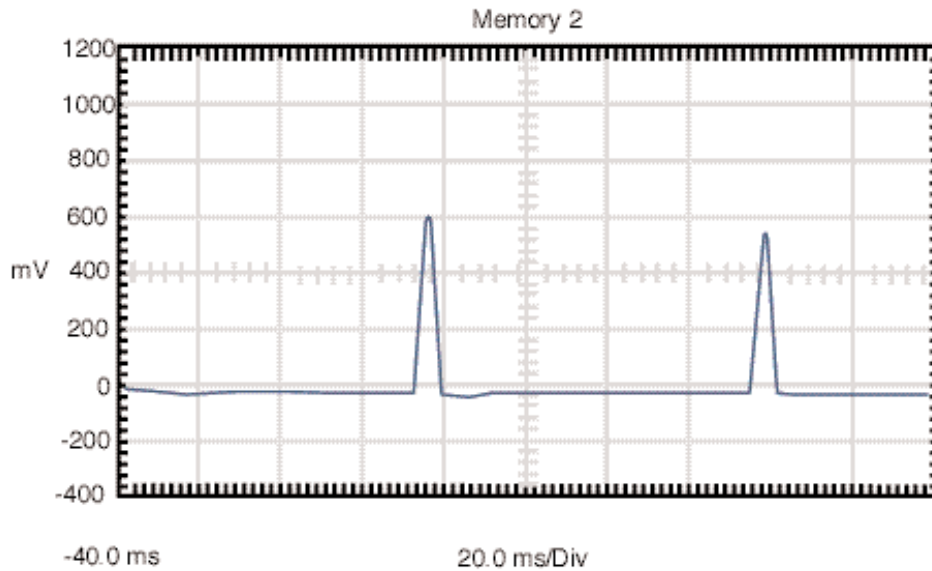

Datablock	
Name	= Memory 2
Date	= 6/14/97
Time	= 9:13:37 AM
Y Scale	= 200 mV/Div
Y At 50%	= 400 mV
X Scale	= 20.0 ms/Div
X At 0%	= -40.0 ms
X Size	= 250 (256)
Maximum	= 608 mV
Minimum	= -40 mV

Required/recommended tools and materials

- Measurement Specialties BL Sensors with installation brackets. Sensors should be ordered with sufficient passive cable to reach the control cabinet.
- Installation instruction. Read these instructions prior to the installation. There may need to be some adaptation of these instructions based on local conditions.
- Sensor support brackets. These are shipped in the box with the sensors.
- Installation Depth Gauge. These are shipped in the box with each sensor.
- Installation encapsulation. See Recommended materials under frequently asked questions. Approximately 1/2 to 1 gallon (1.5 to 3 liters) of material is needed per sensor. The slot must be carefully cut in order to ensure that it is not too deep; otherwise excessive material is used. Read, understand and follow the directions supplied by the manufacturer of the installation encapsulation. Adhere to the temperature limits imposed on the material to ensure adequate drying time is available. Follow all recommended safety precautions.
- Loop sealant material, to cover the home run cables. Amount used will depend on the length and width of the homerun cuts. **DO NOT USE HOT TAR.**
- ★ Thin wall tubing for homerun cables. Minimum 3/8 (9mm) ID, flexible tubing. Materials for this tubing are typically flexible PVC or polyethylene. Sufficient quantity for all homeruns from the end of the sensors to the cabinet.
- ★ PVC pipe, 2-3 (50-75mm) dia. For use as conduit for any underground runs from junction boxes to cabinets.
- ★ PVC solvent and joints - as needed for any splices in the pipes.
- Wet cutting pavement saw. A self-propelled saw of at least 35 hp, fitted with a 14 (350mm) or larger blade. This saw must be capable of cutting a 3/4 wide x 1 deep (19mm wide x 19-25mm deep) cut in a single pass.
- Diamond Blades for the saw. Appropriate type for the pavement being cut. The Piezo sensor needs a cut 11/16 to 13/16 (19mm ± 1mm) wide, 1 (25mm) deep slot cut in the road in a single pass. If a single blade is not available, multiple blades can be put together to form a dado blade. A 3/8 (9mm) and a 1/4 (6mm) blade, with a 1/16 (2mm) spacer between them performs very well. Additional blade widths are necessary for cutting the slots for the tubing for the home run cables.
- Large capacity air compressor (at least 150 CFM) with hose and nozzle - for blowing out the slot and drying the area after the cut.
- Trenching equipment as required for burying the conduit to the control cabinet.
- Power washer or high pressure water hose - for washing out the slot.
- Water - for saw and for washing out the slot
- Broom - Street broom type with stiff bristles for general cleanup.
- Slow speed electric drill with mixing paddle
- Additional mixing blade if a two part loop sealant is used. There should not be cross contamination of the grout used for the piezo and the loop sealant material.
- Wire Brush and/or bristle brush - for cleaning out the slot after cutting and during washing.
- 3 or 4 (75-100mm) putty knife for use with the grout
- Small pointed trowel for putting the grout into the slot.
- Wire Strippers. Knife type blade strippers, such as Ideal Tools Stripmasters should be used due to the toughness of the HDPE jacket on the sensor homerun cable.
- Cleaning Materials for hands and equipment. The citrus hand cleaner works well. Include lots of paper towels.
- Angle Grinder with appropriate grinding wheel or belt sander for smoothing out the grout after the installation.
- Hammer and masonry chisels. May be required for chipping corners, etc.
- Disposable gloves (rubber dishwashing gloves work much better than the latex or plastic gloves)
- 2 (50mm) duct tape. Enough for twice the length of all the sensors. Used to keep excessive grout off the road next to the slot during the installation.
- Plumbers putty or duct seal to form dams at the end of the grout
- Straight edge
- Tape measure - at least 20' (6m) long
- Pavement crayons
- Chalk line
- Pavement paint
- 1/8 (3mm) diameter cord or rope for use in laying out the lines
- LCR Meter, such as a BK 875A, to check and measure Capacitance and Resistance of the sensors before and after installation.
- ★ Oscilloscope. Although not essential, it is the only instrument that will give a complete verification that the sensors are fully functioning when the installation is complete. If reliable power is not available on the site, a battery operated oscilloscope should be used, such as the Fluke Scopemeter.
- Generator if electrical power is not available on site. Verify the electrical load of the tools being used compared to the capacity of the generator.
- Appropriate traffic control, as required by local regulations and appropriate safety guidelines
- Safety equipment required for workers. Safety helmets, safety glasses, reflective vests, etc, as required.
- ★ Not included in this list are materials required for inductive loops (if used), control cabinets, junction boxes, and other off the road work.

■ Required Equipment

★ Recommended Equipment

Important Notes and Hints:

- The quality of the road will affect the quality of the data. The roads should conform to ASTM specifications for Weigh in Motion applications.
- Diamond blades should be used on the road saw. The tolerance for the cut is 11/16 to 13/16. A 3/4 diamond blade is recommended for cutting the slot. Do not try to do two independent cuts as it is very difficult to achieve this level of accuracy.
- Wet cutting is preferred to dry cutting. The dry cutting forces particles into the sidewalls of the slot which are very difficult to thoroughly clean. This residue will diminish the adhesion of the adhesive to the road, potentially causing the premature failure of the sensor.
- The passive cable length should not exceed 300' without consulting the manufacture. It is **STRONGLY** recommended that the sensors be ordered with sufficient cable to avoid splices. If splices are needed, only similar grade of RG-58 cable should be used, the splices must be soldered, and an approved splice kit used to waterproof the splice. Measurement Specialties is not responsible for any problems arising from splicing the cable.
- Disposable gloves must be worn when working with the clean sensor and encapsulation material. Appropriate precautions should be taken, according to the encapsulation material manufacturer's instructions. Ensure you read and follow all safety instructions.
- Adequate traffic control is essential. Do not put any of your workers at risk.
- Ensure that the sensor is placed in the correct location on the road. Six foot sensors should be positioned in a wheel path, **NOT** in the center of the lane.
- Care should be taken when mixing the encapsulation material to minimize the amount of trapped air in the material. Do not lift the mixing paddle out of the encapsulation material while the mixing head is spinning. Stop the blade and then use a stirring paddle to scrape the edges of the can.
- If heaters are needed to speed the curing process for the grout, extreme care should be taken to ensure that the sensors are not destroyed. The maximum temperature that the sensors can withstand is 170°F! An A-Frame should be constructed out of metal or plywood, and placed over the sensor. Warm air from a torpedo heater should be blown in horizontally into the A-Frame, but **NEVER** aimed directly at the sensor. The air temperature at the sensor location should not be higher than what can be tolerated by your hand for 20-30 seconds. If it is hotter than this, the sensor will lose its piezo activity and will not function.
- Once the sensor is installed and the grout is cured, it is recommended that any excessive grout be ground off, using an angle grinder or belt sander. The best installation has the grout flush with the road surface to minimize any chance of the tires bridging over the sensor.
- Thin walled plastic tubing may be used to contain the home run cable. In the unlikely event that the sensor needs to be replaced, the passive cable can then be pulled through the tubing, thereby eliminating the need for recutting the home run slot.
- Read all of the directions carefully and completely prior to the installation. Ensure that you have all of the required equipment available. If there are any questions on the installation, call Measurement Specialties and we will be happy to 'walk' you through the procedures.

Sensor Testing:

The piezoelectric sensors should be tested prior to and after installation. Because of the high costs of installation compared to the cost of the sensor, it is imperative that the sensors be checked out prior to putting them into the road to determine if any damage has been done to the sensor during shipping and handling. The following tests should be done prior to installation:

Equipment needed: LCR meter, such as a BK Instruments 875A or 875B.

1. **Capacitance:** Measure the capacitance of the sensor with the attached lead in cable. This should be 20% of the sensor's data sheet included in the box. The meter should typically be set on a 20nF range. The red probe should be connected to the center electrode of the cable and the Black probe to the outer braid. Make sure that you hands are not holding across the two connections.
2. **Resistance:** Measure the resistance across the sensor. The meter should be set on the 20M Ω setting. The meter should read in excess of 20M Ω , which is typically displayed with a '1'.

Testing after installation:

Once the sensor is installed and the grout has cured, retest the sensor according to the instructions above. In addition, it is recommended that an oscilloscope be connected to the sensor and typical waveforms be collected for a truck and a car. These should then be printed out and saved for permanent records. The output of the sensor will depend on the type of the installation, sensor length , cable length and epoxies used for the installation. Typical settings for the scope would be 200 mV/div for a voltage setting and 50 msec/div for a time setting. The trigger should be set at about 50 mV for a positive going signal.

Sensor Maintenance:

Like any piece of equipment, regular maintenance should be done to the piezoelectric sensors in order to maintain them for a long service life. The sensors should be inspected on a bi-annual basis, and any cracks in the road or in the sensor encapsulation should be filled. A low viscosity loop sealant such as Bondo 606 or a low viscosity epoxy such as Global PX768 should be poured into any cracks, and then squeegeed smooth. Any loose asphaltic material should be wire brushed away prior to pouring the sealant material in the cracks. Be careful not to raise the profile of the sensor. The sensor should be tested for capacitance and resistance, and the results logged in on the data sheet for the sensors.

Additional Roadtrax® Installation Diagrams

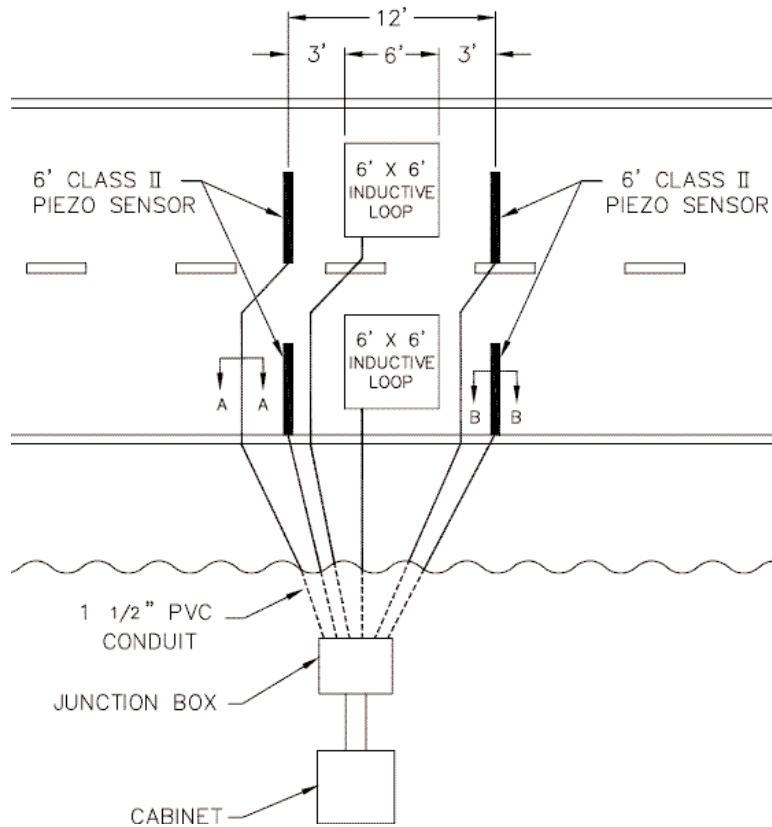

NOTE: Layout diagrams are examples only. Always follow the issuing authority's official project specifications for exact layout diagrams.

Typical installation layout for a Piezo-Loop-Piezo installation for 6' Class II sensors

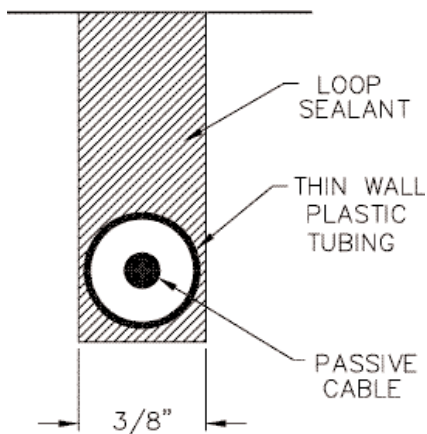

A-A: The passive cable can be put in a thin wall plastic tube for additional protection.

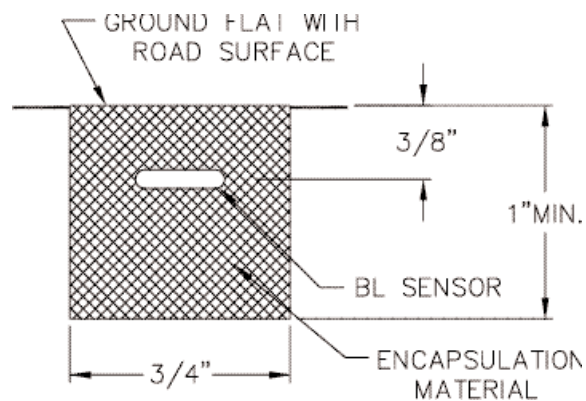

B-B: Typical cross section of a BL Sensor installation.

Frequently Asked Questions: Approved Grout for installation:

Polyurethane

PU 200 or PU 260 (Winter and Summer versions are available)

Global Resins Limited
Unit 7
Park Lane Industrial Estate
Corsham, Wilts SN13 9LG
England
Tel: +44 1249 715566
Fax: +44 1249 715533

Available in the USA through:
ITC/PAT America Inc.
2402 Spring Ridge Dr, Suite E
Spring Grove, IL 60081
Tel: 815 675 1430
Fax: 815 675 1530

Epoxy

None

Acrylic

AS475
International Road Dynamics
702 43rd Street East
Saskatoon, Saskatchewan
Canada S7K 3T9
Tel: 306 653 6600
Fax: 306 242 5599
Available in the USA through
Measurement Specialties.

ECM P6G
Electronic Control Measurement
Inc
PO Box 888
Manor, TX 78653
Tel: 512 272 4346
Fax: 512 272 4966

Other Material Suppliers:

Diamond Saw Blades

Texas Diamond Tools
805 Hilbig Rd
Conroe, TX 77301
Tel: 800 346 0646
Tel: 935 756 0646
Fax: 935 756 0687
14x.750x.250x1 ,
PN# 07147507
www.texasdiamondtools.com

Bituthane Pocket Tape for Temporary installations

Mar Mac Manufacturing Co, Inc
PO Box 447
McBee, SC 29101
Tel: 843 335 8211
Fax: 843 335 5814
Tape ST0005604 (4 wide with a 2 pocket)
www.marmac.com

BNC Connectors

Tyco Electronics
www.amp.com
Tel: 1-800 52AMP52
Also available through Newark
Electric and other Distributors
Part Number 5227079-5

NOTES:

The Measurement Specialties Roadtrax® Brass Linguini® axle sensor

■ Great Signal

- ★ Positive signal as tires pass over the sensor
- ★ Good dynamic range - works with large to small vehicles
- ★ Reduced Road Flexing noise
- ★ High Signal to Noise Ratio for ease of signal processing
- ★ High capacitance - can drive long cables
- ★ Works even for slow speeds

■ Easy to Handle

- ★ Conforms to any road profile
- ★ Coils in a 2'x2' (600x600mm) box
- ★ Rugged so that it does not break in handling

■ Easy Installation

- ★ Installs in a 3/4 x 1 (19 x 25mm) cut in the road to minimize damage to the road
- ★ Installs with fast curing epoxy, acrylic, or appropriate poly-urethane
- ★ Smaller cut means less encapsulation material

■ Quality

- ★ All sensors are 100% tested for capacitance, insulation resistance, piezo activity and uniformity
- ★ Computerized process controls the extrusion and polarization of the cable
- ★ All sensors Serial Numbered for traceability

■ Durability

- ★ Triple sealed coax splice between the sensor and the passive cable
- ★ The sensor will not be damaged by bending to a radius of > 1' (300mm)
- ★ Will withstand normal handling
- ★ Tested to 40 Million Equivalent Single Axle Loadings

■ Versatility

- ★ Same sensor for over and in the road applications
- ★ Surface sensors can be mounted permanently or temporarily
- ★ Can be used in Portland Cement or Asphalt
- ★ Available in many lengths - both English and Metric - with cable lengths from 100' to 300' (35m to 100m). Longer lengths available on custom basis

■ Great Passive Cable

- ★ Super tough High Density Poly Ethylene (HDPE)
- ★ Rated as Waterproof for direct burial

■ Customer Support

- ★ Fast delivery - Units in stock
- ★ Installation clips included with all sensors
- ★ Installation instructions included with all sensors
- ★ Available Internationally
- ★ On site installation training available