

p-T-Sensor

Type 6190CA...

for Mold Cavity Pressure and Temperature with Front $\varnothing 4$ mm

Sensor for the combined measurement of mold cavity pressure up to 2 000 bar and contact temperature in the cavity during the injection molding of plastics. Design without diaphragm and with flat front.

- Pressure sensor with integral thermocouple for pressure and temperature measurement
- Mounting dimensions compatible with Kistler pressure sensors Types 6157B... and 6177A...
- Replaceable connecting cable

Description

The sensor for mold cavity pressure and temperature measurement has a front face of 4 mm diameter.

The pressure acts directly on the entire front face of the sensor and is transferred to the crystal force link, which produces an electric charge ($pC = \text{picocoulomb}$) proportional to the pressure. This is converted by an amplifier into a voltage of 0 ... 10 V which is available at the amplifier output.

The contact temperature of the melt is measured on the front side of the sensor by a thermocouple pair Type K (NiCr-Ni). The front face of the sensor cannot be machined. The small sensor dimensions result in a quick temperature-sensor response time. The rugged combi-cable feeds both the pressure signal and the temperature signal to two connectors. The cable is screwed behind the sensor with a union nut and can be exchanged.

Sensors without connectors Type 6190CAG are available for multi-cavity molds. The charge cable can then be connected to the multi-channel connector Type 1708A... or 1710A... and the two temperature conductors to the temperature amplifier Type 2205A...

Application

The sensor measures the mold cavity pressure and the contact temperature of the molding in the cavity. It is suitable in industrial applications for optimising monitoring and controlling the injection molding of thermoplastics and elastomers. The additional temperature data provides valuable process information.

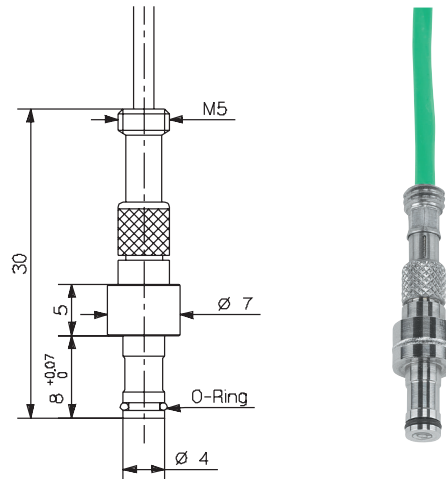

This is particularly useful in the analysis of the surface of the molding, as well as in the evaluation of knit lines in components with long flow paths.

Technical Data

Range	bar	0 .. 2 000
Overload	bar	2 500
Sensitivity	pC/bar	-9
Linearity, all ranges	%FSO	$\leq \pm 1$
Thermocouple Type K		NiCr-Ni
Leads		
positive	+	green
negative	-	white
Operating temperature range		
Mold (sensor, cable, connector housing)	$^{\circ}C$	*0 ... 200
Melt (at the front of the sensor)	$^{\circ}C$	<450
Insulation resistance		
at 20 $^{\circ}C$	Ω	$>10^{13}$
at 200 $^{\circ}C$	Ω	$>10^{12}$

* During machine down-time, the mold temperature may be allowed to rise to 240 $^{\circ}C$ without damaging the sensor. However, measuring errors may occur.

6190CA_000-680e-04.11

QUALITY MOLDING
powered by Kistler

This information corresponds to the current state of knowledge. Kistler reserves the right to make technical changes. Liability for consequential damage resulting from the use of Kistler products is excluded.

©2008 ... 2011, Kistler Group, Eulachstrasse 22, 8408 Winterthur, Switzerland
Tel. +41 52 224 11 11, Fax +41 52 224 14 14, info@kistler.com, www.kistler.com
Kistler is a registered trademark of Kistler Holding AG.

Cable and Amplifier for Measuring Chains with Sensor Type 6190CA...

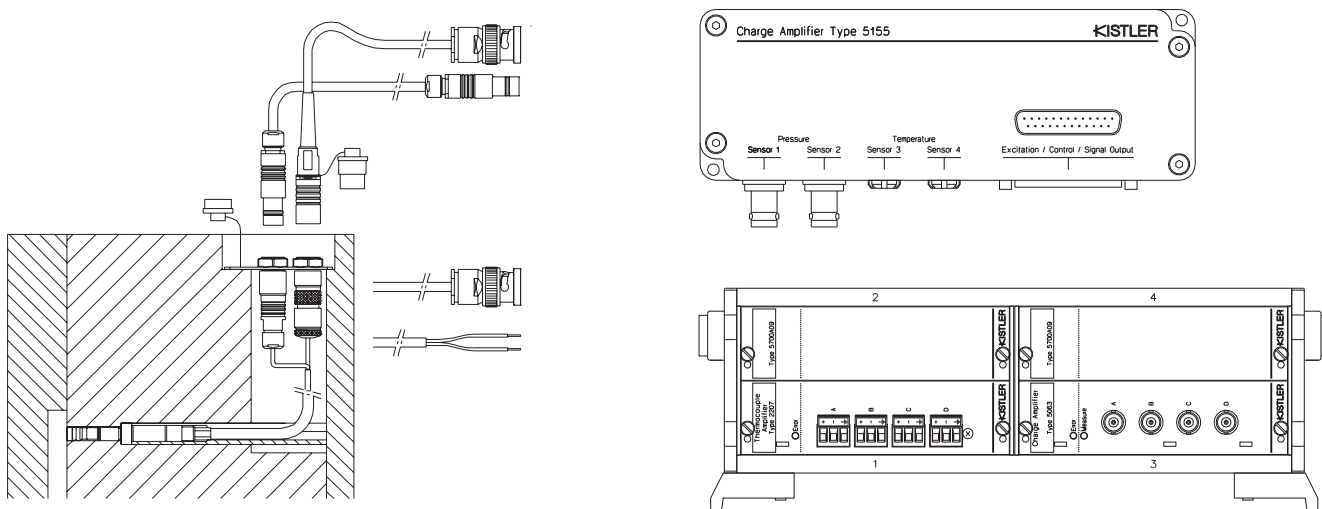

Cable Type 1667B... (BNC connector) for charge	Cable Type 1672B... (TNC connector) for charge	Compensating line Type 2295A... for temperature	Compensating line Type 2290A... (open ends) for temperature
Type 5155AxxBx/AxxDx	Type 5155AxxAx	Type 5155AxxAx/AxxBx	Type 2207A in Type 2859A...
Type 5063A1 in Type 2859.../2865...	Type 5155AxxCx	Type 5155AxxCx/AxxDx	Type 2207A in Type 2865A...

Fig. 1: Sensor Type 6190CA... with charge and temperature amplifier Type 5155A... or signal conditioner Type 2859A.../2865A...

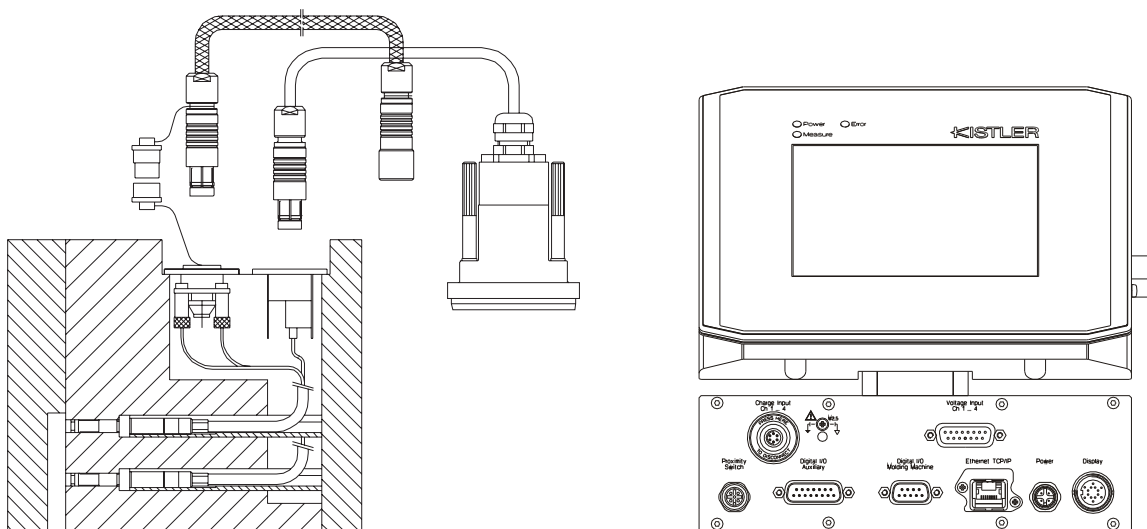

4-channel cable Type 1995A... to connector Type 1708A... for charge	4-channel cable Type 1457A1A... to temperature amplifier Type 2205A... for temperature
Type 2869A0xx	Type 2869A1xx
Type 2869A1xx	

Fig. 2: Sensor Type 6190CA... with monitoring system CoMo Injection Type 2869A...

6190CA_000-680e-04.11

Mounting Examples

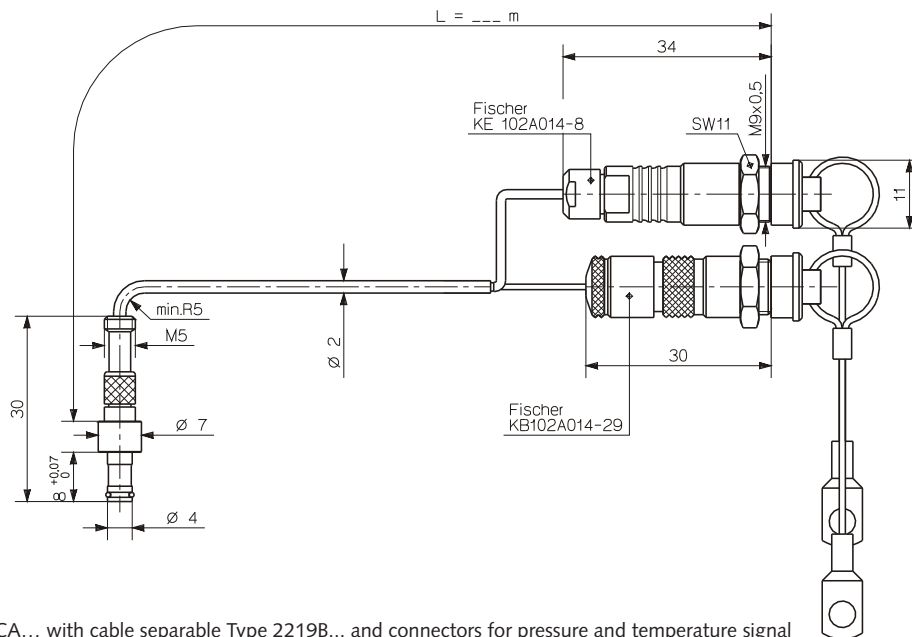

Fig. 3: Sensor Type 6190CA... with cable separable Type 2219B... and connectors for pressure and temperature signal

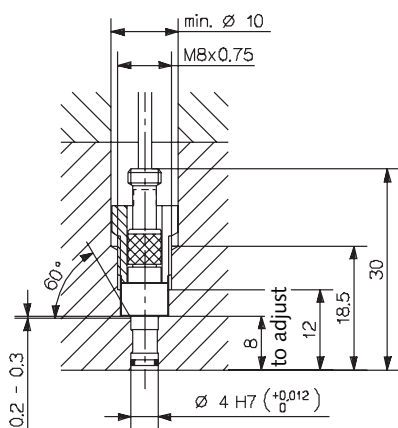

Fig. 4: Mounting with mounting nut Type 6457

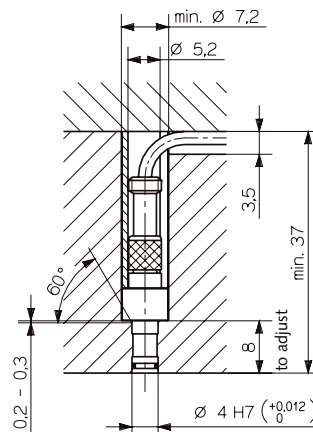

Fig. 5: Mounting with spacer sleeve Type 6459

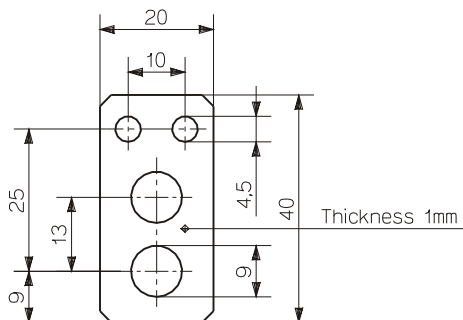

Fig. 6: Mounting plate Art. No. 3.520.1015

Mounting

The sensor is normally installed in the mounting hole with a mounting nut Type 6457. A spacer sleeve Type 6459 can also be used. Since the sensor forms part of the cavity wall, it must be mounted in such a way that its front face is exactly flush. The sensor is therefore center aligned in the hole with 4mm/H7 diameter.

The cable must be mounted completely in the mold. The two connectors are attached in the mounting plate which is inserted in the mold. The multiconductor cable uses the single-wire technique, that is the pressure signal is fed via a single cable and the mold acts as a shield.

Accessories Included

	Type/Art. No.
• Mounting nut	6457
• Mounting plate (only for sensor with cable)	3.520.1015
• Connector (charge)	5.511.364
• Connector (temperature)	5.511.246
• Cap	7.621.115
• Identification plate	3.520.1016
• O-ring	1100A57

Optional Accessories

	Type
Sensor connecting cable with connectors as spare cable	
• Length l = 0,4 m	2219B0,4
• Length l = 0,8 m	2219B0,8
• Length l = 1,2 m	2219B1,2
• Length l = 1,6 m	2219B1,6
• Length l = 2 m	2219B2
• Length l = 5 m for special cable length	2219Bsp

Sensor connecting cable without connector as spare cable	
• Length l = 2 m	2219BG
• Length l = 5 m for special cable length	2219BG1

High temperature extension cable (pressure) Fischer SE102 A014 – BNC pos.	
• Length l = 2 m	1667B2
• Length l = 5 m	1667B5

High temperature extension cable (pressure) Fischer SE102 A014 – TNC pos.	
• Length l = 2 m	1672B2
• Length l = 5 m	1672B5

Temperature compensation cable for connection to Type 5155A...	
• Length l = 2 m	2295A2
• Length l = 5 m	2295A5

Optional Accessories

	Type
Temperature compensation cable	
One way open ended	
• Length l = 2 m	2290A2
• Length l = 5 m	2290A5
• Extraction tool	1315A
• Socket wrench for mounting nut	1383
• Dummy sensor	6545
• Spacer sleeve (length l = 50 mm)	6459

Optional connectors and temperature amplifiers

To be used only with Type 6190CAG/G1	
• 4-channel connector (charge)	1708A...
• 8-channel connector (charge)	1710A...
• 2-channel temperature amplifier	2205A...2...
• 4-channel temperature amplifier	2205A...4...
• Adapterplatte für 2 Stecker	5700A25
• Cable stripping tool	1367

Checking Tools

	Art. No.
• Limit plug gage, diameter 4 H7	5.210.162
• Checking tool	7.110.300

Ordering Key

Type 6190CA <input type="checkbox"/>	
Cable Length	
Length l = 0,4 m	0,4
Length l = 0,8 m	0,8
Length l = 1,2 m	1,2
Length l = 1,6 m	1,6
Length l = 2 m	2
Combi-cable with special length, specify cable length L in m (L _{min} = 0,15 m/L _{max} = 5 m)	sp
Sensor without connector, Cable length l = 2 m	G
Sensor without connector, Cable length l = 5 m	G1