

Cylinder Pressure Sensor

for Continuous Monitoring

Type 6613CA

Sensor designed with optimum service life for continuous cylinder pressure monitoring in diesel and gas engines. Because of its low thermal shock and high stability over the long term, this sensor is suitable for demanding monitoring and control tasks.

- Small thermal shock
- Long life: >20 000 h
- Insensitive to integral mounting

Description

The quartz measuring element and the charge amplifier incorporated in the plug are interconnected by an integral cable. The charge amplifier has two measuring ranges and selectable time constants. The short time constant guarantees stability of the output signal even with rapid changes in load and speed. The long time constant allows static calibration of the measuring chain. The measuring range and/or time constants are selected by appropriate interconnection of the plug pins. As a result of its patented "antistrain" design, the measuring element is insensitive to integral mounting, and largely insensitive to dirt and contamination. The rugged diaphragm permits the sensor to be used for knock detection.

The life expectancy of the sensor has been designed so that a life of >20 000 h can be achieved in a diesel and gas engine running. With heavy-oil operation, the service life depends very much on the corrosion occurring, while extreme contamination can reduce measuring accuracy.

Application

Type 6613CA has been specially developed for the monitoring and control of medium and large size diesel and gas engines. Cylinder pressure measurements can be made with high precision because of its very good thermodynamic characteristics.

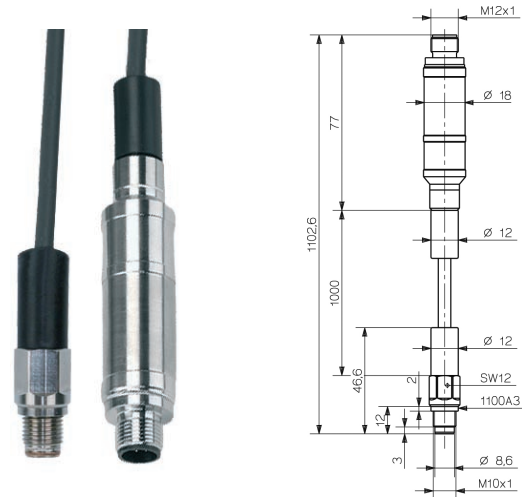

Technical Data

Measuring range		
Range I	bar	0 ... 250
Range II	bar	0 ... 100
Sensitivity		
Range I ($\pm 0,5\%$)	mV/bar	10
Range II ($\pm 0,5\%$)	mV/bar	25
Overload	bar	300
Linearity	% FSO	$\leq \pm 1$
Sensitivity to acceleration	bar/g	0,001
Operating temperature range		
Sensor	$^{\circ}\text{C}$	-50 ... 350
Plug with charge amplifier	$^{\circ}\text{C}$	-10 ... 85
Thermal shock at 1 500 1/min, $p_{mi} = 9$ bar	bar	$\leq \pm 0,5$
Change in sensitivity		
200 \pm 150 $^{\circ}\text{C}$	%	$\leq \pm 2$
200 \pm 50 $^{\circ}\text{C}$	%	$\leq \pm 1$
Frequency range (-3 dB)	Hz	0,032 ... 20 000
Output voltage (with 1 mA load)		
max.	V	4,4 ... 5
min.	V	>0
Signal range	V	2,5
Zero point	V	2 ... 2,2
Supply voltage	VDC	7 ... 32
Output impedance	Ω	100
Plug DIN	M12x1	IP67
Weight	g	140
Tightening torque	N·m	15
Connector	8 pin	M12x1

Page 1/2

This information corresponds to the current state of knowledge. Kistler reserves the right to make technical changes. Liability for consequential damage resulting from the use of Kistler products is excluded.

©2009, Kistler Group, Eulachstrasse 22, 8408 Winterthur, Switzerland
Tel. +41 52 224 11 11, Fax +41 52 224 14 14, info@kistler.com, www.kistler.com

Installation

In order to minimize thermal stress on the sensor, it should be located so that good heat dissipation to colder components is possible. This can normally be achieved by a set-back location. Optimum sensor life is achieved at an average temperature of 200 ... 300 °C in the sensor body. An angled gas channel can also reduce the effect of flame on the diaphragm, and thereby minimize the short term drift of the sensor. In order to prevent singing oscillations, the lengths of the gas channel should not exceed 30 mm. Strong gas oscillations occur when the gas column between sensor and combustion chamber resonates. Superimposed on the cylinder pressure, these pressure oscillations impose an additional load on the sensor, resulting in reduced life of the sensor.

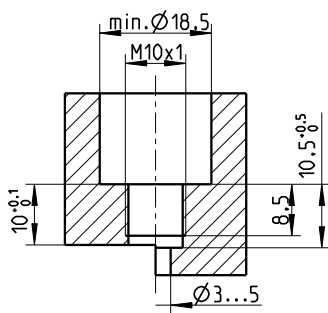

Fig. 1: Sensor bore



Fig. 2: Type 6613CA installed in indicator with additional stop valve for the sensor

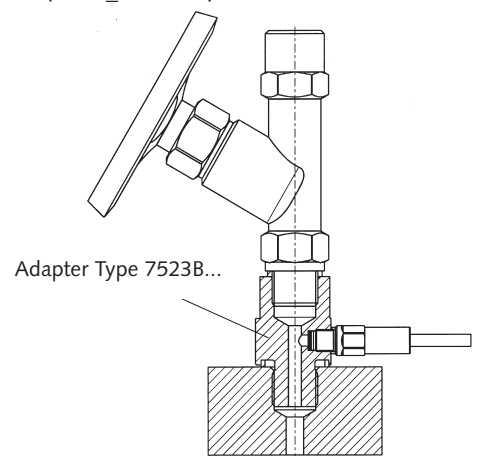

Fig. 3: Sensor installed with adapter Type 7523B... underneath the indicator valve

Accessories Included

- Cr-Ni seal

Type
1100A3

Optional Accessories

- Torque wrench 8 ... 40 N·m*
- Fork wrench SW 12 for 1300A11*
- Adapter M14 x 1,25
- Adapter BSP R1/2"
- Adapter M20x1,5 ... M20x1,5
- Adapter BSW3/4 ... BSW3/4
- Adapter G1/2" x G1/2"
- Tubular socket wrench

Type
1300A11
1300A13
6582A1
6582A2
7523B01
7523B02
7523B03
1300A6

* refer to data sheet special tools and sensor dummies (1300_000-068)

Connecting Cables

Type 1700A69, plug M12x1 at sensor side, one free cable end, Cable length l = 10 m, 3-wires	black = GND	standard cable without range selection,
	blue = signal 2,5 Vpp = 250 bar	
	brown = power supply 7 ... 32 VDC	
Type 1700A71, plug M12x1 at sensor side, one free cable end, Cable length l = 10 m, 4-wires	black = GND	standard cable, enables range selection, Range I/Range II
	blue = signal 2,5 Vpp = 250 bar	
	brown = power supply 7 ... 32 VDC	
	white = range selection (see manual)	
Type 1787A..., plug M12x1 at sensor side, Cable length A5 = 5 m, A20 = 20 m 8-wires	Pin allocation, see manual of Type 6613CA Chapt. 3.2.5	For calibration only, enables selection of range and time constant

Ordering Code

Cylinder pressure sensor for continuous monitoring 6613CA

Type

6613CA