

# Mold Cavity Pressure Sensor

## Unisens® with Front $\varnothing 6$ mm

Type 6152A...

Patent No. US 6,212,963

Quartz sensor for cavity pressures up to 2 000 bar for injection molding of plastics.

- ideally suited for industrial applications
- sensor front can be machined to adapt to the cavity wall (except for coated versions of the sensor)
- exchangeable cable

### Description

The sensor Type 6152AE consists of the Unisens quartz sensor for mold cavity pressure Type 6157BE with exchangeable cable, fitted in a rugged adapter. The sensor Type 6157BE with 4 mm front diameter comes flush with the adapter front with an annular gap of  $<10 \mu\text{m}$  and measures the pressure directly.

The pressure acts over the entire front of the sensor and is transmitted to the quartz measuring element, which produces a proportional electric charge ( $\text{pC} = \text{Picocoloumb}$ ). This is converted into a voltage  $0 \dots 10 \text{ V}$  in the amplifier and is then available as an amplifier output.

All parts of the sensor are corrosion-resistant. The exchangeable cable is screwed to the sensor with a tight seal. The connector is self-locking and splash-proof.

For multi cavity applications the sensor Types 6152AA... and 6152AC... are used without the single-wire connector Typ 1839. The Multi Cavity Set Type 6829A... and the Multi Sensor System Type 6831A... are described in the appropriate data sheets.

This sensor is available with several types of connecting cables (see page 2).

### Application

This diaphragm-free sensor measures mold cavity pressures up to 2 000 bar during injection molding. It is particularly suitable for optimizing, monitoring and controlling the injection molding process of thermoplastics, elastomers, thermosets and SMC.

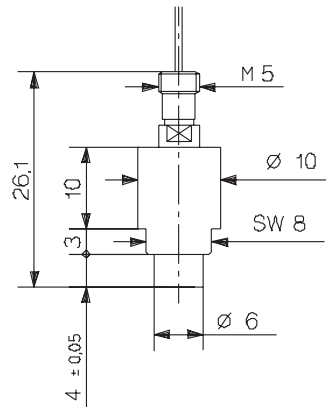

For abrasive melts (e.g. filled with glass fibers or carbon fibers, thermosets, BMC/SMC), these sensors are available as Types 6152ACE/ADE with a coated front.

With low viscosity melts (e.g. thermosets, SMC/BMC, IC sheaths), the silicone-filled Types 6152AAAE/ACAE must be used.

### Technical Data

Range	bar	0 ... 2 000
Overload	bar	2 500
Uniform sensitivity	pC/bar	-9,4
Linearity, all ranges	% FSO	$\leq \pm 1$
Operating temperature range		
Mold (Sensor, Cable)		
6152AA.../A...E/AA.../AC...	°C	200
6152AB.../AD...	°C	300
Melt (at front of sensor)	°C	$< 450$
Connector	°C	0 ... 200*
Insulation resistance		
at 20 °C	T $\Omega$	$> 100$
at 300 °C	T $\Omega$	$> 0,01$

\* During machine down time, the mold temperature may rise to 240 °C without damaging the sensor; however, this may lead to measuring errors.

6152A\_000-028e-02.07

**Pressure Sensor Type 6152AA.../AC**

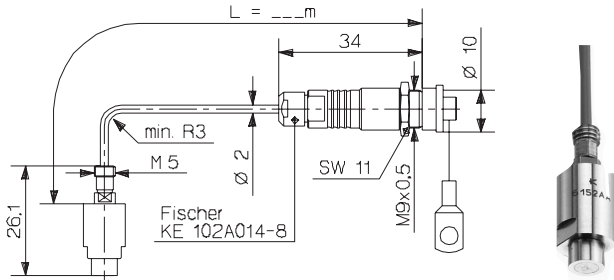

Sensor with coaxial cable for temperature up to 200 °C.

can be cut to length as required. With the single-wire technique, electrical shielding is provided by the mold. It is therefore essential for the cable and connector to be completely integrated in the mold. To ensure easy installation, a connector is included which is self-locking and splash-proof.

The following sensors with single-wire technique are available:

Types 6152AAE, 6152AAAE, 6152ACE and 6152ACAE

**Special versions**

Coated front (abrasion protection)

- Type 6152AAE with coated front: Type 6152ACE
- Type 6152ABE with coated front: Type 6152ADE

**Pressure Sensor Type 6152AB.../AD**

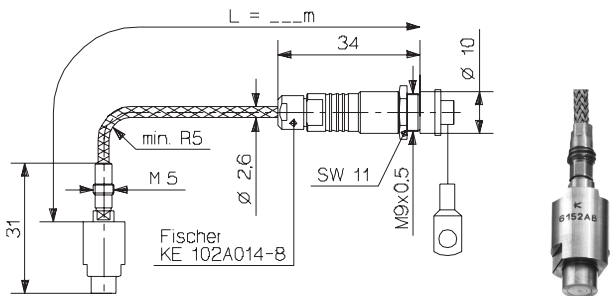

Special version of the sensor Type 6152AE with extended operating temperature range up to 300 °C. This sensor is suitable for special materials. Exchangeable steel-braided polyamide cable (Kapton) with connector.

Silicone-filled gap

(not possible with Types 6152ABE and 6152ADE)

- Type 6152AAE gap filled with silicone: Type 6152AAAE
- Type 6152ACE gap filled with silicone: Type 6152ACAE

**Montage**

The sensor is normally fixed in the mounting bore with the mounting nut (Type 6453), but a spacer sleeve (Type 6459) can also be used.

The sensor front forms part of the cavity wall. The sensor must therefore be adapted so that its front comes exactly flush and leaves no impression on the molded part. The front can be further machined up to 0,5 mm (except with a coated front!). Full details may be found in the operating instructions.

The sensor is center aligned in the 6 H7 bore.

**Pressure Sensor Type 6152A...E**

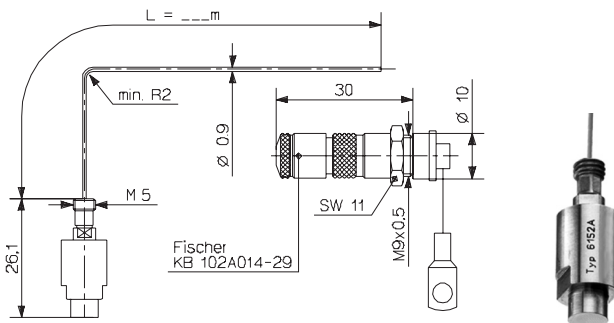

Sensor using single-wire technique for easy installation. The sensor Type 6152AEE is provided with a single-wire cable with a very small cross-sectional area and can be installed flexibly in the injection mold. The single-wire cable is exchangeable and

6152A\_000-028e-02.07

**Cable and Amplifier for Measuring Chain with Sensor Type 6152A...**

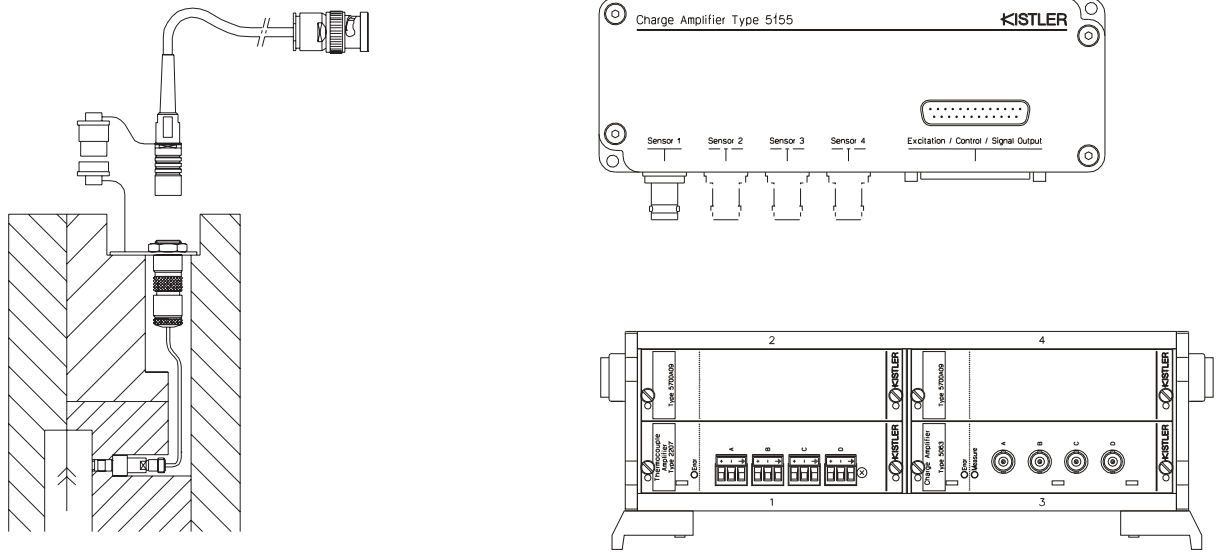

Cable Type 1667B... (BNC Connector)	Cable Type 1672B... (TNC Connector)
Type 5039Axx2	Type 5039Axx1
Type 5049Axx2	Type 5049Axx1
Type 5155Axx2x/Axx4x/Axx8x	Type 5155Axx1x/Axx3x/Axx7x
Type 5063A1 in Type 2859A.../2865A...	

Fig. 1: Sensor Type 6152A... with Charge Amplifier Typ 5155A... or Signal Conditioner Type 2859/2865A...

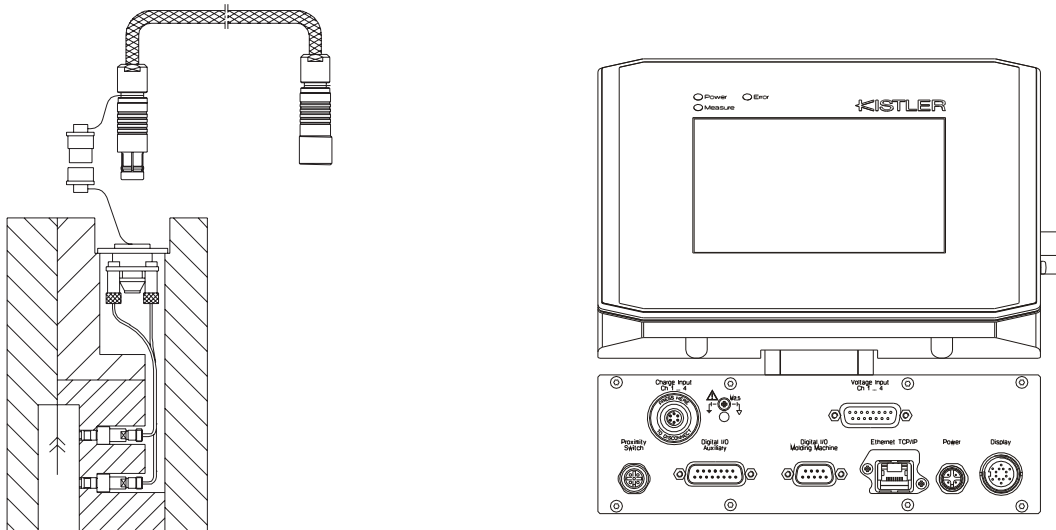

4-Channel Cable Type 1995A... to Connector Type 1708A..	8-Channel Cable Type 1997A... on Connector Type 1710A...
Type 2869A0xx	Type 2869A2xx
Type 2869A1xx	

Fig. 2: Sensor Type 6152A... with Monitoring System CoMo® Injection Typ 2869A...

6152A\_000-028e-02.07

This information corresponds to the current state of knowledge. Kistler reserves the right to make technical changes. Liability for consequential damage resulting from the use of Kistler products is excluded.

©2007, Kistler Instrumente AG, PO Box, Eulachstr. 22, CH-8408 Winterthur  
Tel +41 52 224 11 11, Fax +41 52 224 14 14, info@kistler.com, www.kistler.com

Installation Examples

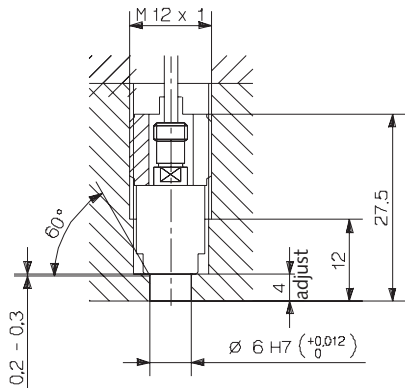

Fig. 3: Installation with mounting nut Type 6453

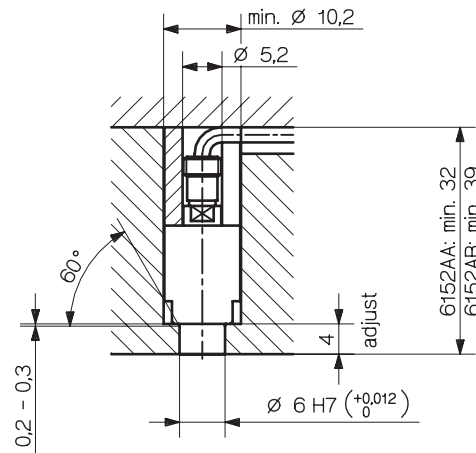

Fig. 4: Installation with spacer sleeve Type 6462

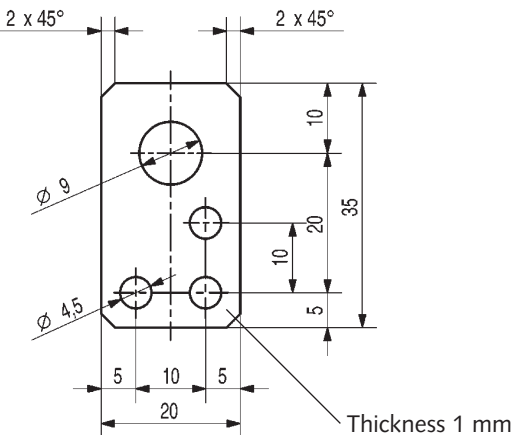

Fig. 5: Mounting plate (Art. No. 3.520.328)

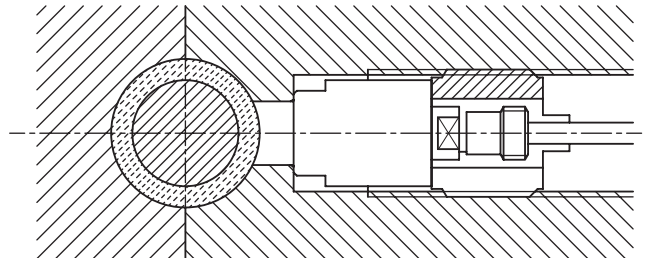

Fig. 6: Sensor with machined front (Types 6152AA... and 6152AB... only)

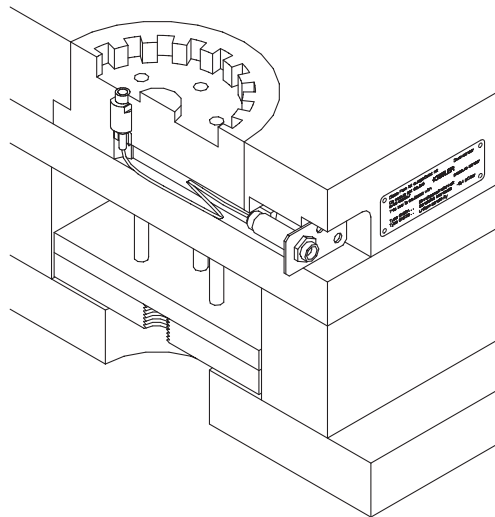

Fig. 7: Sensor, cable, mounting plate (Art. No. 3.520.328) and identification label (Art. No. 3.520.899)

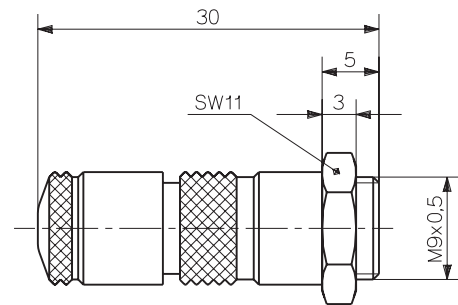

Fig. 8: Connector (Type 1839)

6152A\_000-028e-02.07

**Accessories Included**

	Art. No./Type
• Mounting nut	6453
• Mounting plate (for sensor with cable only)	3.520.328
• identification label	3.520.899
• Connector (for single-wire technique only)	1839
• Single-wire cable, with the length of 1,5 m (ready installed with sensor, for single-wire technique only)	1666A1
• Single-wire cable, with the length of 5 m (ready installed with sensor, for single-wire technique only)	1666A3

**Optional Accessories**

	Art. No./Type
• High temperature extension cable Viton® Fischer SE102A014 – BNC pos., Length 2 m	1667B2
Length 5 m	1667B5

- High temperature extension cable Viton Fischer SE102A014 – TNC pos.,  
Length 2 m 1672B2  
Length 5 m 1672B5
- Spacer sleeve 6462
- 4 channel connector for  
Type 6152A...G and G1 1708A...
- 8 channel connector for  
Type 6152A...G and G1 1710A...
- Dummy sensor 6552
- O-ring, ø2,5x0,65 mm,  
(for Type 6152AAE only) 1100A57
- O-ring, ø2,5x0,65 mm,  
(for Type 6152ABE only) 1100A67

**Mounting Accessories**

	Type
• Socket wrench	1383
• Extraction tool	1315A
• Key for mounting nut	1352
• Tap M 12x1	1355
• Mounting piece for connector	1401

**Ordering Key**

**Sensor**

up to 200 °C	<b>A</b>
up to 300 °C	<b>B</b>
up to 200 °C, sensor front coated	<b>C</b>
up to 300 °C, sensor front coated	<b>D</b>

Gap between sensor adapter filled with Silicone (only for Types 6152AA... and 6152AC...)	<b>A</b>
---	----------

**Cable**

Coaxial cable, L in m (Type 6152AB... and Type 6152AD... only available as 0,4 and sp)	<b>0,2</b>
	<b>0,4</b>
	<b>0,6</b>
	<b>0,8</b>
Coaxial cable with special lengths, specify L in m (L <sub>min</sub> = 0,1 m / L <sub>max</sub> = 5 m)	<b>sp</b>
with single-wire-cable available only for Type 6152AA... and Type 6152AC... (L = 1,5 m)	<b>E</b>
with single-wire-cable available only for Type 6152AA... and Type 6152AC... (L = 5 m)	<b>E1</b>
Type 6152AAE or 6152ACE (L = 1,5 m) without connector	<b>G</b>
Type 6152AAE1 or 6152ACE1 (L = 5 m) without connector	<b>G1</b>

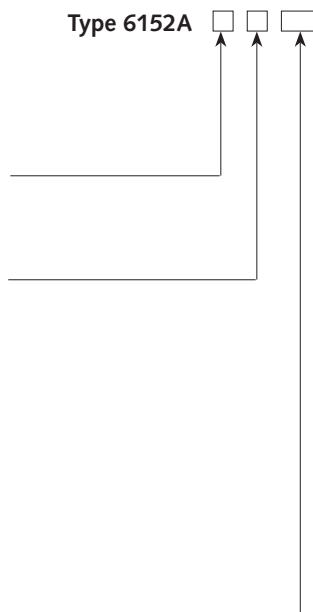

Viton® is a registered Trademark of DuPont Performance Elastomers.