

PACKAGE DIMENSIONS inch (mm)

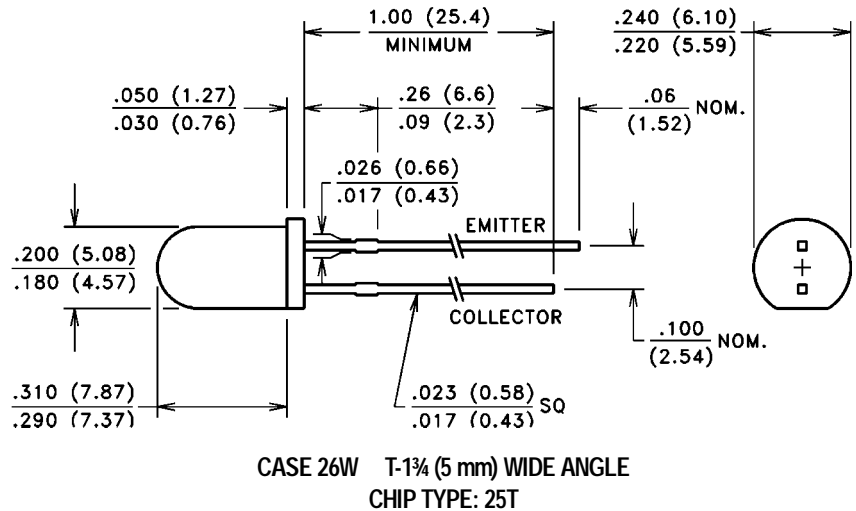

PRODUCT DESCRIPTION

A small area high speed NPN silicon phototransistor mounted in a 5 mm diameter lensed, end looking, transparent plastic package. Detectors in this series have a half power acceptance angle ($\theta_{1/2}$) of 40°. These devices are spectrally and mechanically matched to the VTE12xxWH series of IREDS.

ABSOLUTE MAXIMUM RATINGS ■

(@ 25°C unless otherwise noted)

Maximum Temperatures	
Storage Temperature:	-40°C to 100°C
Operating Temperature:	-40°C to 100°C
Continuous Power Dissipation:	50 mW
Derate above 30°C:	0.71 mW/°C
Maximum Current:	25 mA
Lead Soldering Temperature:	260°C
	(1.6 mm from case, 5 sec. max.)

RoHS Compliant



ELECTRO-OPTICAL CHARACTERISTICS @ 25°C (See also typical curves, pages 91-92)

Part Number	Light Current		Dark Current		Collector Breakdown	Emitter Breakdown	Saturation Voltage	Rise/Fall Time	Angular Response $\theta_{1/2}$	
	I_C		I_{CEO}		$V_{BR(CEO)}$	$V_{BR(ECO)}$	$V_{CE(SAT)}$	t_R/t_F		
	mA	H fc (mW/cm ²) $V_{CE} = 5.0 V$	H = 0	$I_C = 100 \mu A$ H = 0	$I_E = 100 \mu A$ H = 0	$I_C = 1.0 mA$ H = 400 fc	$I_C = 1.0 mA$ $R_L = 100 \Omega$			
	Min.	Max.	(nA) Max.	V_{CE} (Volts)	Volts, Min.	Volts, Min.	Volts, Max.	μsec , Typ.		
VTT1222WH	0.9	—	100 (5)	10	20	50	6.0	0.25	2.0	$\pm 40^\circ$
VTT1223WH	1.5	—	100 (5)	10	20	40	6.0	0.25	3.0	$\pm 40^\circ$

■ Refer to General Product Notes, page 2.