

**SMALL PACKAGE PWM CONTROL
STEP-UP SWITCHING REGULATOR**

S-8323/8327 Series

The S-8323/8327 Series is a CMOS PWM-control step-up switching regulator which mainly consists of a reference voltage source, an oscillation circuit, a power MOS FET (for S-8323 Series) , and an error amplifier. Equipped with best-designed control circuits, the products maintain high efficiency over a wide range of conditions with the capability of automatically controlling the duty ratio from 0% to 83% (78% for 250kHz model) according to each applied load. A step-up switching regulator is constructed by externally connecting only a coil, a capacitor and a diode to the S-8323 Series. This feature, along with its small package and low current consumption, makes the S-8323 Series ideal for the power supply of portable equipment. For applications requiring a high output current, products used with an external transistor (S-8327 Series) are also available.

■ **Features**

- Low voltage operation:
0.9V(I_{OUT}=1mA, 50kHz and 100kHz models)
- Low current consumption :
During operation: 17.2μA (typ.)
(V_{OUT} = 3 V, 50 kHz)
During shutdown: 0.5μA (max.)
- Duty ratio: Built-in PWM control circuit
- External parts: coil, diode, and capacitor only
(a transistor is needed for the S-8327 Series.)
- Output voltage: accuracy of ±2.4%
- Oscillation frequency: 30kHz, 50kHz, 100kHz, and 250kHz
- Software start function is built-in
- Shutdown function
- External transistor type is available (S-8327 Series)
- SOT-23-5 small plastic package
- SOT-23-3 small plastic package
- SOT-89-3 miniature power molded plastic package
- Step-down and voltage-inverting type are available.

■ **Applications**

- Power supplies for portable equipment such as pagers, handy calculators, and remote controllers
- Constant voltage power supplies for cameras, video equipment, and communications equipment
- Power supply for microcomputers

■ **Block Diagram**

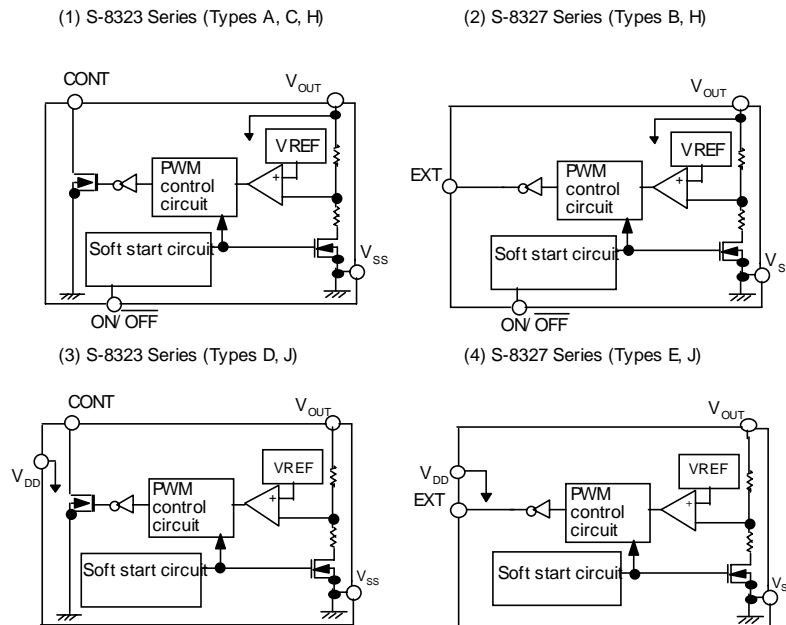
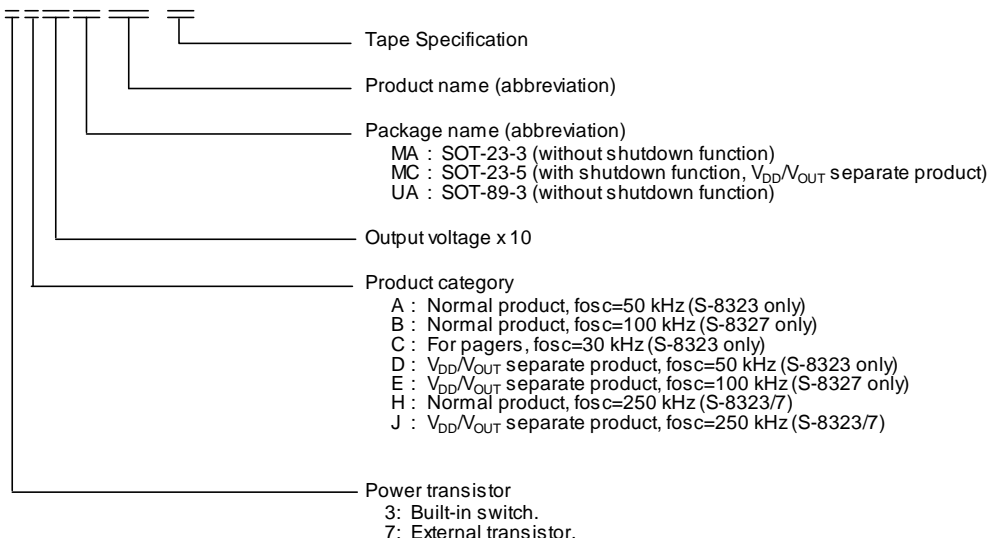

Figure 1 Block Diagram

■ **Selection Guide**

1. Product Name

S-832 X X XX XX - XXX - T2



2. Function List

Product Name	Built In power transistor	with external power transistor	Switching frequency (kHz)	shutdown function	V_{DD}/V_{OUT} separate type	Package	Application
S-8323AXXMC	Yes	—	50	Yes	—	SOT-23-5	With shutdown function
S-8323AXXMA	Yes	—	50	—	—	SOT-23-3	Without shutdown function
S-8323AXXUA	Yes	—	50	—	—	SOT-89-3	Without shutdown function
S-8323DXXMC	Yes	—	50	—	Yes	SOT-23-5	For variable output voltage by step-up DC/DC converter and step-down, inverted output DC/DC converter with an external resistor
S-8323CXXMA	Yes	—	30	—	—	SOT-23-3	For pagers
S-8323HXXMC	Yes	—	250	Yes	—	SOT-23-5	With shutdown function
S-8323JXXMC	Yes	—	250	—	Yes	SOT-23-5	For variable output voltage by step-up DC/DC converter and step-down, inverted output DC/DC converter with an external resistor
S-8327BXXMC	—	Yes	100	Yes	—	SOT-23-5	For large load current with shutdown function
S-8327BXXMA	—	Yes	100	—	—	SOT-23-3	For large load current without shutdown function
S-8327BXXUA	—	Yes	100	—	—	SOT-89-3	For large load current without shutdown function
S-8327EXXMC	—	Yes	100	—	Yes	SOT-23-5	For variable output voltage by step-up DC/DC converter with an external resistor
S-8327HXXMC	—	Yes	250	Yes	—	SOT-23-5	For large load current without shutdown function
S-8327JXXMC	—	Yes	250	—	Yes	SOT-23-5	For variable output voltage by step-up DC/DC converter with an external resistor

SMALL PACKAGE PWM CONTROL STEP-UP SWITCHING REGULATOR

Rev. 7.2

S-8323/8327 Series

3. Product list

Output voltage (V)	S-8323AXXMC Series	S-8323AXXMA Series	S-8323AXXUA Series	S-8323CXXMA Series	S-8323DXXMC Series
2.0	S-8323A20MC-ELA-T2	—	—	—	S-8323D20MC-EZA-T2
2.5	S-8323A25MC-ELF-T2	S-8323A25MA-ELF-T2	S-8323A25UA-ELF-T2	S-8323C25MA-ENF-T2	—
2.7	S-8323A27MC-ELH-T2	S-8323A27MA-ELH-T2	S-8323A27UA-ELH-T2	S-8323C27MA-ENH-T2	—
2.8	S-8323A28MC-ELI-T2	—	—	—	—
3.0	S-8323A30MC-ELK-T2	S-8323A30MA-ELK-T2	S-8323A30UA-ELK-T2	S-8323C30MA-ENK-T2	S-8323D30MC-EZK-T2
3.3	S-8323A33MC-ELN-T2	S-8323A33MA-ELN-T2	S-8323A33UA-ELN-T2	—	—
3.8	S-8323A38MC-ELS-T2	—	—	—	—
4.4	S-8323A44MC-ELY-T2	—	—	—	—
4.8	S-8323A48MC-EMC-T2	—	—	—	—
5.0	S-8323A50MC-EME-T2	S-8323A50MA-EME-T2	S-8323A50UA-EME-T2	—	S-8323D50MC-E3E-T2
5.2	S-8323A52MC-EMG-T2	—	—	—	—

Output voltage (V)	S-8323HXXMC Series	S-8323JXXMC Series
2.5	—	S-8323J25MC-FQF-T2
3.0	S-8323H30MC-F4K-T2	S-8323J30MC-FQK-T2
3.3	S-8323H33MC-F4N-T2	S-8323J33MC-FQN-T2
4.8	S-8323H48MC-F5C-T2	—
5.0	S-8323H50MC-F5E-T2	S-8323J50MC-FRE-T2

Output voltage (V)	S-8327BXXMC Series	S-8327BXXMA Series	S-8327BXXUA Series	S-8327EXXMC Series
2.0	—	—	—	S-8327E20MC-EVA-T2
2.5	S-8327B25MC-ERF-T2	S-8327B25MA-ERF-T2	S-8327B25UA-ERF-T2	—
2.7	S-8327B27MC-ERH-T2	S-8327B27MA-ERH-T2	S-8327B27UA-ERH-T2	—
2.8	S-8327B28MC-ERI-T2	—	—	—
3.0	S-8327B30MC-ERK-T2	S-8327B30MA-ERK-T2	S-8327B30UA-ERK-T2	—
3.2	S-8327B32MC-ERM-T2	—	—	—
3.3	S-8327B33MC-ERN-T2	S-8327B33MA-ERN-T2	S-8327B33UA-ERN-T2	—
3.6	S-8327B36MC-ERQ-T2	—	—	—
4.8	S-8327B48MC-ESC-T2	—	—	—
5.0	S-8327B50MC-ESE-T2	S-8327B50MA-ESE-T2	S-8327B50UA-ESE-T2	S-8327E50MC-EKE-T2
5.2	S-8327B52MC-ESG-T2	—	—	—
5.4	S-8327B54MC-ESI-T2	—	—	—
5.6	—	—	—	—
6.0	S-8327B60MC-ESO-T2	—	—	—
7.0	—	—	—	S-8327E70MC-EKY-T2

Output voltage (V)	S-8327HXXMC Series	S-8327JXXMA Series
2.5	—	S-8327J25MC-F8F-T2
3.0	S-8327H30MC-FWK-T2	S-8327J30MC-F8K-T2
3.3	S-8327H33MC-FWN-T2	S-8327J33MC-F8N-T2
3.6	S-8327H36MC-FWQ-T2	—
5.0	S-8327H50MC-FXE-T2	S-8327J50MC-F9E-T2
5.2	S-8327H52MC-FXG-T2	—
5.6	S-8327H56MC-FXK-T2	—

Consult our sales person for products with an output voltage other than specified above.

■ **Pin Assignment**

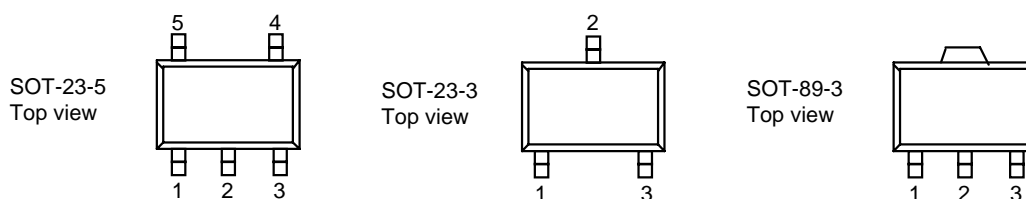

Figure 2

- S-8323AXXMC, S-8327BXXMC
 S-8323HXXMC/S-8327HXXMC
 SOT-23-5

Pin No.	Pin name	Functions
1	ON / OFF	Shutdown pin "H": normal operation (stepping up operation) "L": stop stepping up (whole circuit stop)
2	V _{OUT}	Output voltage pin and power supply pin
3	—	N.C. (Non Connection)
4	V _{SS}	GND pin
5	CONT	External inductor connection pin (for S-8323 Series)
	EXT	External transistor connection pin (for S-8327 Series)

- S-8323DXXMC, S-8327EXXMC
 S-8323JXXMC/S-8327JXXMC
 SOT-23-5

Pin No.	Pin name	Functions
1	V _{OUT}	Output voltage pin
2	V _{DD}	Power supply pin
3	—	N.C. (Non Connection)
4	V _{SS}	GND pin
5	CONT	External inductor connection pin (for S-8323 Series)
	EXT	External transistor connection pin (for S-8327 Series)

- S-8323AXXMA, S-8323AXXUA, S-8323CXXMA
 S-8327BXXMA, S-8327BXXUA
 SOT-23-3, SOT-89-3

Pin No.	Pin name	Functions
1	V _{SS}	GND pin
2	V _{OUT}	Output voltage pin and power supply pin
3	CONT	External inductor connection pin (for S-8323 Series)
	EXT	External transistor connection pin (for S-8327 Series)

■ **Absolute Maximum Ratings**

Note: Although the IC contains protection circuit against static electricity, excessive static electricity or voltage which exceeds the limit of the protection circuit should not be applied to.

(Unless otherwise specified: Ta=25°C)

Parameter	Symbol	Ratings	Unit
V _{OUT} , V _{DD} pin voltage	V _{OUT} , V _{DD}	11	V
ON/OFF pin voltage	ON/OFF	V _{SS} -0.3 to 11	V
CONT pin voltage	V _{CONT}	11	V
CONT pin current	I _{CONT}	300	mA
EXT pin voltage	V _{EXT}	V _{SS} -0.3 to V _{OUT} +0.3	V
EXT pin current	I _{EXT}	±50	mA
Power dissipation	PD	SOT-89-3	500
		SOT-23-5, SOT-23-3	150
Operating temperature	T _{OPR}	-40 to +85	°C
Storage temperature	T _{STG}	-40 to +125	°C

■ Electrical Characteristics

1-1. S-8323AXXMC

(Unless otherwise specified: Ta=25°C)

Parameter	Symbol	Conditions	Min.	Typ.	Max.	Unit	Test circuit	
Output voltage	V _{OUT}		S-8323A52MC	5.075	5.200	5.325	V	1
			S-8323A50MC	4.880	5.000	5.120		
			S-8323A33MC	3.221	3.300	3.379		
			S-8323A30MC	2.928	3.000	3.072		
			S-8323A27MC	2.635	2.700	2.765		
S-8323A25MC	2.440	2.500	2.560					
Input voltage	V _{IN}		—	—	9			
Operation start voltage	V _{ST1}	I _{OUT} =1mA	—	—	0.9			
Oscillation start voltage	V _{ST2}	No external parts, voltage applied to V _{OUT} CONT pulled up to 5 V by 10kΩ	—	—	0.8		2	
Operation holding voltage	V _{HLD}	I _{OUT} =1mA, Measured by decreasing V _{IN} voltage gradually	0.7	—	—		1	
Current consumption 1	I _{SS1}	V _{OUT} =output voltage×0.95	S-8323A52MC	—	31.6	52.6	μA	2
			S-8323A50MC	—	30.2	50.3		
			S-8323A33MC	—	19.1	31.8		
			S-8323A30MC	—	17.2	28.7		
			S-8323A27MC	—	15.5	25.9		
S-8323A25MC	—	14.3	23.9					
Current consumption 2	I _{SS2}	V _{OUT} =output voltage+0.5	S-8323A52MC	—	3.5	6.9	μA	2
			S-8323A50MC	—	3.5	6.9		
			S-8323A33MC	—	3.3	6.5		
			S-8323A30MC	—	3.2	6.4		
			S-8323A27MC	—	3.2	6.4		
S-8323A25MC	—	3.2	6.3					
Current consumption during shutdown	I _{SSS}	shutdown pin=0V	—	—	0.5			
Switching current	I _{SW}	V _{CONT} =0.4V	S-8323A52MC	114	182	—	mA	—
			S-8323A50MC	114	182	—		
			S-8323A33MC	78	125	—		
			S-8323A30MC	78	125	—		
			S-8323A27MC	61	98	—		
S-8323A25MC	61	98	—					
Switchin transistor leak current	I _{SWQ}	V _{OUT} = V _{CONT} =10V	—	—	1.0	μA	—	
Line regulation	ΔV _{OUT1}	V _{IN} =output voltage×0.4 to ×0.6	—	30	60	mV	1	
Load regulation	ΔV _{OUT2}	I _{OUT} =10μA to I _{OUT} (below) ×1.25	—	30	60			
Output voltage temperature coefficient	ΔV _{OUT} /ΔTa	Ta=-40°C to +85°C	S-8323A52MC	—	±0.26	—	mV/°C	1
			S-8323A50MC	—	±0.25	—		
			S-8323A33MC	—	±0.17	—		
			S-8323A30MC	—	±0.15	—		
			S-8323A27MC	—	±0.14	—		
S-8323A25MC	—	±0.13	—					
Oscillation frequency	f _{osc}	V _{OUT} =output voltage×0.95 Measured waveform at CONT pin	42.5	50	57.5	kHz	2	
Max. duty ratio	MaxDuty	V _{OUT} =output voltage×0.95 Measured waveform at CONT pin	75	83	90	%		
Shutdown pin Input voltage (ON/OFF type)	V _{SH}	V _{OUT} =output voltage×0.95 Judged the oscillation at CONT pin	0.75	—	—	V		
	V _{SL1}	V _{OUT} =output voltage×0.95 When V _{OUT} ≥1.5V	—	—	0.3			
	V _{SL2}	Judged the stop of oscillation at CONT pin When V _{OUT} <1.5V	—	—	0.2			
Soft start time	T _{SS}		3.0	6.0	12.0	ms	—	
Efficiency	EFF1		S-8323A52MC	—	87	—	%	1
			S-8323A50MC	—	87	—		
			S-8323A33MC	—	83	—		
			S-8323A30MC	—	83	—		
			S-8323A27MC	—	79	—		
S-8323A25MC	—	79	—					

External parts used:

- Coil: CD54 (100μH) of Sumida Electric Co., Ltd.
- Diode: MA720 (Schottky type) of Matsushita Electronic Components Co., Ltd.
- Capacitor: F93 (16V, 22μF, tantalum type) of Nichicon Corporation

Applied V_{IN}=output voltage×0.6, applied, I_{OUT}=output voltage/250Ω
The shutdown pin is connected to V_{OUT} pin.

Note 1: The output voltage specified above is the typical value.

SMALL PACKAGE PWM CONTROL STEP-UP SWITCHING REGULATOR

S-8323/8327 Series

Rev. 7.2

1-2. S-8323AXXMA, S-8323AXXUA, S-8323DXXMC

(Unless otherwise specified: Ta=25°C)

Parameter	Symbol	Conditions	Min.	Typ.	Max.	Unit	Test circuit	
Output voltage	V _{OUT}		S-8323X50XX	4.880	5.000	5.120	V	1
			S-8323X33XX	3.221	3.300	3.379		
			S-8323X30XX	2.928	3.000	3.072		
			S-8323X27XX	2.635	2.700	2.765		
			S-8323X25XX	2.440	2.500	2.560		
			S-8323X20XX	1.952	2.000	2.048		
Input voltage	V _{IN}		—	—	9			
Operation start voltage	V _{ST1}	I _{OUT} =1mA	—	—	0.9			
Oscillation start voltage	V _{ST2}	No external parts, voltage applied to V _{OUT} CONT pulled up to 5 V by 10Ω	—	—	0.8		2	
Operation holding voltage	V _{HLD}	I _{OUT} =1mA, Measured by decreasing V _{IN} voltage gradually.	0.7	—	—		1	
Current consumption 1	I _{SS1}	V _{OUT} =output voltage×0.95	S-8323X50XX	—	30.2	50.3	μA	2
			S-8323X33XX	—	19.1	31.8		
			S-8323X30XX	—	17.2	28.7		
			S-8323X27XX	—	15.5	25.9		
			S-8323X25XX	—	14.3	23.9		
			S-8323X20XX	—	11.6	19.4		
Current consumption 2	I _{SS2}	V _{OUT} =output voltage+0.5	S-8323X50XX	—	3.5	6.9	μA	2
			S-8323X33XX	—	3.3	6.5		
			S-8323X30XX	—	3.2	6.4		
			S-8323X27XX	—	3.2	6.4		
			S-8323X25XX	—	3.2	6.3		
			S-8323X20XX	—	3.1	6.2		
Switching current	I _{SW}	V _{CONT} =0.4V	S-8323X50XX	114	182	—	mA	—
			S-8323X33XX	78	125	—		
			S-8323X30XX	78	125	—		
			S-8323X27XX	61	98	—		
			S-8323X25XX	61	98	—		
			S-8323X20XX	45	71	—		
Switchin transistor leak current	I _{SWQ}	V _{OUT} = V _{CONT} =9V	—	—	1.0	μA		
Line regulation	ΔV _{OUT1}	V _{IN} = output voltage ×0.4 to ×0.6	—	30	60	mV		
Load regulation	ΔV _{OUT2}	I _{OUT} =10μA to I _{OUT} (below) ×1.25	—	30	60	mV		
Output voltage temperature coefficient	ΔV _{OUT} /ΔTa	Ta=-40°C to +85°C	S-8323X50XX	—	±0.25	—	mV/°C	1
			S-8323X33XX	—	±0.17	—		
			S-8323X30XX	—	±0.15	—		
			S-8323X27XX	—	±0.14	—		
			S-8323X25XX	—	±0.13	—		
			S-8323X20XX	—	±0.10	—		
Oscillation frequency	fosc	V _{OUT} =output voltage×0.95 Measured waveform at CONT pin	42.5	50	57.5	kHz	2	
Max.duty ratio	MaxDuty	V _{OUT} =output voltage×0.95 Measured waveform at CONT pin	75	83	90	%		
Soft start time	T _{SS}		3.0	6.0	12.0	ms	—	
Efficiency	EFFI		S-8323X50XX	—	87	—	%	2
			S-8323X33XX	—	83	—		
			S-8323X30XX	—	83	—		
			S-8323X27XX	—	79	—		
			S-8323X25XX	—	79	—		
			S-8323X20XX	—	75	—		

External parts used:

- Coil: CD54 (100μH) of Sumida Electric Co., Ltd.
- Diode: MA720 (Schottky type) of Matsushita Electronic Components Co., Ltd.
- Capacitor: F93 (16V, 22μF, tantalum type) of Nichicon Corporation

Applied V_{IN}=output voltage×0.6, I_{OUT}=output voltage/250Ω

The V_{DD} pin is connected to V_{OUT} pin for V_{DD}/V_{OUT} separate product.

Note 1: The output voltage specified above is the typical value.

Note 2: V_{DD}/V_{OUT} Separate products:

Boot operation is performed from V_{DD}=0.8V.

However, 2.0 V or more for V_{DD} is recommended to stabilize the output voltage and oscilation frequency.

SMALL PACKAGE PWM CONTROL STEP-UP SWITCHING REGULATOR

Rev. 7.2

S-8323/8327 Series

1-3. S-8323CXXMA

(Unless otherwise specified: Ta=25°C)

Parameter	Symbol	Conditions	Min.	Typ.	Max.	Unit	Test circuit	
Output voltage	V _{OUT}		S-8323C30MA	2.928	3.000	3.072	V	1
			S-8323C27MA	2.635	2.700	2.765		
			S-8323C25MA	2.440	2.500	2.560		
Input voltage	V _{IN}		—	—	9			
Operation start voltage	V _{ST1}	I _{OUT} =1mA	—	—	0.9			
Oscillation start voltage	V _{ST2}	No external parts, voltage applied to V _{OUT} CONT pulled up to 5 V by 10kΩ	—	—	0.8		2	
Operation holding voltage	V _{HLD}	I _{OUT} =1mA, Measured by decreasing V _{IN} voltage gradually.	0.7	—	—		1	
Current consumption 1	I _{SS1}	V _{OUT} =output voltage×0.95	S-8323C30MA	—	11.6	19.3	μA	2
			S-8323C27MA	—	10.5	17.5		
			S-8323C25MA	—	9.8	16.3		
Current consumption 2	I _{SS2}	V _{OUT} =output voltage+0.5	S-8323C30MA	—	3.0	5.9	μA	2
			S-8323C27MA	—	2.9	5.8		
			S-8323C25MA	—	2.9	5.8		
Switching current	I _{SW}	V _{CONT} =0.4V	S-8323C30MA	78	125	—	mA	—
			S-8323C27MA	61	98	—		
			S-8323C25MA	61	98	—		
Switching transistor leak current	I _{SWQ}	V _{OUT} = V _{CONT} =9V	—	—	1.0	μA		
Line regulation	ΔV _{OUT1}	V _{IN} = output voltage ×0.4 to ×0.6	—	30	60	mV	1	
Load regulation	ΔV _{OUT2}	I _{OUT} =10μA to I _{OUT} (below) ×1.25	—	30	60	mV		
Output voltage temperature coefficient	ΔV _{OUT} /ΔTa	Ta=-40°C to +85°C	—	±0.15	—	mV/°C		
Output voltage temperature coefficient	ΔV _{OUT} /ΔTa	Ta=-40°C to +85°C	S-8323C30MA	—	±0.15	—	mV/°C	1
			S-8323C27MA	—	±0.14	—		
			S-8323C25MA	—	±0.13	—		
Oscillation frequency	fosc	V _{OUT} =output voltage×0.95 Measured waveform at CONT pin	25	30	35	kHz	2	
Max. duty ratio	MaxDuty	V _{OUT} =output voltage×0.95 Measured waveform at CONT pin	75	83	90	%		
Soft start time	T _{SS}		3.0	6.0	12.0	ms	—	
Efficiency	EFF1		S-8323C30MA	—	81	—	%	2
			S-8323C27MA	—	77	—		
			S-8323C25MA	—	77	—		

External parts used:

- Coil: CD54 (100μH) of Sumida Electric Co., Ltd.
- Diode: MA720 (Schottky type) of Matsushita Electronic Components Co., Ltd.
- Capacitor: F93 (16V, 22μF, tantalum type) of Nichicon Corporation

Applied V_{IN}=output voltage×0.6, I_{OUT}=output voltage/250Ω

Note 1: The output voltage specified above is the typical value of the output voltage.

SMALL PACKAGE PWM CONTROL STEP-UP SWITCHING REGULATOR
S-8323/8327 Series

Rev. 7.2

1-4. S-8323HXXMC

(Unless otherwise specified: Ta=25°C)

Parameter	Symbol	Conditions	Min.	Typ.	Max.	Unit	Test circuit		
Output voltage	V _{OUT}		S-8323H33MC	3.221	3.300	3.379	V	1	
			S-8323H50MC	4.880	5.000	5.120			
Input voltage	V _{IN}		—	—	9	V			2
Operation start voltage	V _{ST1}	I _{OUT} =1mA	—	—	1.4				
Oscillation start voltage	V _{ST2}	No external parts, voltage applied to V _{OUT} CONT pulled up to 5 V by 10kΩ	—	—	1.3				
Operation holding voltage	V _{HLD}	I _{OUT} =1mA, Measured by decreasing V _{IN} voltage gradually	0.7	—	—	μA	1		
Current consumption 1		V _{OUT} =output voltage×0.95	S-8323H33MC	—	87.9	146.5	μA	2	
Current consumption 2	I _{SS2}	V _{OUT} =output voltage+0.5	S-8323H50MC	—	142.6	237.7			
			S-8323H33MC	—	10.0	19.9			
			S-8323H50MC	—	10.2	20.3			
Current consumption during shutdown	I _{SSS}	shutdown pin=0V	—	—	0.5	mA	—		
Switching current	I _{SW}	V _{CONT} =0.4V	S-8323H33MC	78	125	—	mA	—	
			S-8323H50MC	114	182	—			
Switchin transistor leak current	I _{SWQ}	V _{OUT} = V _{CONT} =10V	—	—	1.0	μA	—		
Line regulation	ΔV _{OUT1}	V _{IN} =output voltage×0.4 to ×0.6	—	30	60	mV	1		
Load regulation	ΔV _{OUT2}	I _{OUT} =10μA to I _{OUT} (below) ×1.25	—	30	60	mV/°C			
Output voltage temperature coefficient	ΔV _{OUT} /ΔTa	Ta=-40°C to +85°C	S-8323H33MC	—	±0.17	—			
Oscillation frequency	fosc	V _{OUT} =output voltage×0.95 Measured waveform at CONT pin	S-8323H50MC	212.5	250	287.5	kHz	2	
			S-8323H33MC	—	—	—			
Max. duty ratio	MaxDuty	V _{OUT} =output voltage×0.95 Measured waveform at CONT pin	70	78	85	%	—		
Shutdown pin Input voltage (ON/OFF type)	V _{SH}	V _{OUT} =output voltage×0.95 Judged the oscillation at CONT pin	0.75	—	—	V	2		
	V _{SL1}	V _{OUT} =output voltage×0.95 When V _{OUT} ≥1.5V	—	—	0.3				
	V _{SL2}	Judged the stop of oscillation at CONT pin When V _{OUT} <1.5V	—	—	0.2				
Soft start time	T _{SS}		1.8	3.6	7.2	ms	—		
Efficiency	EFFI		S-8323H33MC	—	83	—	%	1	
			S-8323H50MC	—	87	—			

External parts used:

- Coil: CD54 (22μH) of Sumida Electric Co., Ltd.
- Diode: MA720 (Schottky type) of Matsushita Electronic Components Co., Ltd.
- Capacitor: F93 (16V, 22μF, tantalum type) of Nichicon Corporation

Applied V_{IN}=output voltage×0.6, applied, I_{OUT}=output voltage/250Ω
 The shutdown pin is connected to V_{OUT} pin.

Note 1: The output voltage specified above is the typical value.

SMALL PACKAGE PWM CONTROL STEP-UP SWITCHING REGULATOR

Rev. 7.2

S-8323/8327 Series

1-5. S-8323JXXMC

(Unless otherwise specified: Ta=25°C)

Parameter	Symbol	Conditions	Min.	Typ.	Max.	Unit	Test circuit	
Output voltage	V _{OUT}							
			S-8323J25MC	2.440	2.500	2.560	V	1
			S-8323J50MC	4.880	5.000	5.120		
Input voltage	V _{IN}		—	—	9			
Operation start voltage	V _{ST1}	I _{OUT} =1mA	—	—	1.4			
Oscillation start voltage	V _{ST2}	No external parts, voltage applied to V _{OUT} CONT pulled up to 5 V by 10Ω	—	—	1.3		2	
Operation holding voltage	V _{HLD}	I _{OUT} =1mA, Measured by decreasing V _{IN} voltage gradually.	0.7	—	—		1	
Current consumption 1	I _{SS1}	V _{OUT} =output voltage×0.95				μA	2	
			S-8323J25MC	—	64.8			108.0
			S-8323J50MC	—	142.6	237.7		
Current consumption 2	I _{SS2}	V _{OUT} =output voltage+0.5				μA	2	
			S-8323J25MC	—	9.9			19.7
			S-8323J50MC	—	10.2	20.3		
Switching current	I _{SW}	V _{CONT} =0.4V				mA	—	
			S-8323J25MC	61	98			—
			S-8323J50MC	114	182	—		
Switchin transistor leak current	I _{SWQ}	V _{OUT} = V _{CONT} =9V	—	—	1.0	μA		
Line regulation	ΔV _{OUT1}	V _{IN} = output voltage ×0.4 to ×0.6	—	30	60	mV	1	
Load regulation	ΔV _{OUT2}	I _{OUT} =10μA to I _{OUT} (below) ×1.25	—	30	60			
Output voltage temperature coefficient	ΔV _{OUT} /ΔTa	Ta=-40°C to +85°C				mV/°C	1	
			S-8323J25MC	—	±0.13			—
			S-8323J50MC	—	±0.25	—		
Oscillation frequency	fosc	V _{OUT} =output voltage×0.95 Measured waveform at CONT pin	212.5	250	287.5	kHz	2	
Max.duty ratio	MaxDuty	V _{OUT} =output voltage×0.95 Measured waveform at CONT pin	70	78	85			%
Soft start time	T _{SS}		1.8	3.6	7.2	ms	—	
Efficiency	EFFI					%	2	
			S-8323J25MC	—	79			—
			S-8323J50MC	—	87	—		

External parts used:

- Coil: CD54 (22μH) of Sumida Electric Co., Ltd.
- Diode: MA720 (Schottky type) of Matsushita Electronic Components Co., Ltd.
- Capacitor: F93 (16V, 22μF, tantalum type) of Nichicon Corporation

Applied V_{IN}=output voltage×0.6, I_{OUT}=output voltage/250Ω

The V_{DD} pin is connected to V_{OUT} pin for V_{DD}/V_{OUT} separate product.

Note 1: The output voltage specified above is the typical value.

Note 2: V_{DD}/V_{OUT} Separate products:

Boot operation is performed from V_{DD}=0.8V.

However, 2.0 V or more for V_{DD} is recommended to stabilize the output voltage and oscilation frequency.

However, accuracy of output volutage is degraded to ±4% under the V_{DD} voltage between 2.0V to 2.35V.

SMALL PACKAGE PWM CONTROL STEP-UP SWITCHING REGULATOR

S-8323/8327 Series

Rev. 7.2

2-1. S-8327BXXMC

(Unless otherwise specified: Ta=25°C)

Parameter	Symbol	Conditions	Min.	Typ.	Max.	Unit	Test circuit	
Output voltage	V _{OUT}		S-8327B54MC	5.270	5.400	5.530	V	3
			S-8327B50MC	4.880	5.000	5.120		
			S-8327B36MC	3.514	3.600	3.686		
			S-8327B33MC	3.221	3.300	3.379		
			S-8327B30MC	2.928	3.000	3.072		
			S-8327B28MC	2.733	2.800	2.867		
			S-8327B27MC	2.635	2.700	2.765		
Input voltage	V _{IN}		—	—	9			
Operation start voltage	V _{ST1}	I _{OUT} =1mA	—	—	0.9			
Oscillation start voltage	V _{ST2}	No external parts, voltage applied to V _{OUT}	—	—	0.8		4	
Operation holding voltage	V _{HLD}	I _{OUT} =1mA, Measured by decreasing V _{IN} voltage gradually.	0.7	—	—		3	
Current consumption 1	I _{SS1}	V _{OUT} =output voltage×0.95	S-8327B54MC	—	41.0	68.3	μA	4
			S-8327B50MC	—	37.6	62.6		
			S-8327B36MC	—	26.0	43.3		
			S-8327B33MC	—	23.7	39.5		
			S-8327B30MC	—	21.4	35.7		
			S-8327B28MC	—	20.0	33.3		
			S-8327B27MC	—	19.2	32.0		
Current consumption 2	I _{SS2}	V _{OUT} =output voltage+0.5	S-8327B54MC	—	4.2	8.3	μA	4
			S-8327B50MC	—	4.2	8.3		
			S-8327B36MC	—	4.0	7.9		
			S-8327B33MC	—	4.0	7.9		
			S-8327B30MC	—	3.9	7.8		
			S-8327B28MC	—	3.9	7.8		
			S-8327B27MC	—	3.9	7.7		
Current consumption while shutdown	I _{SSS}	shutdown pin=0V	—	—	0.5			
EXT pin output current	I _{EXTH}	V _{EXT} =V _{OUT} -0.4V	S-8327B54MC	-5.3	-8.0	—	mA	—
			S-8327B50MC	-5.3	-8.0	—		
			S-8327B36MC	-3.5	-5.3	—		
			S-8327B33MC	-3.5	-5.3	—		
			S-8327B30MC	-3.5	-5.3	—		
			S-8327B28MC	-2.7	-4.0	—		
			S-8327B27MC	-2.7	-4.0	—		
	S-8327B25MC	-2.7	-4.0	—				
	I _{EXTL}	V _{EXT} =0.4V	S-8327B54MC	10.7	16.0	—		
			S-8327B50MC	10.7	16.0	—		
			S-8327B36MC	7.0	10.5	—		
			S-8327B33MC	7.0	10.5	—		
			S-8327B30MC	7.0	10.5	—		
			S-8327B28MC	5.3	8.0	—		
S-8327B27MC			5.3	8.0	—			
Line regulation	ΔV _{OUT1}	V _{IN} =output voltage×0.4 to ×0.6	—	30	60	mV		
Load regulation	ΔV _{OUT2}	I _{OUT} =10μA to I _{OUT} (below) ×1.25	—	30	60			
Output voltage temperature coefficient	ΔV _{OUT} /ΔTa	Ta=-40°C to +85°C	S-8327B54MC	—	±0.27	—	mV/°C	3
			S-8327B50MC	—	±0.25	—		
			S-8327B36MC	—	±0.18	—		
			S-8327B33MC	—	±0.17	—		
			S-8327B30MC	—	±0.15	—		
			S-8327B28MC	—	±0.14	—		
			S-8327B27MC	—	±0.14	—		
Oscillation frequency	f _{osc}	V _{OUT} =output voltage×0.95 Measure waveform at EXT pin	85	100	115	kHz		
Max. duty ratio	MaxDuty	V _{OUT} =output voltage×0.95 Measure waveform at EXT pin	75	83	90	%		
Shutdown pin Input voltage	V _{SH}	V _{OUT} =output voltage×0.95 Measure the oscillation at EXT pin	0.75	—	—	V	4	
	V _{SL1}	V _{OUT} =output voltage×0.95 When V _{OUT} ≥1.5V	—	—	0.3			
	V _{SL2}	Judged the stop of oscillation at EXT pin When V _{OUT} <1.5V	—	—	0.2			
Soft start time	T _{SS}		3.0	6.0	12.0	ms		
Efficiency	EFF1		S-8327B54MC	—	88	—	%	3
			S-8327B50MC	—	88	—		
			S-8327B36MC	—	84	—		
			S-8327B33MC	—	84	—		
			S-8327B30MC	—	84	—		
			S-8327B28MC	—	80	—		
			S-8327B27MC	—	80	—		

External parts used:

- Coil: CD54 (47μH) of Sumida Electric Co., Ltd.
- Diode: MA720 (Schottky type) of Matsushita Electronic Components Co., Ltd.
- Capacitor: F93 (16V, 47μF, tantalum type) of Nichicon Corporation
- Transistor: 2SD1628G of Sanyo Electronics
- Base Resistance (Rb): 1.0kΩ
- Base Capacitor (Cb): 2200 pF (ceramic)

Applied V_{IN}=output voltage×0.6, I_{OUT}=output voltage/50Ω
The shutdown pin is connected to V_{OUT} pin.

Note 1: The output voltage specified above is the typical value.

SMALL PACKAGE PWM CONTROL STEP-UP SWITCHING REGULATOR

Rev. 7.2

S-8323/8327 Series

2-2. S-8327BXXMA, S-8327BXXUA, S-8327EXXMC

(Unless otherwise specified: Ta=25°C)

Parameter	Symbol	Conditions	Min.	Typ.	Max.	Unit	Test circuit	
Output voltage	V _{OUT}		S-8327X50XX	4.880	5.000	5.120	V	3
			S-8327X33XX	3.221	3.300	3.379		
			S-8327X30XX	2.928	3.000	3.072		
			S-8327X27XX	2.635	2.700	2.765		
			S-8327X25XX	2.440	2.500	2.560		
			S-8327X20XX	1.952	2.000	2.048		
Input voltage	V _{IN}		—	—	9			
Operation start voltage	V _{ST1}	I _{OUT} =1mA	—	—	0.9			
Oscillation start voltage	V _{ST2}	No external parts, voltage applied to V _{OUT}	—	—	0.8		4	
Operation holding voltage	V _{HLD}	I _{OUT} =1mA, Measured by decreasing V _{IN} voltage gradually B.	0.7	—	—		3	
Current consumption 1	I _{SS1}	V _{OUT} =output voltage×0.95	S-8327X50XX	—	37.6	62.6	μA	4
			S-8327X33XX	—	23.7	39.5		
			S-8327X30XX	—	21.4	35.7		
			S-8327X27XX	—	19.2	32.0		
			S-8327X25XX	—	17.8	29.7		
			S-8327X20XX	—	14.5	24.1		
Current consumption 2	I _{SS2}	V _{OUT} =output voltage+0.5	S-8327X50XX	—	4.2	8.3		
			S-8327X33XX	—	4.0	7.9		
			S-8327X30XX	—	3.9	7.8		
			S-8327X27XX	—	3.9	7.7		
			S-8327X25XX	—	3.9	7.7		
			S-8327X20XX	—	3.8	7.6		
EXT pin output current	I _{EXTH}	V _{EXT} =V _{OUT} -0.4V	S-8327X50XX	-5.3	-8.0	—	mA	—
			S-8327X33XX	-3.5	-5.3	—		
			S-8327X30XX	-3.5	-5.3	—		
			S-8327X27XX	-2.7	-4.0	—		
			S-8327X25XX	-2.7	-4.0	—		
			S-8327X20XX	-1.9	-2.9	—		
	I _{EXTL}	V _{EXT} =-0.4V	S-8327X50XX	10.7	16.0	—		
			S-8327X33XX	7.0	10.5	—		
			S-8327X30XX	7.0	10.5	—		
			S-8327X27XX	5.3	8.0	—		
			S-8327X25XX	5.3	8.0	—		
			S-8327X20XX	3.8	5.7	—		
Line regulation	ΔV _{OUT1}	V _{IN} =output voltage×0.4 to ×0.6	—	30	60	mV		
Load regulation	ΔV _{OUT2}	I _{OUT} =10μA to I _{OUT} (below) ×1.25	—	30	60			
Output voltage temperature coefficient	ΔV _{OUT} /ΔTa	Ta=-40°C to +85°C	S-8327X50XX	—	±0.25	—	mV/°C	3
			S-8327X33XX	—	±0.17	—		
			S-8327X30XX	—	±0.15	—		
			S-8327X27XX	—	±0.14	—		
			S-8327X25XX	—	±0.13	—		
			S-8327X20XX	—	±0.10	—		
Oscillation frequency	f _{osc}	V _{OUT} =output voltage×0.95 Measured waveform at EXT pin	85	100	115	kHz		
Max. duty ratio	MaxDuty	V _{OUT} =output voltage×0.95 Measured waveform at EXT pin	75	83	90	%	4	
Soft start time	T _{SS}		3.0	6.0	12.0	ms	—	
Efficiency	EFFI		S-8327X50XX	—	88	—	%	3
			S-8327X33XX	—	84	—		
			S-8327X30XX	—	84	—		
			S-8327X27XX	—	80	—		
			S-8327X25XX	—	80	—		
			S-8327X20XX	—	76	—		

External parts used:

- Coil: CD54 (47μH) of Sumida Electric Co., Ltd.
- Diode: MA720 (Schottky type) of Matsushita Electronic Components Co., Ltd.
- Capacitor: F93 (16V, 47μF, tantalum type) of Nichicon Corporation
- Transistor: 2SD1628G of Sanyo Electronics
- Base resistor (Rb): 1.0KΩ
- Base capacitor (Cb): 2200pF (ceramic)

Applied V_{IN}=output voltage×0.6, I_{OUT}=output voltage/50Ω

The V_{DD} pin is connected to V_{OUT} pin for V_{DD}/V_{OUT} separate product.

Note 1: The output voltage specified above is the typical value.

Note 2: V_{DD}/V_{OUT} Separate products:

Boot operation is performed from V_{DD}=0.8V.

However, 2.0 V or more for V_{DD} is recommended to stabilize the output voltage and oscillation frequency.

SMALL PACKAGE PWM CONTROL STEP-UP SWITCHING REGULATOR

S-8323/8327 Series

Rev. 7.2

2-3. S-8327HXXMC

(Unless otherwise specified: Ta=25°C)

Parameter	Symbol	Conditions	Min.	Typ.	Max.	Unit	Test circuit	
Output voltage	V _{OUT}		S-8327H30MC	2.928	3.000	3.072	V	3
			S-8327H33MC	3.221	3.300	3.379		
			S-8327H50MC	4.880	5.000	5.120		
Input voltage	V _{IN}		—	—	9			
Operation start voltage	V _{ST1}	I _{OUT} =1mA	—	—	1.4		4	
Oscillation start voltage	V _{ST2}	No external parts, voltage applied to V _{OUT}	—	—	1.3		3	
Operation holding voltage	V _{HLD}	I _{OUT} =1mA, Measured by decreasing V _{IN} voltage gradually.	0.7	—	—			
Current consumption 1	I _{SS1}	V _{OUT} =output voltage×0.95	S-8327H30MC	—	53.9	89.8	μA	4
			S-8327H33MC	—	59.4	99.0		
			S-8327H50MC	—	93.7	156.1		
Current consumption 2	I _{SS2}	V _{OUT} =output voltage+0.5	S-8327H30MC	—	10.0	19.9	μA	4
			S-8327H33MC	—	10.0	19.9		
			S-8327H50MC	—	10.2	20.3		
Current consumption while shutdown	I _{SS3}	shutdown pin=0V	—	—	0.5			
EXT pin output current	I _{EXTH}	V _{EXT} =V _{OUT} -0.4V	S-8327H30MC	-3.5	-5.3	—	mA	—
			S-8327H33MC	-3.5	-5.3	—		
			S-8327H50MC	-5.3	-8.0	—		
	I _{EXTL}	V _{EXT} =0.4V	S-8327H30MC	7.0	10.5	—	mA	—
			S-8327H33MC	7.0	10.5	—		
S-8327H50MC	10.7	16.0	—					
Line regulation	ΔV _{OUT1}	V _{IN} =output voltage×0.4 to ×0.6	—	30	60	mV	3	
Load regulation	ΔV _{OUT2}	I _{OUT} =10μA to I _{OUT} (below) ×1.25	—	30	60	mV		
Output voltage temperature coefficient	ΔV _{OUT} /ΔTa	Ta=-40°C to +85°C	S-8327H30MC	—	±0.15	—	mV/°C	
			S-8327H33MC	—	±0.17	—		
			S-8327H50MC	—	±0.25	—		
Oscillation frequency	fosc	V _{OUT} =output voltage×0.95 Measure waveform at EXT pin	212.5	250	287.5	kHz		
Max. duty ratio	MaxDuty	V _{OUT} =output voltage×0.95 Measure waveform at EXT pin	70	78	85	%	4	
Shutdown pin Input voltage (ON/OFF type)	V _{SH}	V _{OUT} =output voltage×0.95	0.75	—	—	V	4	
	V _{SL1}	V _{OUT} =output voltage×0.95	—	—	0.3			
	V _{SL2}	V _{OUT} =output voltage×0.95	—	—	0.2			
Soft start time	T _{SS}		1.5	3.0	6.0	ms	—	
Efficiency	EFF1		S-8327H30MC	—	81	—	%	3
			S-8327H33MC	—	81	—		
			S-8327H50MC	—	85	—		

External parts used:

- Coil: CD54 (22μH) of Sumida Electric Co., Ltd.
- Diode: MA720 (Schottky type) of Matsushita Electronic Components Co., Ltd.
- Capacitor: F93 (16V, 47μF, tantalum type) of Nichicon Corporation
- Transistor: NDS355AN of National Semiconductor

Applied V_{IN}=output voltage×0.6, I_{OUT}=output voltage/50Ω

The shutdown pin is connected to V_{OUT} pin.

Note 1: The output voltage specified above is the typical value.

SMALL PACKAGE PWM CONTROL STEP-UP SWITCHING REGULATOR

Rev. 7.2

S-8323/8327 Series

2-4. S-8327JXXMC

(Unless otherwise specified: Ta=25°C)

Parameter	Symbol	Conditions	Min.	Typ.	Max.	Unit	Test circuit	
Output voltage	V _{OUT}		S-8327H25MC	2.440	2.500	2.560	V	3
			S-8327H50MC	4.880	5.000	5.120		
Input voltage	V _{IN}		—	—	9			
Operation start voltage	V _{ST1}	I _{OUT} =1mA	—	—	1.4			
Oscillation start voltage	V _{ST2}	No external parts, voltage applied to V _{OUT}	—	—	1.3		4	
Operation holding voltage	V _{HLD}	I _{OUT} =1mA, Measured by decreasing V _{IN} voltage gradually B.	0.7	—	—		3	
Current consumption 1	I _{SS1}	V _{OUT} =output voltage×0.95	S-8327H25MC	—	44.9	74.8	μA	4
			S-8327H50MC	—	93.7	156.1		
Current consumption 2	I _{SS2}	V _{OUT} =output voltage+0.5	S-8327H25MC	—	9.9	19.7		
			S-8327H50MC	—	10.2	20.3		
EXT pin output current	I _{EXTH}	V _{EXT} =V _{OUT} -0.4V	S-8327H25MC	-2.7	-4.0	—	mA	—
			S-8327H50MC	-5.3	-8.0	—		
	I _{EXTL}	V _{EXT} =-0.4V	S-8327H25MC	5.3	8.0	—		
			S-8327H50MC	10.7	16.0	—		
Line regulation	ΔV _{OUT1}	V _{IN} =output voltage×0.4 to ×0.6	—	30	60	mV	3	
Load regulation	ΔV _{OUT2}	I _{OUT} =10μA to I _{OUT} (below) ×1.25	—	30	60			
Output voltage temperature coefficient	ΔV _{OUT} /ΔTa	Ta=-40°C to +85°C	S-8327H25MC	—	±0.13	—	mV/°C	3
			S-8327H50MC	—	±0.25	—		
Oscillation frequency	fosc	V _{OUT} =output voltage×0.95 Measured waveform at EXT pin	212.5	250	287.5	kHz	4	
Max. duty ratio	MaxDuty	V _{OUT} =output voltage×0.95 Measured waveform at EXT pin	70	78	85	%		
Soft start time	T _{SS}		1.5	3.0	6.0	ms	—	
Efficiency	EFFI		S-8327H25MC	—	77	—	%	3
			S-8327H50MC	—	85	—		

External parts used:

- Coil: CD54 (22μH) of Sumida Electric Co., Ltd.
- Diode: MA720 (Schottky type) of Matsushita Electronic Components Co., Ltd.
- Capacitor: F93 (16V, 47μF, tantalum type) of Nichicon Corporation
- Transistor: NDS355AN of National Semiconductor

Applied V_{IN}=output voltage×0.6, I_{OUT}=output voltage/50Ω

The V_{DD} pin is connected to V_{OUT} pin for V_{DD}/V_{OUT} separate product.

Note 1: The output voltage specified above is the typical value.

Note 2: V_{DD}/V_{OUT} Separate products:

Boot operation is performed from V_{DD}=0.8V.

However, 2.0 V or more for V_{DD} is recommended to stabilize the output voltage and oscillation frequency.

However, accuracy of output voltage is degraded to ±4% under the V_{DD} voltage between 2.0V to 2.35V.

■ **Test Circuits**

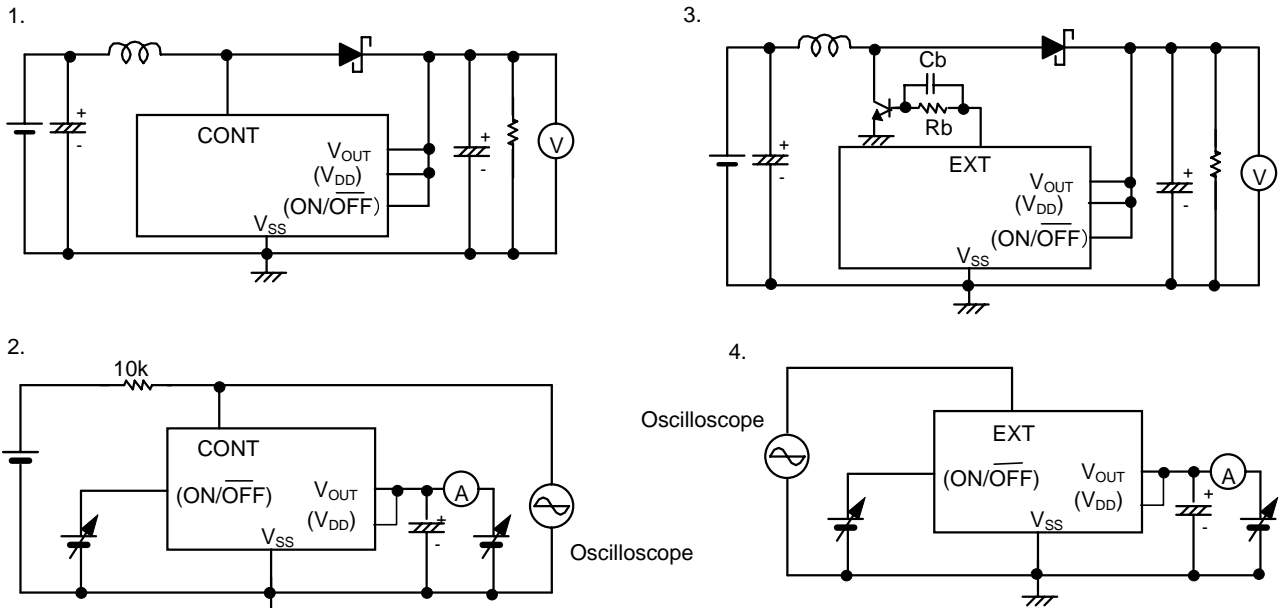

Figure 3

■ **Operation**

1. Step-Up DC/DC Converter

The S-8323/8327 Series is a step-up switching regulator using a pulse width modulation method (PWM) and DC/DC converter and features a low current consumption.

In conventional PFM DC/DC converters, pulses are skipped at low output load current, causing fluctuation in ripple frequency of the output voltage, with the result of increase in ripple voltage.

In S-8323/27 series the switching frequency does not change, although the pulse width changes from 0% to 83%(78% for H, J types) corresponding to each load current.

The ripple voltage generated from switching can be removed easily through the filter because the switching frequency is constant.

The built-in soft start circuit controls a rush current and overshoot of the output voltage when powering on or the ON/OFF terminal turns to 'H' level.

Shutdown pin: Stops or starts step-up operation.
 (Only for SOT-23-5 package products of A, B, and H Series.)

Turning the shutdown pin low stops operation of all the internal circuits and reduces current consumption significantly. DO NOT use the shutdown pin in floating state because it has a structure shown in Figure 4 and is not pulled up or pulled down internally. DO NOT apply voltage of between 0.3 V and 0.75 V to the shutdown pin because applying such voltage increases the current consumption. If the shutdown pin is not used, connect it to V_{OUT} (V_{DD} for D, E, J types) pin. The shutdown pin doesn't have hysteresis.

Shutdown pin	CR oscillation circuit	Output voltage
"H"	Operation	Fixed
"L"	Stop	$\cong V_{IN}^*$

* Voltage obtained by extracting the voltage drop due to DC resistance of the inductor and the diode forward voltage from V_{IN} .

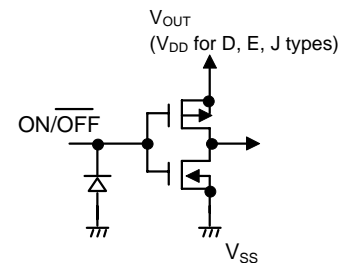

Figure 4

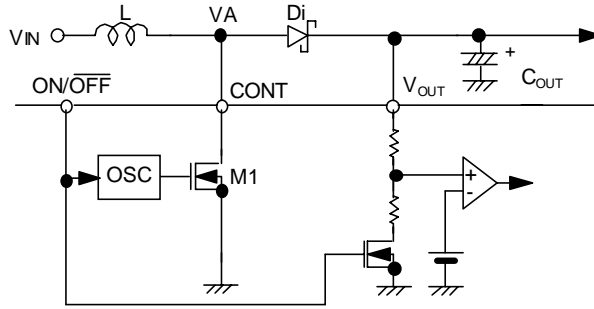

Figure 5

The following are basic equations [(1) through (7)] of the step-up switching regulator (see Figure 5.)

Voltage at CONT pin the moment M1 is turned ON (current I_L flowing through L is zero):

$$V_A = V_S \dots\dots\dots (1)$$

(V_S : Non-saturated voltage of M1)

The change in I_L over time:

$$\frac{dI_L}{dt} = \frac{V_L}{L} = \frac{V_{IN} - V_S}{L} \dots\dots\dots (2)$$

Integration of the above equation (I_L):

$$I_L = \left(\frac{V_{IN} - V_S}{L} \right) \cdot t \dots\dots\dots (3)$$

I_L flows while M1 is ON (t_{ON}). The time of t_{ON} is determined by the oscillation frequency of the OSC.

The peak current (I_{PK}) after t_{ON} :

$$I_{PK} = \left(\frac{V_{IN} - V_S}{L} \right) \cdot t_{ON} \dots\dots\dots (4)$$

The energy stored in L is represented with $1/2 \cdot L \cdot (I_{PK})^2$.

When M1 is turned OFF (t_{OFF}), the energy stored in L is transmitted through a diode to the output capacitor. Then reverse voltage (V_L) is generated.

$$V_L = (V_{OUT} + V_D) - V_{IN} \dots\dots\dots (5)$$

(V_D : Diode forward voltage)

The voltage at CONT pin rises only by the voltage corresponding to $V_{OUT} + V_D$.

The change in the current flowing through the diode into V_{OUT} during t_{OFF} :

$$\frac{dI_L}{dt} = \frac{V_L}{L} = \frac{V_{OUT} + V_D - V_{IN}}{L} \dots\dots\dots (6)$$

Integration of the above equation is as follows:

$$I_L = I_{PK} - \left(\frac{V_{OUT} + V_D - V_{IN}}{L} \right) \cdot t \dots\dots\dots (7)$$

During t_{ON} , the energy is stored in L and is not transmitted to V_{OUT} . When receiving output current (I_{OUT}) from V_{OUT} , the energy of the capacitor (C_{OUT}) is consumed. As a result, the pin voltage of C_{OUT} is reduced, and goes to the lowest level after M1 is turned ON (t_{ON}). When M1 is turned OFF, the energy stored in L is transmitted through the diode to C_{OUT} , and the voltage of C_{OUT} rises drastically. V_{OUT} is a time function that indicates the maximum value (ripple voltage: V_{P-P}) when the current flowing through the diode into V_{OUT} and load current (I_{OUT}) match.

Next, the ripple voltage is found out as follows:

I_{OUT} vs t_1 (time) from when M1 is turned OFF (after t_{ON}) to when V_{OUT} reaches the maximum level:

$$I_{OUT} = I_{PK} - \left(\frac{V_{OUT} + V_D - V_{IN}}{L} \right) \cdot t_1 \dots\dots\dots (8)$$

$$\therefore t_1 = (I_{PK} - I_{OUT}) \cdot \left(\frac{L}{V_{OUT} + V_D - V_{IN}} \right) \dots\dots\dots (9)$$

When M1 is turned ON (after t_{OFF}), $I_L = 0$ (when the energy of the inductor is completely transmitted). Based on equation (7),

$$\left(\frac{L}{V_{OUT} + V_D - V_{IN}} \right) = \frac{t_{OFF}}{I_{PK}} \dots\dots\dots (10)$$

When substituting equation (10) for equation (9),

$$t_1 = t_{OFF} - \left(\frac{I_{OUT}}{I_{PK}} \right) \cdot t_{OFF} \dots\dots\dots (11)$$

Electric charge ΔQ_1 which is charged in C_{OUT} during t_1 :

$$\begin{aligned} \Delta Q_1 &= \int_0^{t_1} I_L dt = I_{PK} \cdot \int_0^{t_1} dt - \frac{V_{OUT} + V_D - V_{IN}}{L} \cdot \int_0^{t_1} t dt \\ &= I_{PK} \cdot t_1 - \frac{V_{OUT} + V_D - V_{IN}}{L} \cdot \frac{1}{2} t_1^2 \dots\dots\dots (12) \end{aligned}$$

When substituting equation (12) for equation (9):

$$\Delta Q_1 = I_{PK} - \frac{1}{2} (I_{PK} - I_{OUT}) \cdot t_1 = \frac{I_{PK} + I_{OUT}}{2} \cdot t_1 \dots\dots\dots (13)$$

A rise in voltage (V_{P-P}) due to ΔQ_1 :

$$V_{P-P} = \frac{\Delta Q_1}{C_{OUT}} = \frac{1}{C_{OUT}} \cdot \left(\frac{I_{PK} + I_{OUT}}{2} \right) \cdot t_1 \dots\dots\dots (14)$$

When taking into consideration I_{OUT} to be consumed during t_1 and ESR (Equivalent Series Resistance) of C_{OUT} , namely R_{ESR} :

$$V_{P-P} = \frac{\Delta Q_1}{C_{OUT}} = \frac{1}{C_{OUT}} \cdot \left(\frac{I_{PK} + I_{OUT}}{2} \right) \cdot t_1 + \left(\frac{I_{PK} + I_{OUT}}{2} \right) \cdot R_{ESR} - \frac{I_{OUT} \cdot t_1}{C_{OUT}} \dots\dots\dots (15)$$

When substituting equation (11) for equation (15):

$$V_{P-P} = \frac{(I_{PK} - I_{OUT})^2}{2I_{PK}} \cdot \frac{t_{OFF}}{C_{OUT}} + \left(\frac{I_{PK} + I_{OUT}}{2} \right) \cdot R_{ESR} \dots\dots\dots (16)$$

Therefore to reduce the ripple voltage, it is important that the capacitor connected to the output pin has a large capacity and a small ESR.

■ External parts selection for DC-DC converter

The relationship between major characteristics of the step-up circuit and characteristics parameters of the external parts are shown in Figure 6.

for large output current?	for high efficiency?		for small ripple voltage
	operation efficiency	stand-by efficiency	
small inductance	large inductance		
small DC resistance of inductor			
			large output capacitance
external switching transistor (small ON resistance)	built-in switching transistor		
small resistance of external resistor Rb when an external switching transistor is used	large resistance of external resistor Rb when an external switching transistor is used.		

Figure 6 Relationship between major characteristics of the step-up circuit and external parts

1. Inductor

An inductance has strong influence on max. output current I_{OUT} and efficiency η .

Figure 7 shows I_{OUT} η characteristics for inductance of S-8323 and S-8327.

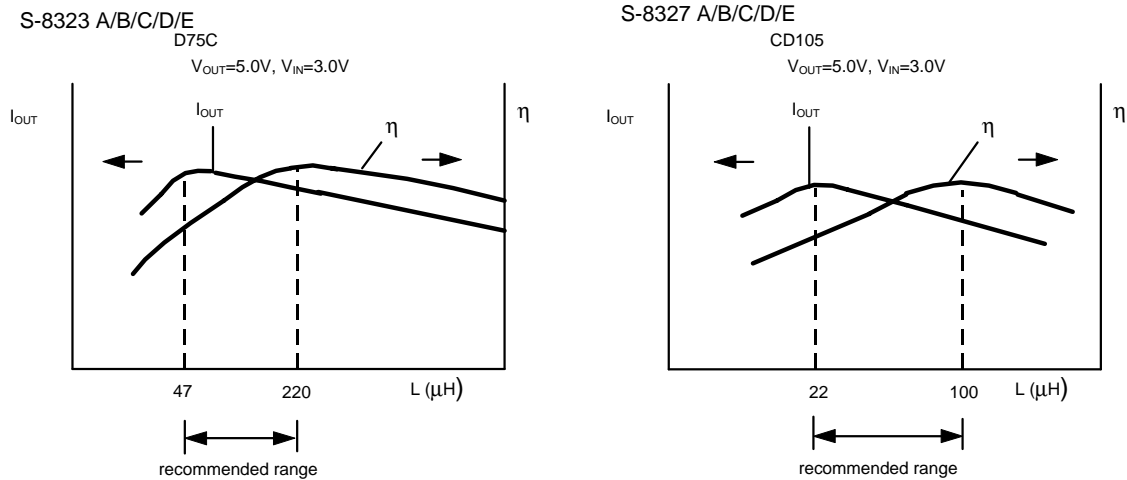

Figure 7

The peak current I_{PK} increases by decreasing L and I_{OUT} is at max. value at L value.

Further decreasing L decreases I_{OUT} due to the lack of the current driving capacity of the switching transistor.

The loss of I_{PK} by the switching transistor decreases by increasing L and the efficiency becomes max. at L value.

Further increasing L decreases efficiency due to the loss of DC resistance of the coil.

47 to 220 μ H inductor for S-8323 A/B/C/D/E, 22 to 100 μ H inductor for S-8327 A/B/C/D/E, 10 to 22 μ H inductor for S-8323 H/J, and 4.7 to 10 μ H inductor for S-8327 H/J are recommended.

Choose a value for L by referring to the reference data because the maximum output current is due to the input voltage in an actual case.

Choose an inductor so that the peak current I_{PK} does not exceed the allowable current.

Exceeding the allowable current of the inductor causes magnetic saturation, remarkable low efficiency and destruction of the IC chip due to a large current.

The peak current I_{PK} in uncontinuous mode is calculated from the following formula:

$$I_{PK} = \sqrt{\frac{2 I_{OUT} (V_{OUT} + V_D - V_{IN})}{f_{OSC} \cdot L}} \quad (A) \quad (17)$$

f_{OSC} : oscillation frequency

$V_D \cong 0.4V$

For instance, when you choose 100 μ H at $f_{OSC}=50$ kHz for L using the S-8323A50MC at the following conditions, I_{PK} is calculated to 170 mA from the (17) formula.

- Input voltage $V_{IN}=3$ V
- Output voltage $V_{OUT}=5$ V
- Load current $I_{OUT}=30$ mA

The switching current limit circuit is not built into this IC chip.

I_{PK} current must be 500 mA or less.

2. Diode

Use an external diode that meets the following requirements:

- Low forward voltage: $(V_F < 0.3V)$
- High switching speed: (50 ns max.)
- Reverse voltage: $V_{OUT} + V_F$ or more
- Rated current: I_{PK} or more

3. Capacitors (C_{IN} , C_{OUT})

A capacitor at the input side (C_{IN}) improves the efficiency by reducing the power impedance and stabilizing the input current. Select a C_{IN} value according to the impedance of the power supply used. The capacitor value should be around 10 μF .

A capacitor at the output side (C_{OUT}) is used for smoothing the ripple voltage. Therefore select a capacitor with a small ESR (Equivalent Series Resistance) and a large capacitance. The capacitor value should be 10 μF min. A tantalum electrolytic capacitor and an organic semiconductor capacitor are especially recommended because of their superior low-temperature characteristic and leakage current characteristic.

4. External transistor (S-8327 Series)

For the S-8327 Series, connecting an external transistor increases the output current. A bipolar (NPN) transistor or an enhancement (N-channel) MOS FET transistor can be used as external transistor.

4.1. Bipolar (NPN) transistor

A circuit example using a bipolar transistor (NPN), Sanyo 2SD1628G ($h_{FE} = 280$ to 560) is shown in Figure 11. The h_{FE} value and the R_b value determine the driving capacity to increase the output current using a bipolar transistor. A peripheral circuit example of the transistor is shown in Figure 8.

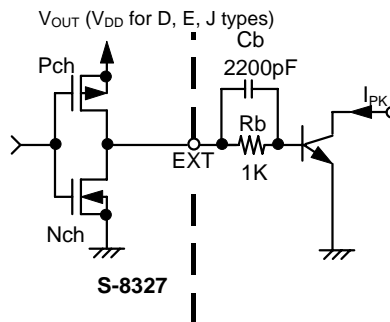

Figure 8 External transistor peripheral

1 k Ω is recommended for R_b . R_b is calculated from the following formula:

$$R_b = \frac{V_{OUT} - 0.7}{I_b} - \frac{0.4}{|I_{EXT}|} \quad (R_b = \frac{V_{DD} - 0.7}{I_b} - \frac{0.4}{|I_{EXT}|} \text{ for D, E, J types})$$

$$I_b : I_{PK} / h_{FE}$$

A small R_b increases output current, however, the efficiency decreases.

The current flows pulsating and there is voltage drop due to wiring resistance in an actual circuit, therefore optimum R_b value should be determined by experiment.

A speed-up capacitor connected in parallel with R_b resistance as shown in Figure 9 decreases the switching loss and improves the efficiency.

C_b is calculated from the following formula:

$$C_b \leq \frac{1}{2\pi \times R_b \times f_{OSC} \times 0.7}$$

However, in practice, the optimum C_b value also varies with the characteristics of the bipolar transistor to be employed. Therefore, determine the optimum value through experiments.

4.2. Enhancement MOS FET type

Figure 9 is a circuit example using NEC 2SK1959 MOS FET transistor (N-channel).

For a MOS FET, an N-channel power MOS FET should be used. Because the gate voltage and current of the external power MOS FET are supplied from the stepped up output voltage V_{OUT} , the MOS FET is driven more effectively.

Depending on which MOS FET you use in your device, there is a chance of a current overrun at power ON.

Thoroughly test all settings with your device before deciding on which one to use. Also, try to use a MOS FET with the gate capacitance of 300 pF or less.

Since the ON resistor of the MOS FET might affect the output amperage as well as the efficiency, the threshold voltage should be low. When the output voltage is as low as 2.0V the same as in the S-8327E20, the circuit operates only when the MOS FET has the threshold voltage lower than 2.0V.

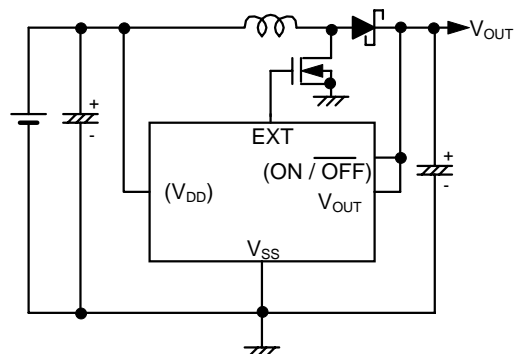

Figure 9 Circuit example using 2SK1959

5. Others (S-8323D/J and S-8327E/J only)

The S-8323D/J and S-8327E/J are applicable to the following uses because the power pin for IC chip and V_{out} pin for output voltage are separated:

- ① When changing the output voltage with an external resistance.
- ② When outputting the high voltage such as +12 V or +15 V.
- ③ When making the step-down DC/DC converter
- ④ When making the voltage inverting type DC/DC converter.

Choose the products in the following table according to applications for ① to ③.

Use	Step-up					Step-down				
	Output voltage V_{CC}	$2V \leq V_{CC} < 3V$	$3V \leq V_{CC} < 5V$	$5V \leq V_{CC} < 9V$	$9V \leq V_{CC}$	Ref. circuit	$2V \leq V_{CC} < 3V$	$3V \leq V_{CC} < 5V$	$5V \leq V_{CC} < 9V$	Ref. circuit
S-8323D20	○	—	—	—	—	Std. circuit (5)	○	—	—	Appl. circuit 3
S-8323D30	—	○	—	—	—	Std. circuit (5)	—	○	—	Appl. circuit 3
S-8323D50	—	—	○	—	—	Std. circuit (5)	—	—	○	Appl. circuit 3
S-8323J25	—	○	—	—	—	Std. circuit (5)	—	—	—	—
S-8323J50	—	—	○	—	—	Std. circuit (5)	—	—	—	—
S-8327E20	○	○	○	○	○	Std. circuit (6)	—	—	—	—
S-8327E50	—	—	○	○	○	Std. circuit (6)	—	—	—	—
S-8327J25	—	○	○	○	○	Std. circuit (6)	—	—	—	—
S-8327J50	—	—	○	○	○	Std. circuit (6)	—	—	—	—
Connection to V_{DD} pin	V_{IN} or V_{CC}	V_{IN} or V_{CC}	V_{IN} or V_{CC}	V_{IN}	V_{IN}	—	V_{IN}	V_{IN}	V_{IN}	—

The operational precautions are follows:

- I. This IC starts to oscillate and step up operation at $V_{DD}=0.8V$ (1.3V for J-type) but frequency of the oscillator does not stabilize.
 Input the voltage from 2 V to 9 V for V_{DD} pin to get the stabilized output voltage and oscillation frequency.
 The input voltage from 2 V to 9 V for V_{DD} pin allows the connection of V_{DD} pin to both input power pin V_{IN} and output power pin V_{out} .
- II. Choose external resistors R_A and R_B not to affect to the output voltage with the consideration of the impedance between V_{OUT} and V_{SS} pins in the IC chip.
 Internal resistance between V_{OUT} and V_{SS} pins are as follows:
 - ① S-8323D20, S-8323J20 and S-8327E20: 3.0 MΩ to 19.6 MΩ
 - ② S-8323J25, S-8327J25: 3.9 MΩ to 22.5MΩ
 - ③ S-8323D30: 3.3 MΩ to 22.6 MΩ
 - ④ S-8323D50, S-8323J50, S-8327E50 and S-8327J50: 2.1 MΩ to 19.1 MΩ
- III. Attach the capacitor “ C_C ” in parallel to R_A resistance when the oscillation of the output voltage occurs.
 Calculate “ C_C ” from the following formula:

$$C_C (F) = \frac{1}{2 \cdot \pi \cdot R_A \cdot 20 \text{ kHz}}$$

IV. When the device is used with an external resistance in the output voltages-variable mode, a large ripple voltage having a frequency lower than that of the switching frequency may appear as an output, if the load current is large, depending on the circuit patterns on the evaluation board and other factors (the interval is several times or a few tens times as large as the switching interval (4μS), see waves in Figure 10). Be sure to check the circuit patterns on your board in advance for practical use.

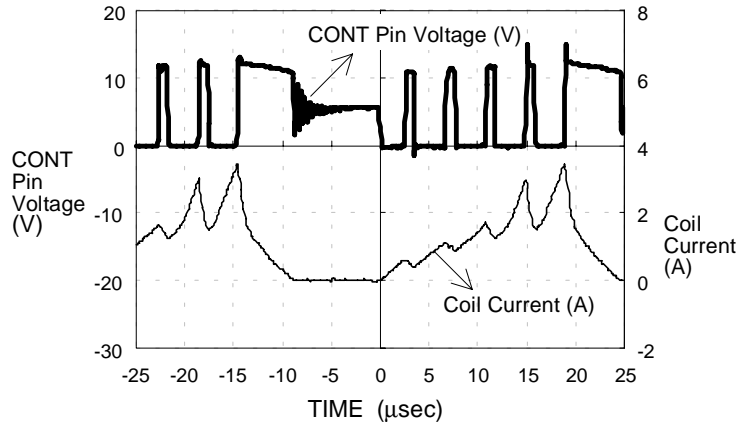
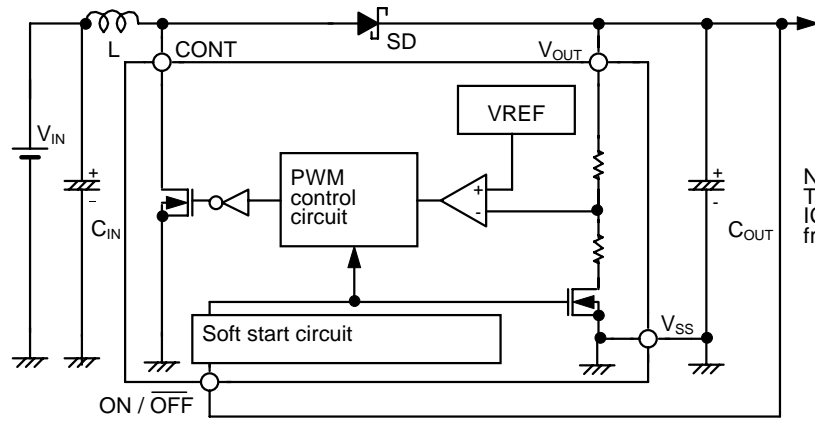

Figure 10

■ **Standard Circuits**

(1) S-8323AXXMC



Note:
The power supply for IC chip is supplied from V_{OUT} pin.

Figure 11

(2) S-8327BXXMC
S-8327HXXMC

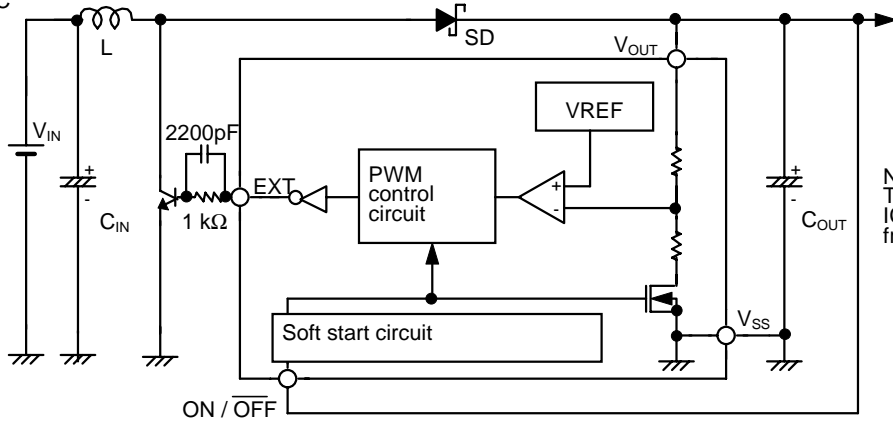

Note:
The power supply for IC chip is supplied from V_{OUT} pin.

Figure 12

(3) S-8323AXXMA
S-8323AXXUA
S-8323CXXMA

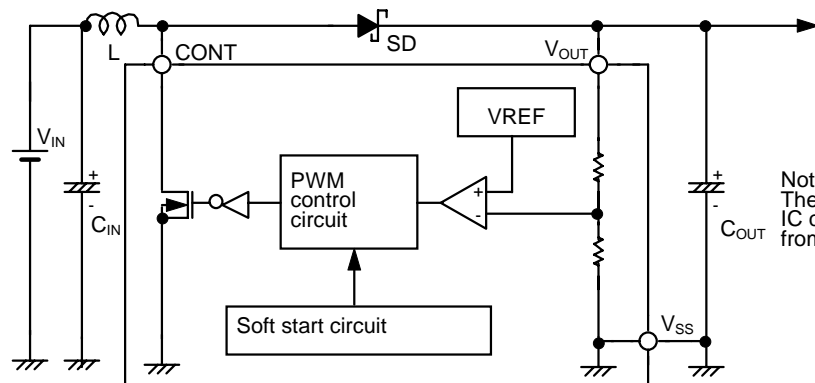

Note:
The power supply for IC chip is supplied from V_{OUT} pin.

Figure 13

- (4) S-8327BXXMA
S-8327BXXUA

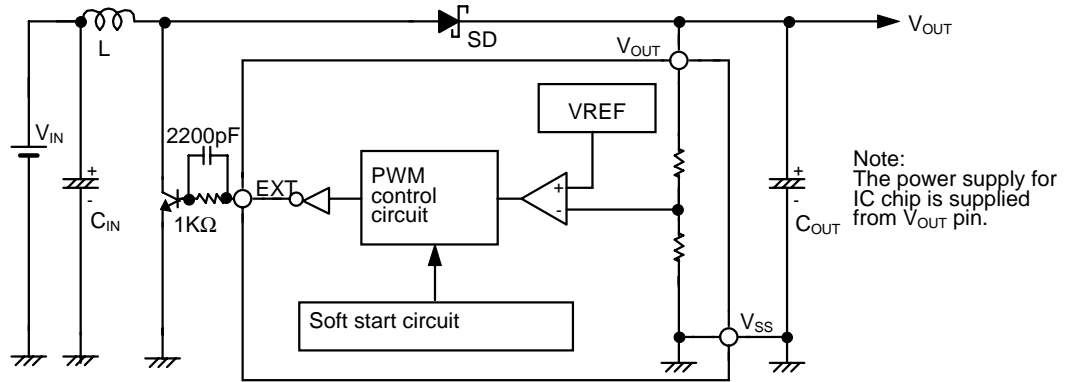

Figure 14

- (5) S-8323DXXMC (Output voltage adjustment circuit with external resistors)
S-8323JXXMC

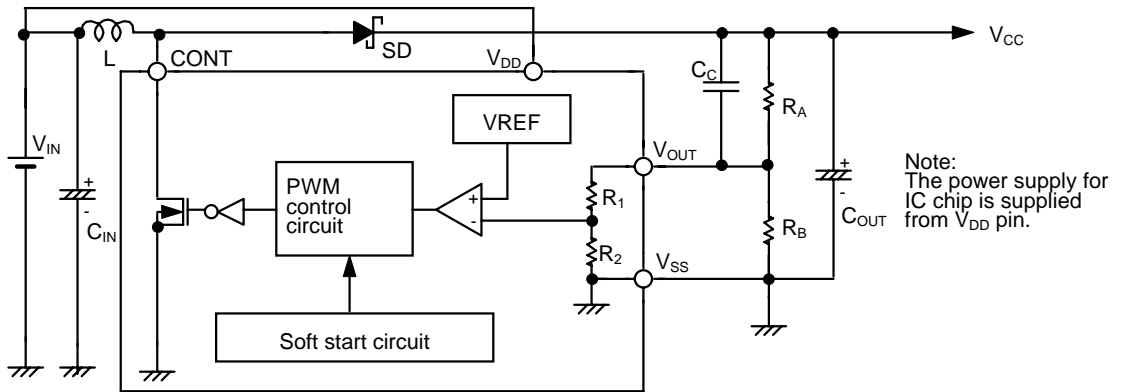

Figure 15

- (6) S-8327EXXMC (Output voltage adjustment circuit with external resistors)

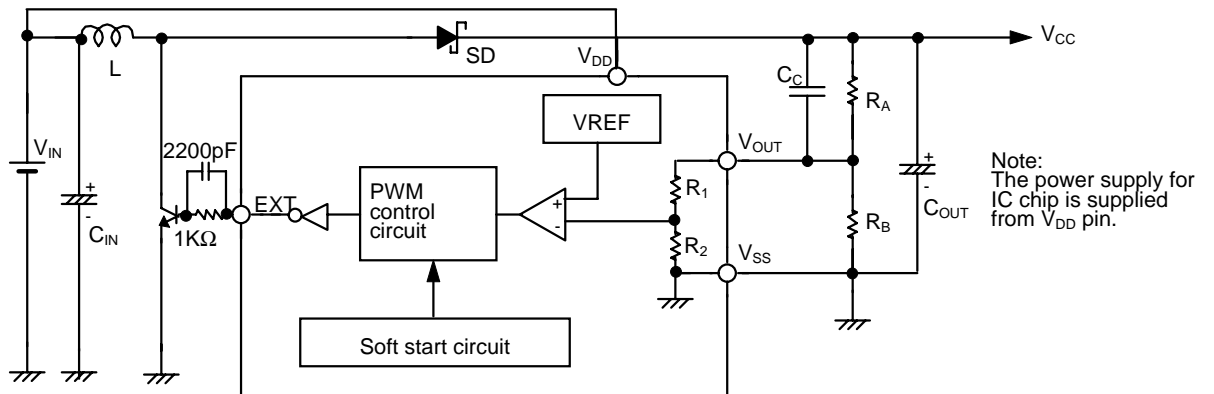

Figure 16

(7) S-8327JXXMC

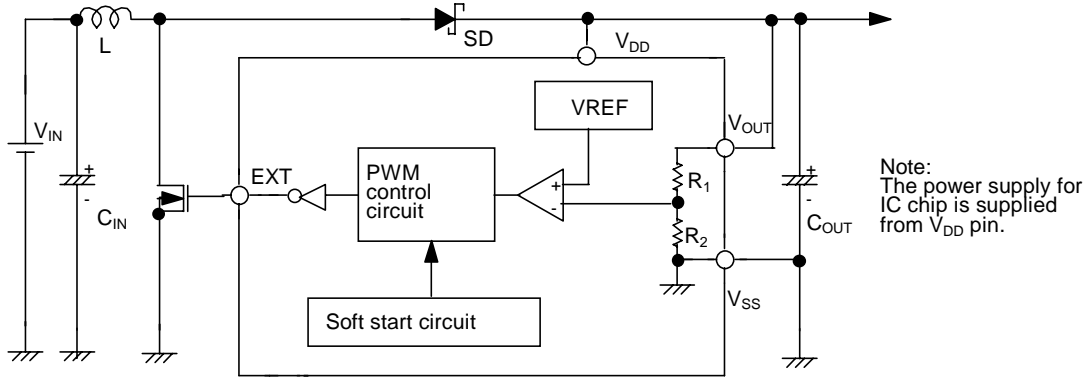

Figure 17

(8) S-8327HXXMC

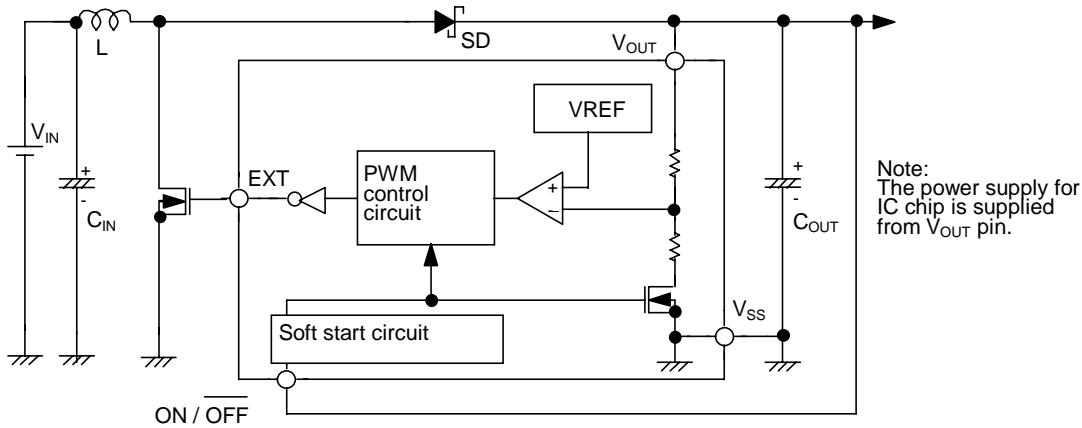

Figure 18

■ Precautions

- Mount external capacitors, a diode, and a coil as near as possible to the IC.
- Ripple voltage and spike noise occur in switching regulators. Because they largely depend on the coil and the capacitor used, check them using an actually mounted model.
- The performance of this IC varies depending on the PCB patterns, peripheral circuits or external parts. Thoroughly test all settings with your device. Also, try to use recommended external parts. If not, contact your local SII Sales Office.
- Seiko Instruments shall not be responsible for any patent infringement by products including S-8323/8327 Series in connection with the method of using S-8323/8327 Series in such products, the specification of such products, or the country of destination thereof.
- Make sure dissipation of the switching transistor (especially at a high temperatures) does not exceed the allowable power dissipation of the package.

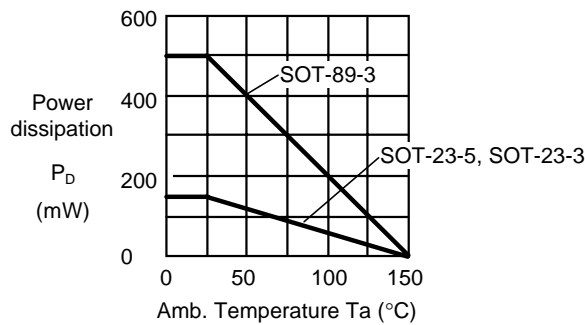

Figure 19 Power dissipation of the package (before mounting)

■ Application Circuits

1. Backup Circuit

Reduces the backup battery voltage from 3 V to 1.5 V (from 2 cells to 1 cell).

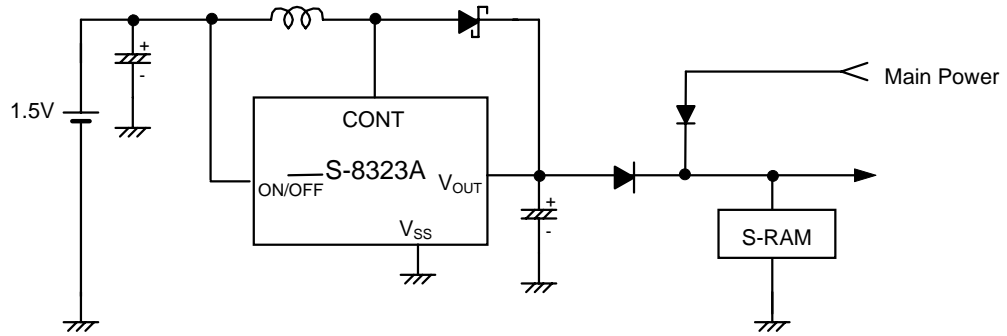

Figure 20

2. 5V/Backup Change

For the products with shutdown function built-in, V_{OUT} becomes about $V_{IN}-0.6V$ at shutdown. This characteristic allows the backup voltage of the microcomputer to be supplied with low current consumption.

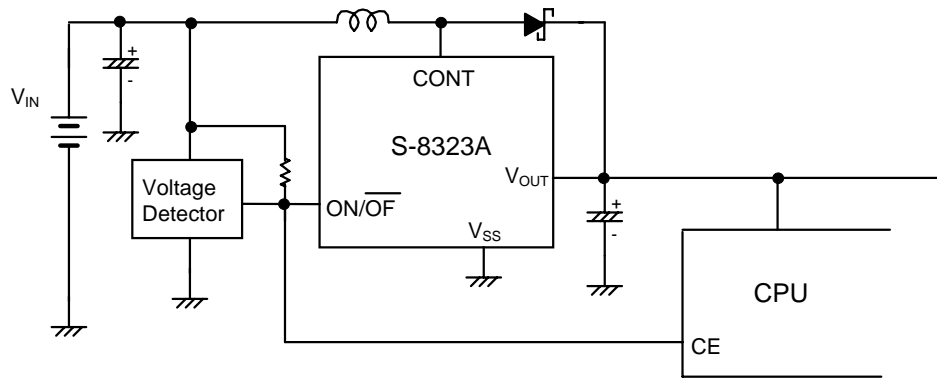

Figure 21

3. Step-down DC/DC converter

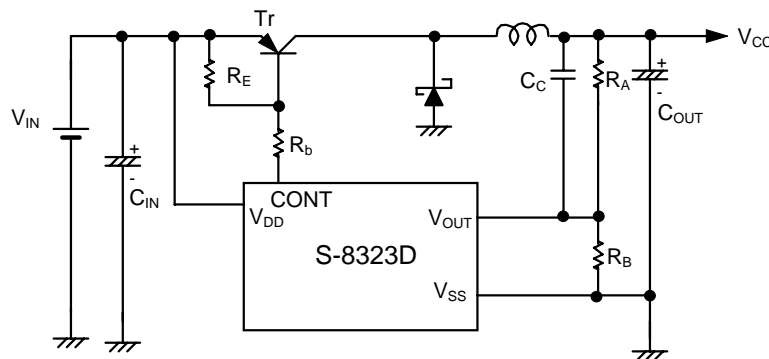

Figure 22

The start circuit is not needed because the power supply is supplied from V_{DD} to the IC.

The maximum input voltage for V_{DD} is 9 V.

DO NOT mount R_A and R_B resistors when V_{CC} is 2V for S-8323D20MC, 3V for S-8323D30MC and 5V for S-8323D50MC.

The external resistor R_b must be 60Ω or more and R_E must be $6k\Omega$ or less. A large value for R_E raises efficiency due to the reduction of reactive current for R_E and R_b .

Too large value of R_E lowers efficiency due to the large switching loss of the external transistor (Tr). Choose a suitable value of R_E under the operating conditions.

4. PDA/Digital Camera Power Supply

The following are a circuit example and its characteristics showing a 3-V system drive (3V/200mA) powered by 4 secondary Nicd batteries (3.6 to 4.8V), 2 lithium-ion batteries (4.8 to 8.8V) or 4 alkaline-manganese batteries (3.6 to 6.0V).

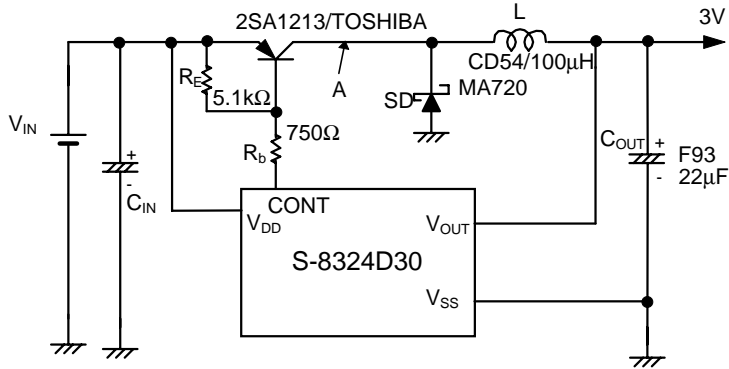

Figure 23

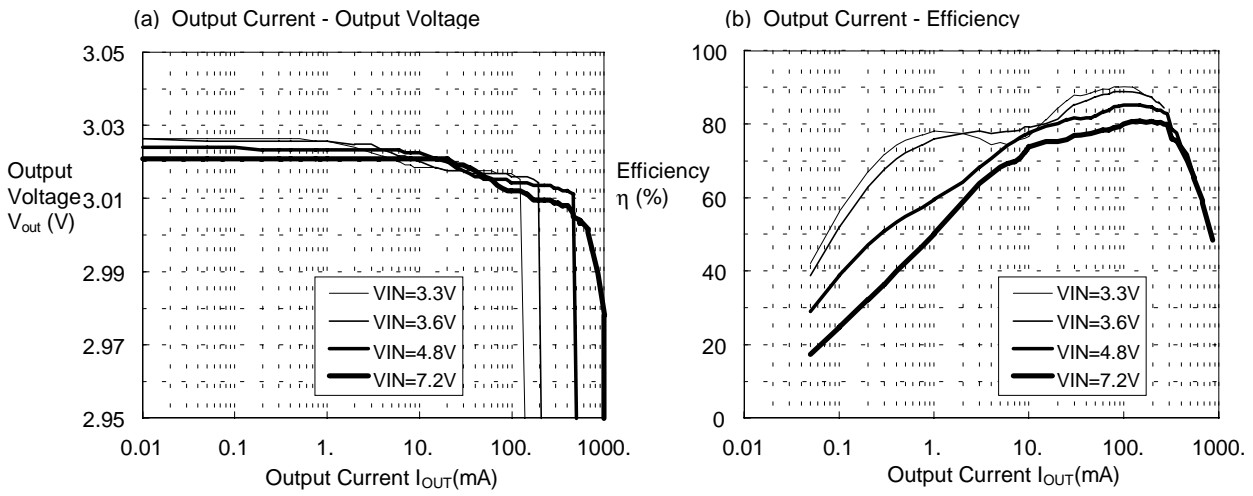

Figure 24

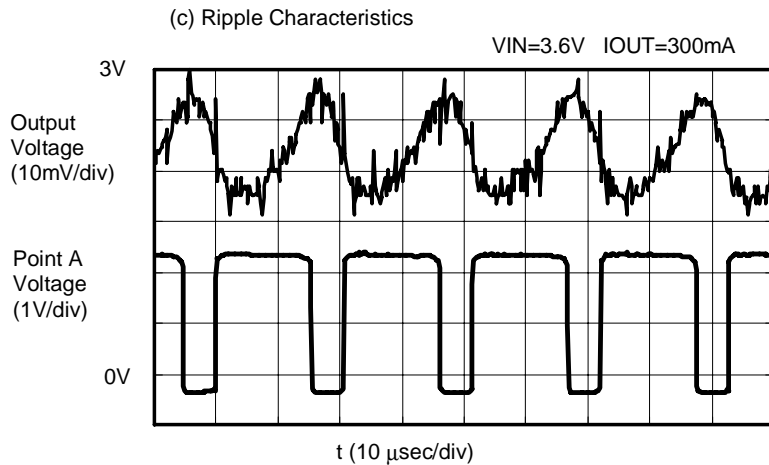

Figure 25

5. Voltage Inverting Type DC/DC Converter

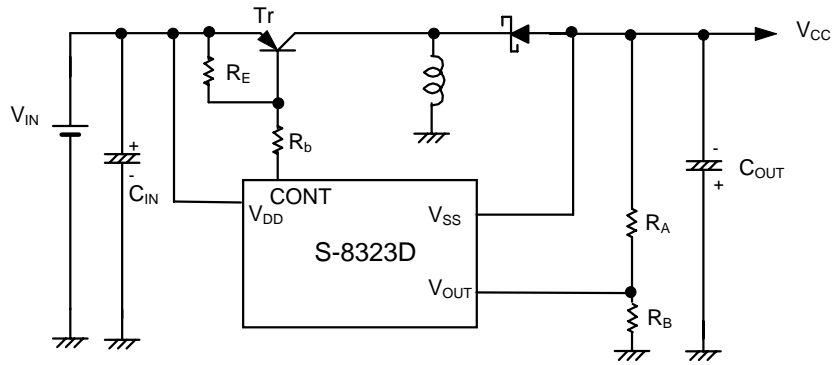

Figure 26

The Start circuit is not needed because the power is supplied from V_{DD} to the IC. Set V_{IN} to $9V-|V_{CC}|$ or less.

When V_{CC} is -2 V, -3 V and -5 V, use the S-8323D20MC, the S-8323D30MC and the S-8323D50MC respectively. Always connect V_{OUT} to GND without attaching R_A , R_B .

Set R_b to 60Ω or more and R_E to $6\text{ k}\Omega$ or less. The larger R_E , the smaller the reactive current through R_E and R_b , allowing the efficiency to be improved. On the other hand, the switching loss of the Tr becomes large and consequently the efficiency will be worsend. Select R_E to ensure high efficiency under operating conditions.

6. Power Supply for GaAs and MR Head

The following are an application negative power supply circuit for GaAs and MR head, and its characteristics when -3V ($-3V\pm 10\%$) and -5V ($-5V\pm 10\%$) are used for the applied power. Set V_{IN} to $9V-|V_{CC}|$ or less.

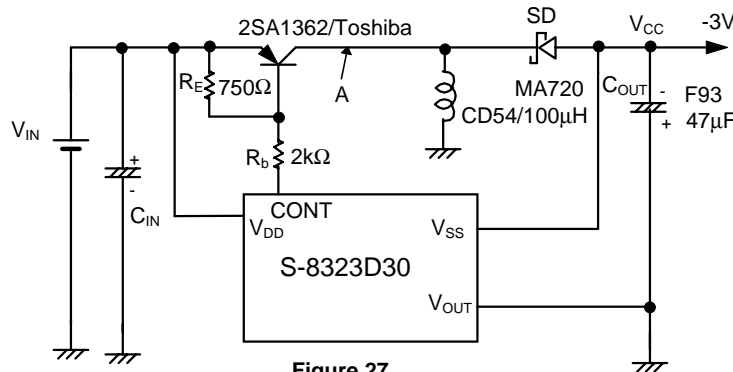

Figure 27

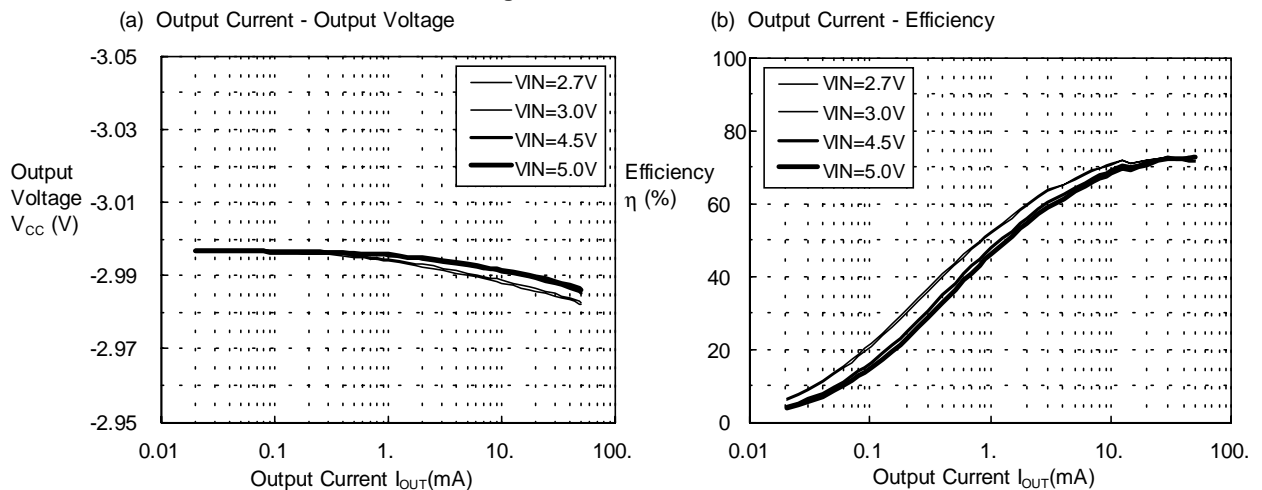

Figure 28

(c) Ripple Characteristics

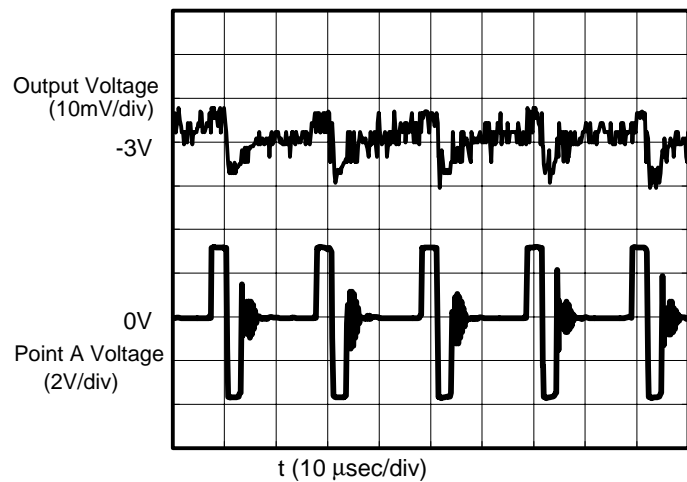

Figure 29

When output current I_{OUT} exceeds 50 mA, the current capacitance in the external transistor 2SA1362 becomes in short supply and the IC may be broken. Select a large current capacitance transistor.

The start circuit is not needed because the power supply is supplied from V_{DD} to the IC. Set V_{in} to $9V - |V_{CC}|$ or less.

The output voltage cannot be changed with external resistors.

Set R_b to 60Ω or more and R_E to $6k\Omega$ or less. The larger R_E , the smaller the reactive current through R_E and R_b , allowing the efficiency to be improved. On the other hand, the switching loss of the Tr becomes large and consequently the efficiency will be worsened. Select R_E to ensure high efficiency under operating conditions.

7. LCD Power Supply (Standard circuit (6))

The following are an application power supply circuit (30V/5mA) for intermediate and large size LCD, and its characteristics when 3V ($3V \pm 10\%$) and 5V ($5V \pm 10\%$) are used for the applied power.

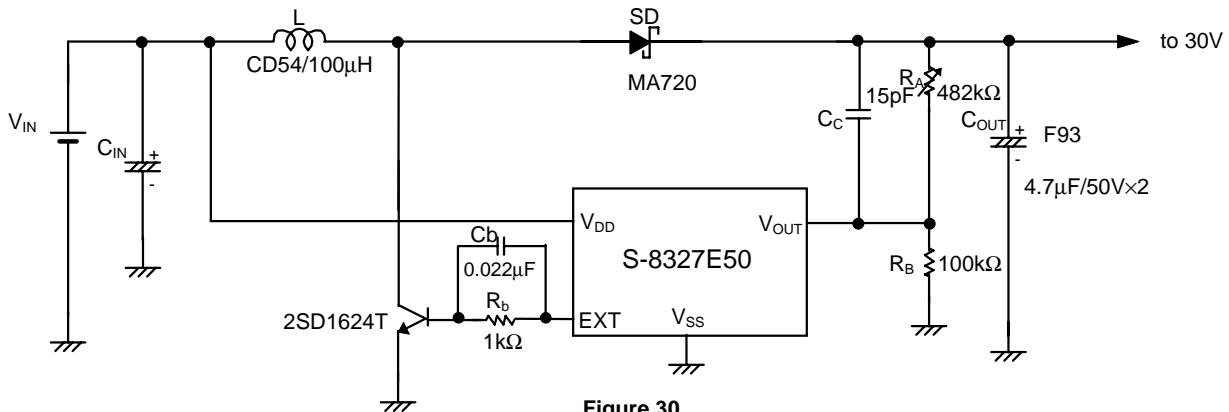

Figure 30

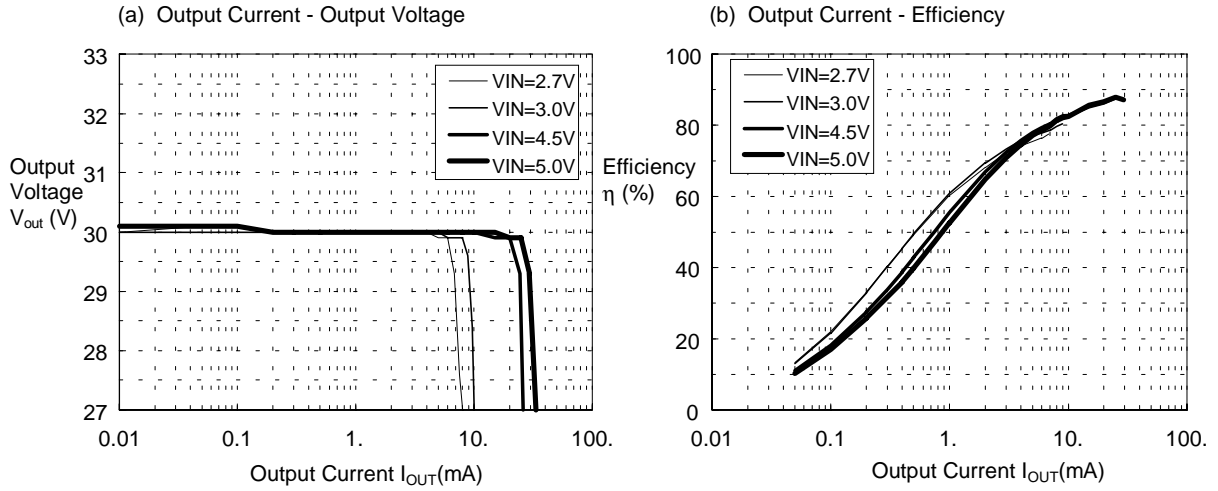

Figure 31

8. Flash Memory Power Supply

The following are a circuit example and its characteristics for a 5 V Flash Memory, 16 Mbit (5V/120mA) on a single lithium battery (2.4 V to 4.4 V).

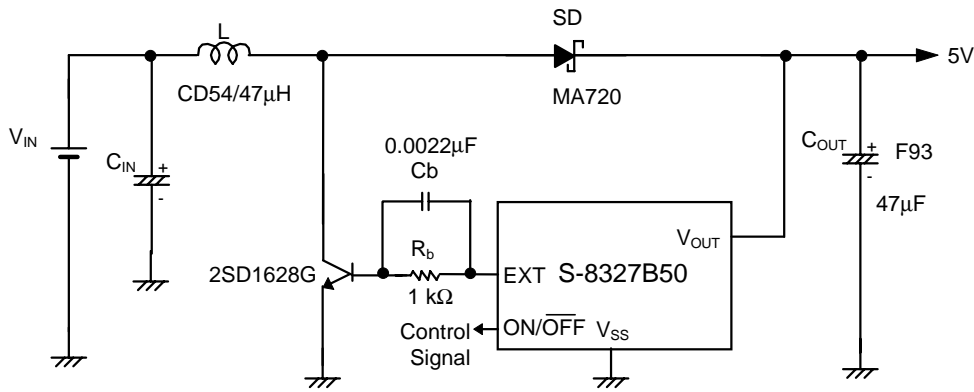

Figure 32

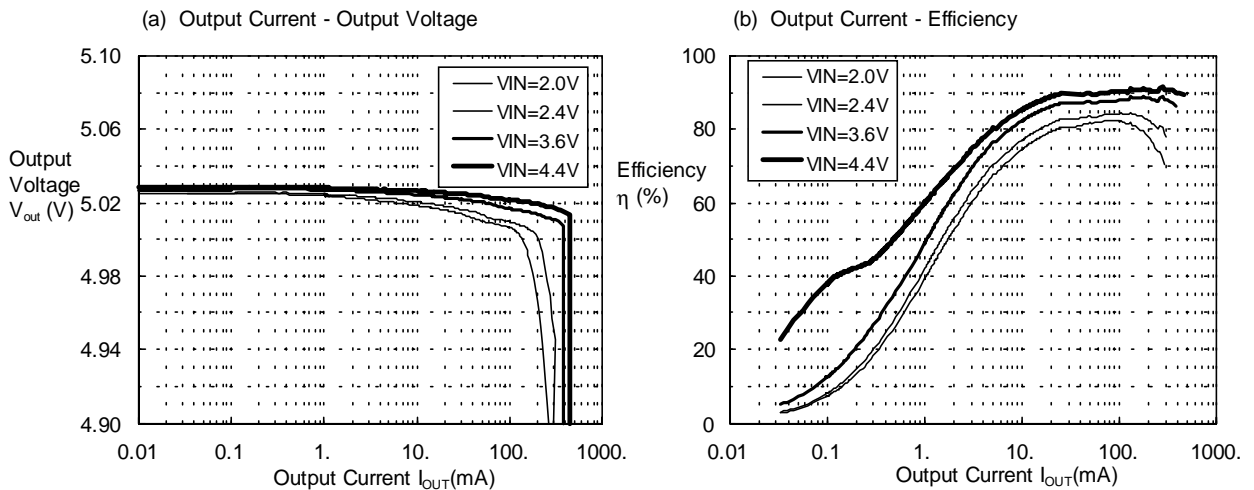

Figure 33

9. Power Supply for CCD

The follows are a circuit example and its characteristics for CCD power supply (+15, -5.5V/10mA) powered by 4 alkaline-manganese batteries (3.6-6.0V), used for digital still cameras and others.

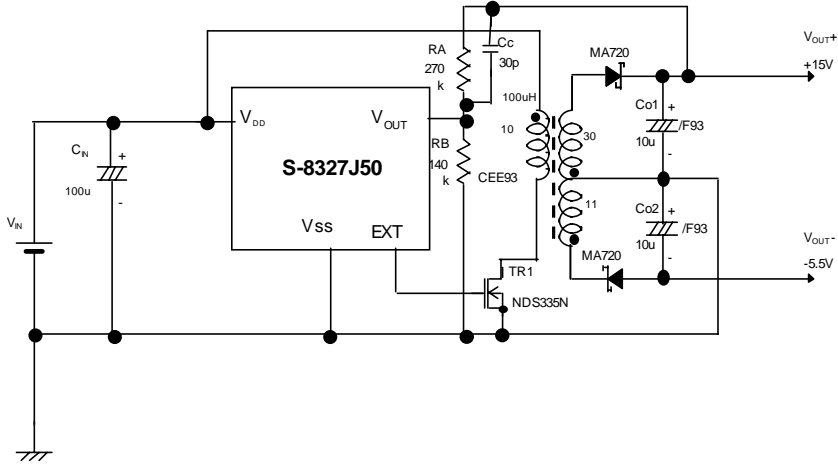

Figure 34

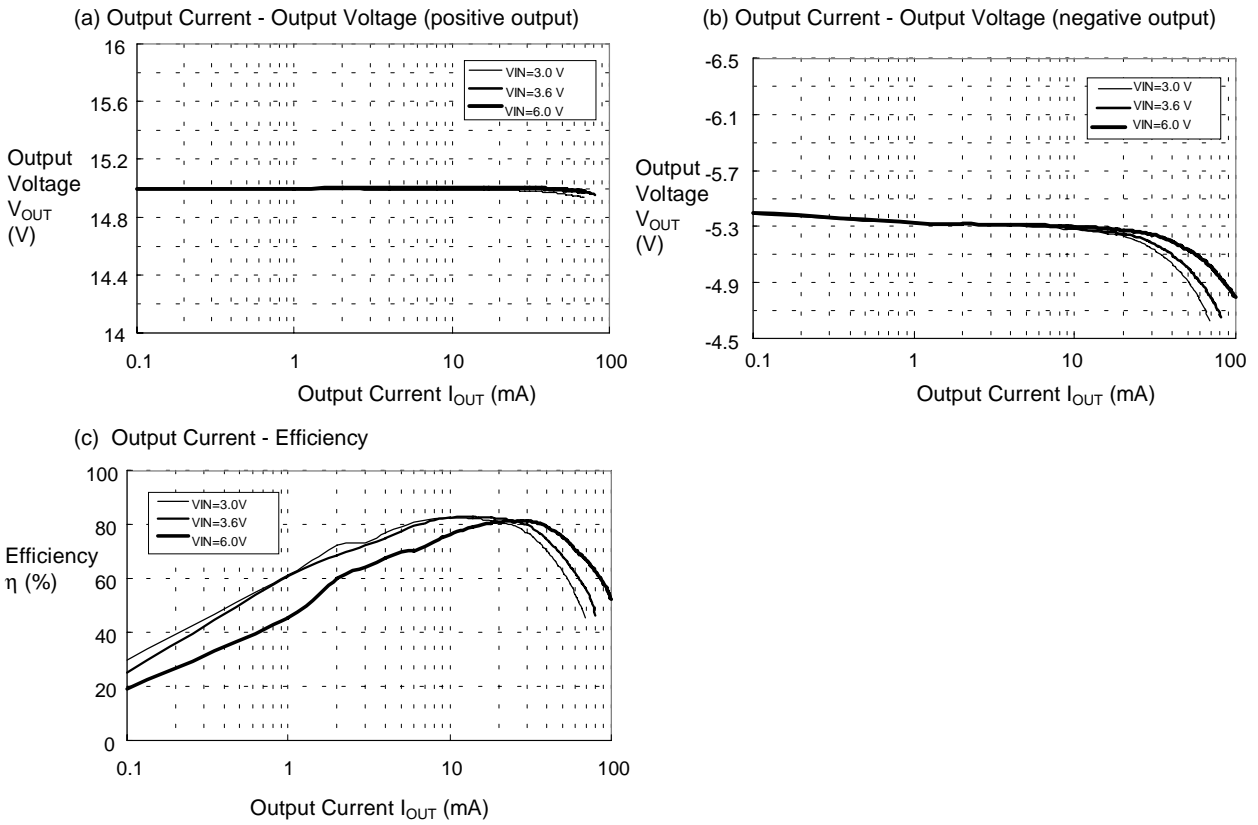
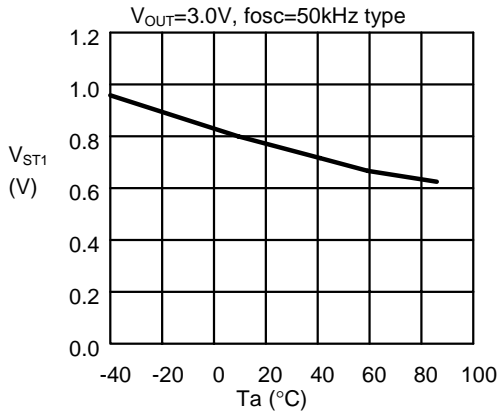

Figure 35

■ Temperature Characteristics

V_{ST1} - T_a
S-8323



V_{ST2} - T_a
S-8323

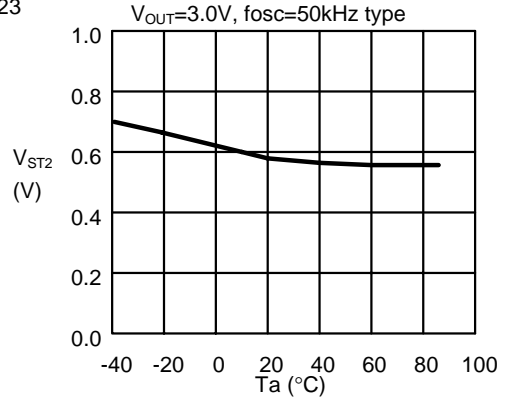

I_{SS1} - T_a
S-8323

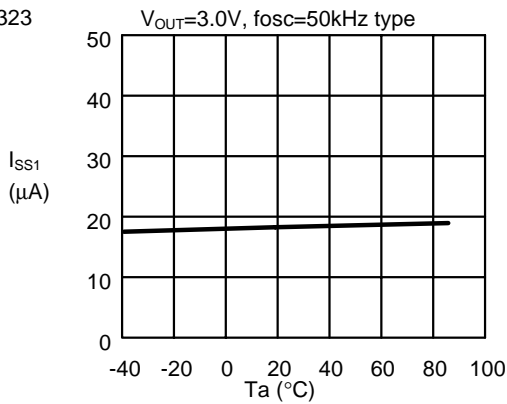

I_{SS2} - T_a
S-8323

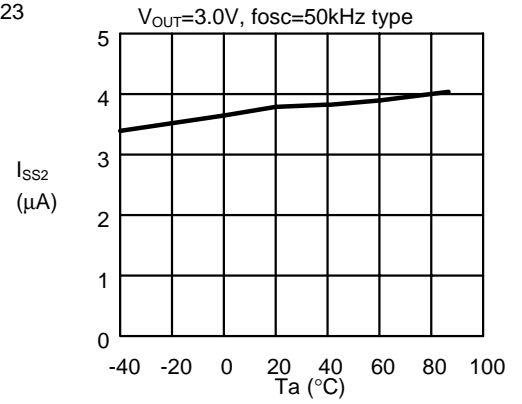

I_{SS3} - T_a
S-8323

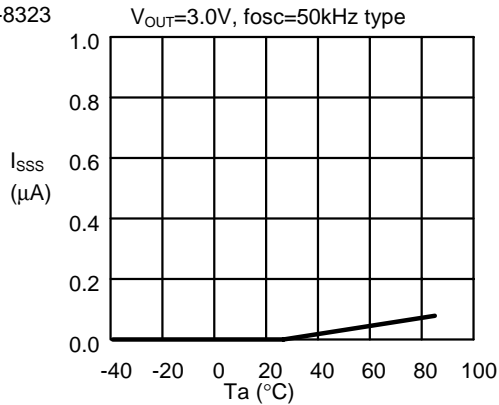

I_{SW} - T_a
S-8323

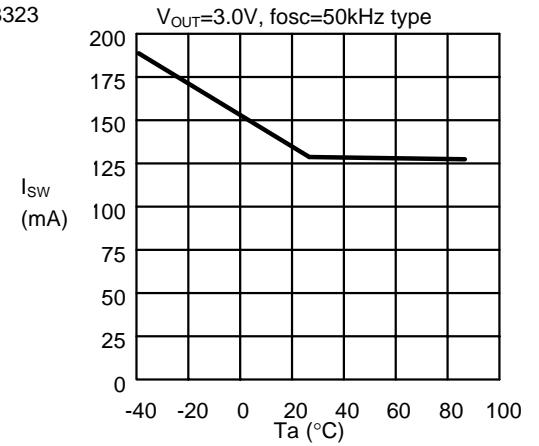

I_{SWQ} - T_a
S-8323

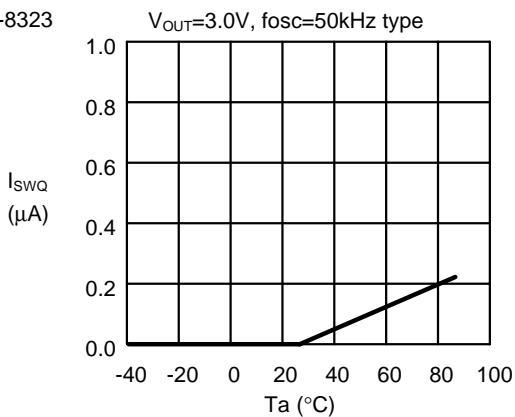

f_{osc} - T_a
S-8323

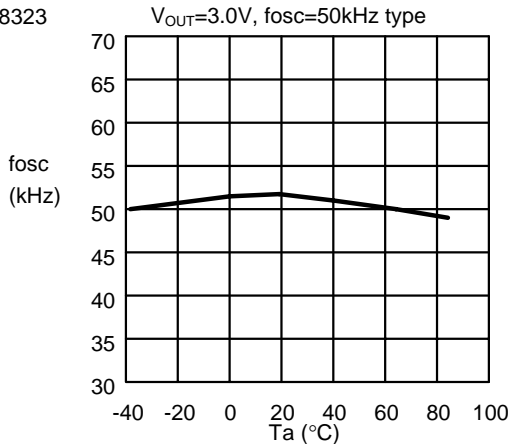

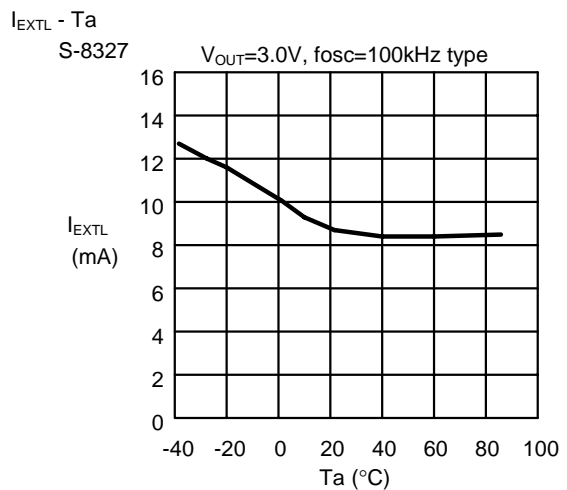
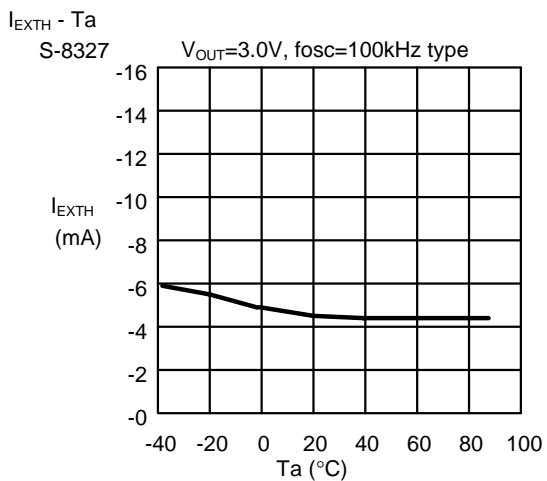
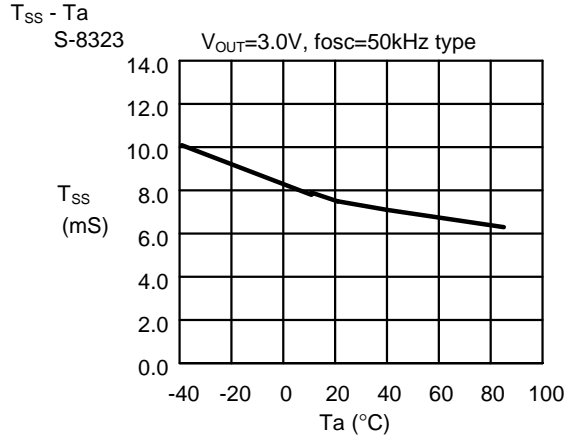
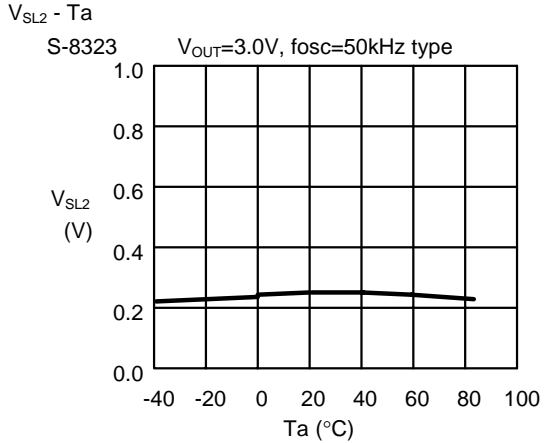
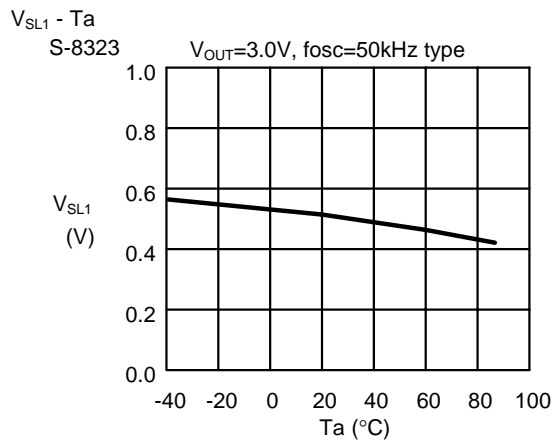
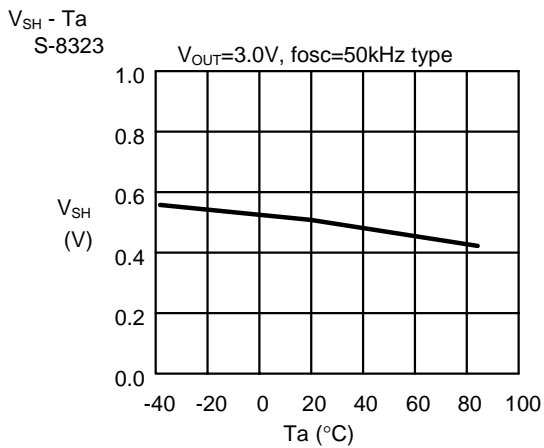
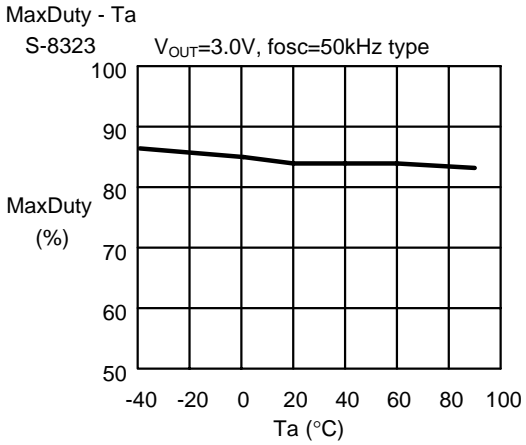

$V_{ST1} - T_a$
S-8323 $V_{OUT}=3.3V, f_{osc}=250kHz$ type

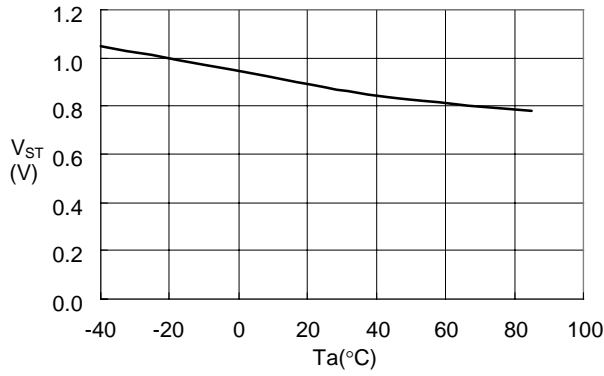

$V_{ST2} - T_a$
S-8323 $V_{OUT}=3.3V, f_{osc}=250kHz$ type

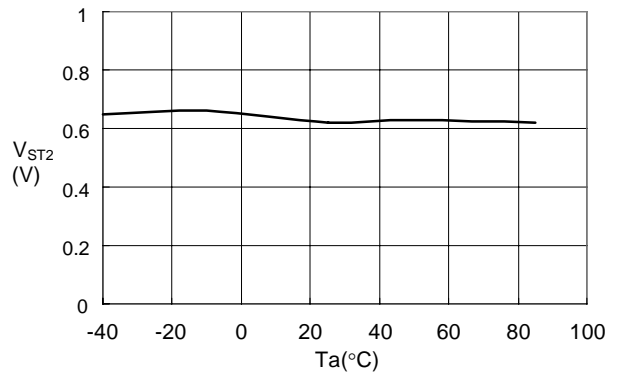

$I_{SS1} - T_a$
S-8323 $V_{OUT}=3.3V, f_{osc}=250kHz$ type

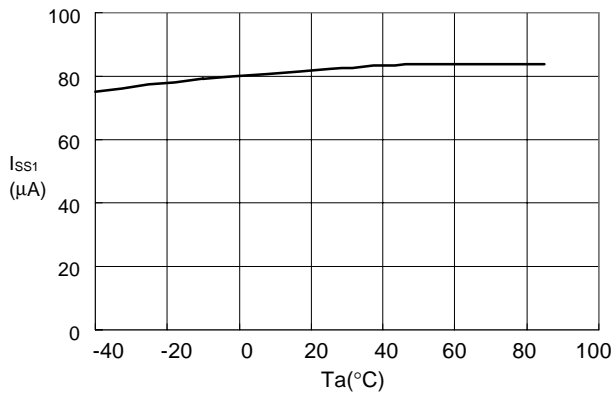

$I_{SS2} - T_a$
S-8323 $V_{OUT}=3.3V, f_{osc}=250kHz$ type

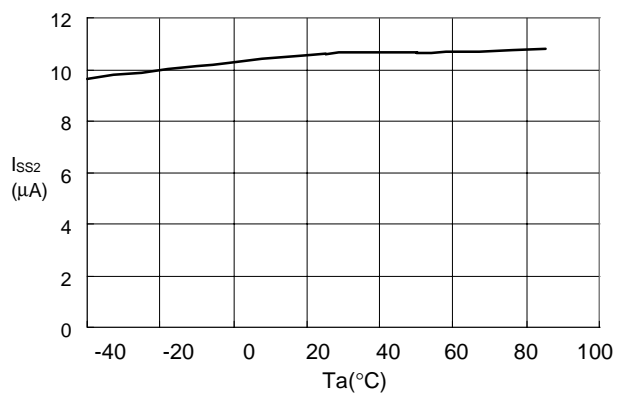

$f_{osc} - T_a$
S-8323 $V_{OUT}=3.3V, f_{osc}=250kHz$ type

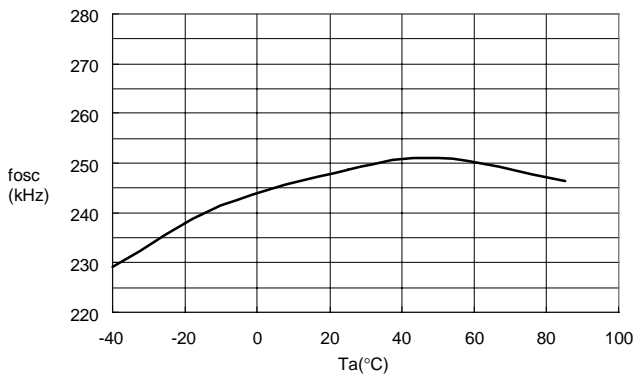

MaxDuty - Ta
S-8323 $V_{OUT}=3.3V, f_{osc}=250kHz$ type

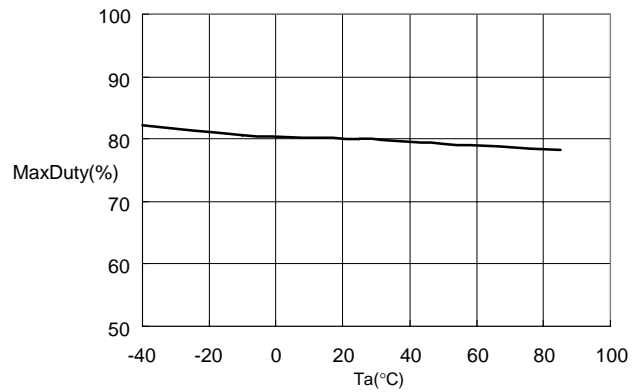

■ **Voltage Characteristics**

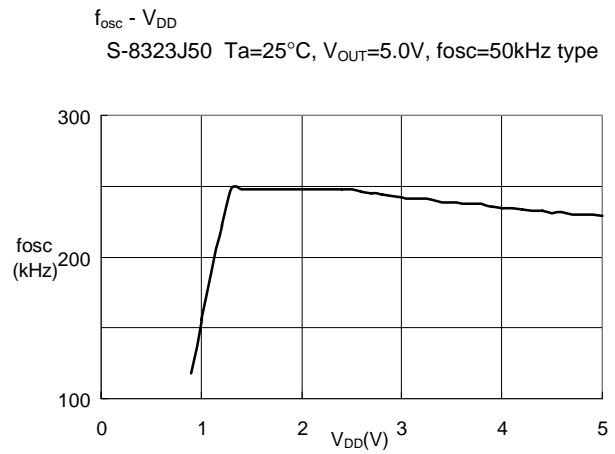
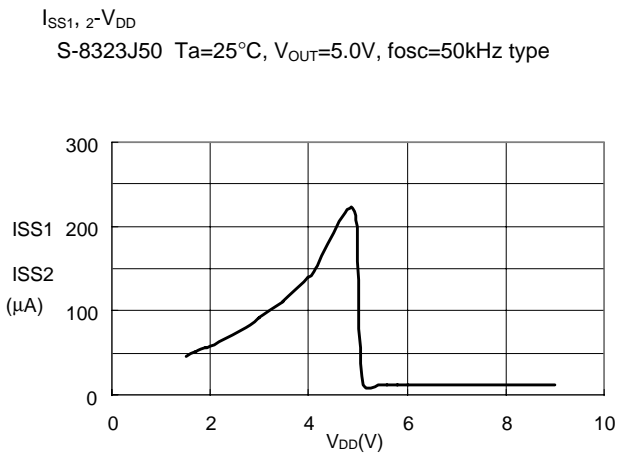
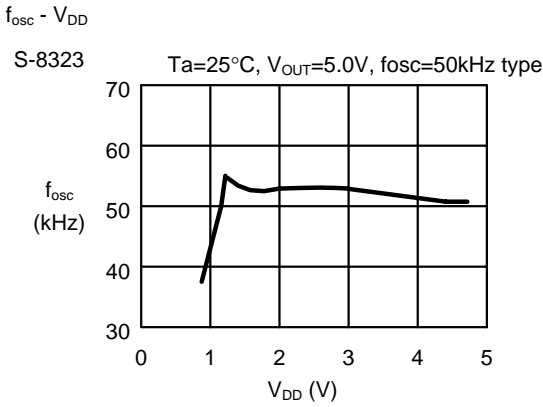
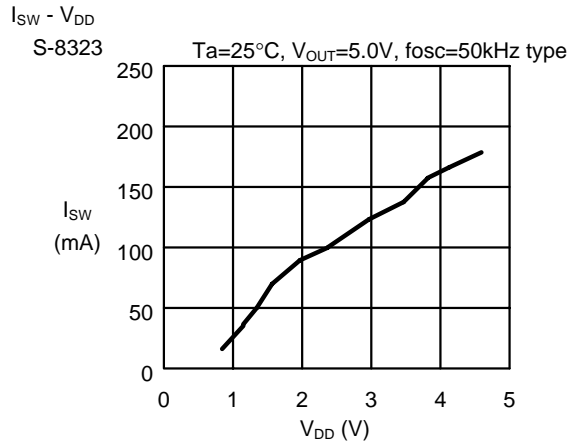
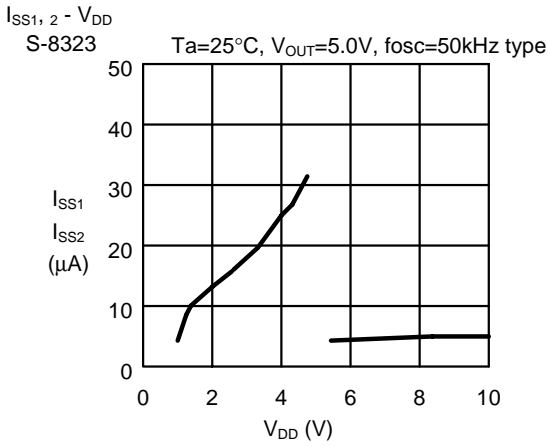

■ Ripple Characteristics

S-8323A30

1. Light Load ($I_{OUT}=200\mu A$)

$V_{IN}=1.8V$

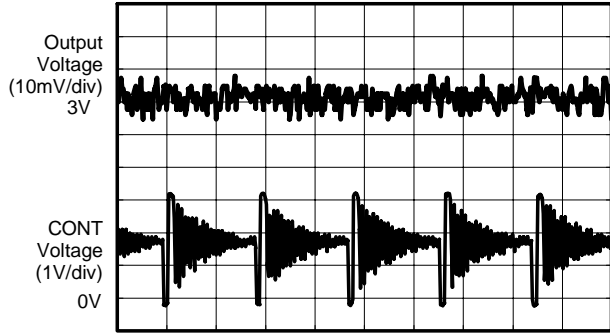

t (10 μsec/div)

2. Medium Load ($I_{OUT}=10mA$)

$V_{IN}=1.8V$

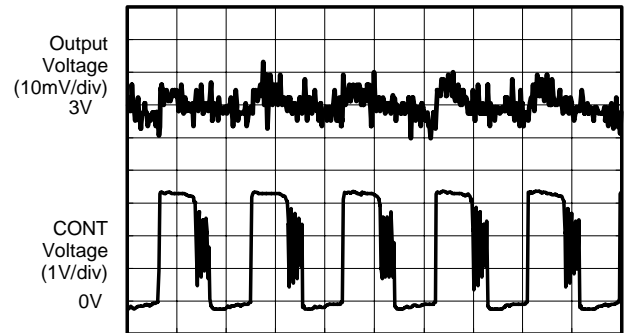

t (10 μsec/div)

3. Heavy Load ($I_{OUT}=60mA$)

$V_{IN}=1.8V$

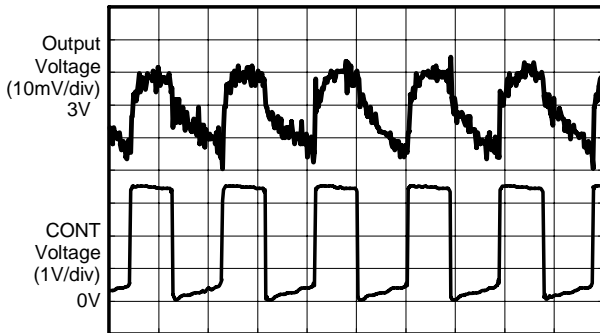

t (10 μsec/div)

S-8327B30

1. Light Load ($I_{OUT}=200\mu A$)

$V_{IN}=1.8V$

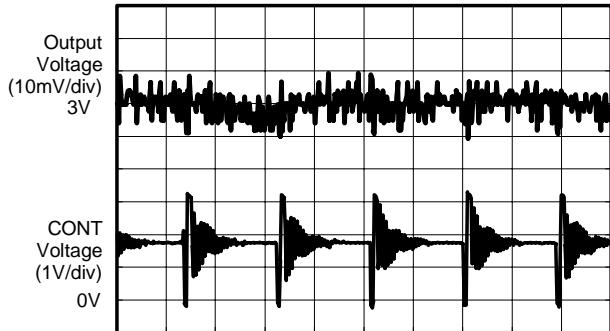

t (5 μsec/div)

2. Medium Load ($I_{OUT}=10mA$)

$V_{IN}=1.8V$

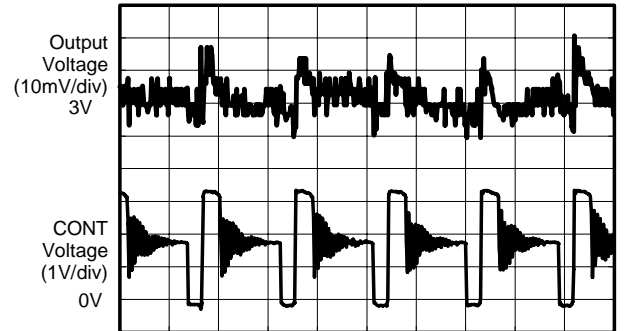

t (5 μsec/div)

3. Heavy Load ($I_{OUT}=200mA$)

$V_{IN}=1.8V$

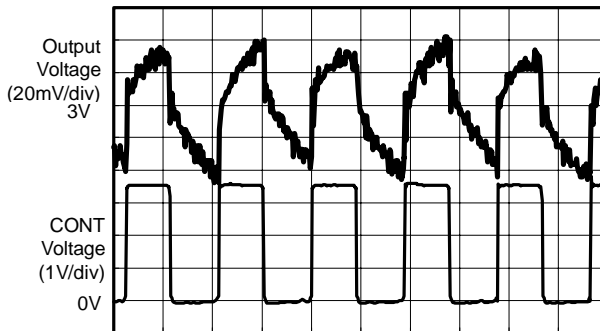

t (5 μsec/div)

■ **Transient Responses**

1. Powering ON due to V_{IN} (V_{IN} : 0V → 1.8V)

S-8323A30 (Light Load: $I_{OUT}=1mA$)

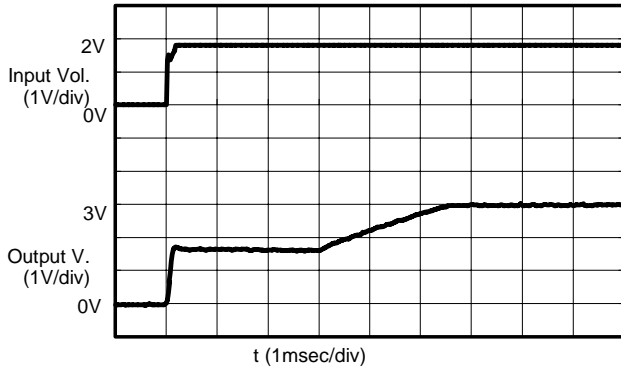

S-8323A30 (Heavy Load: $I_{OUT}=60mA$)

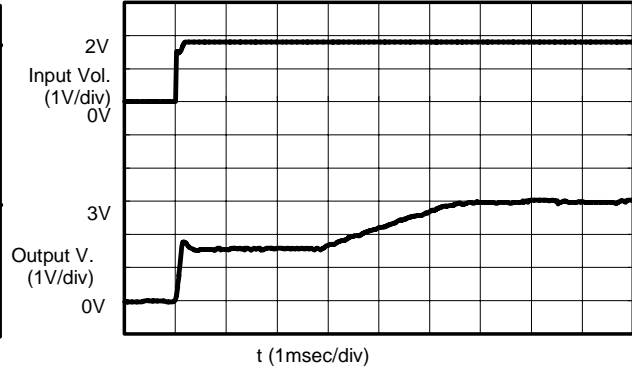

S-8327B30 (Light Load: $I_{OUT}=1mA$)

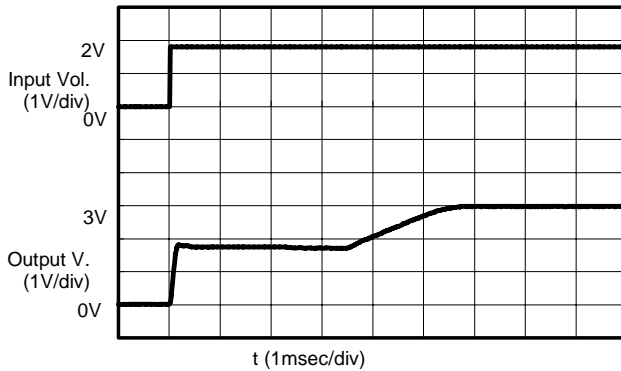

S-8327B30 (Heavy Load: $I_{OUT}=200mA$)

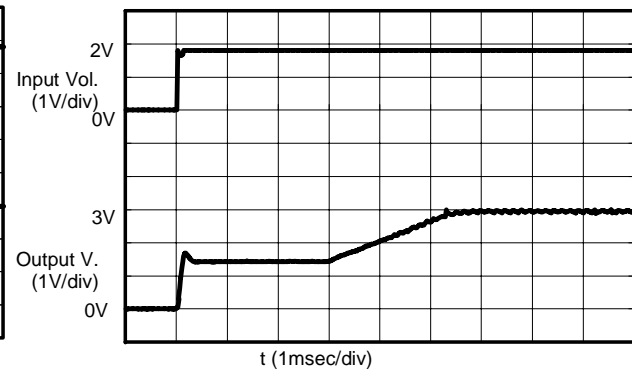

2. Powering ON due to Shutdown pin ($V_{on/off}$: 0V → 3.0V)

S-8323A30 (Light Load: $I_{OUT}=1mA$)

$V_{IN}=1.8V$

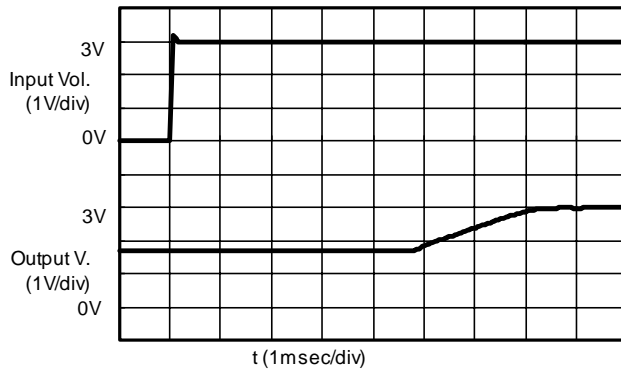

S-8323A30 (Heavy Load: $I_{OUT}=60mA$)

$V_{IN}=1.8V$

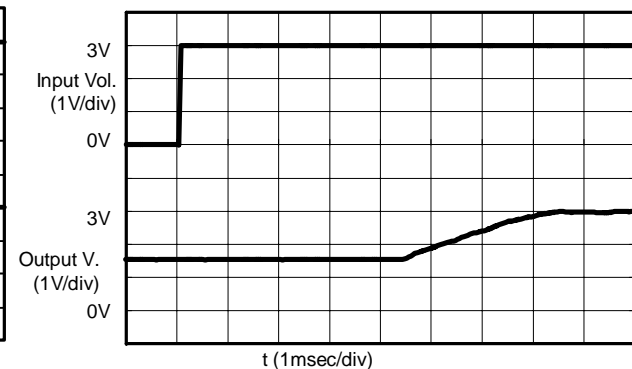

S-8327B30 (Light Load: $I_{OUT}=1mA$)

$V_{IN}=1.8V$

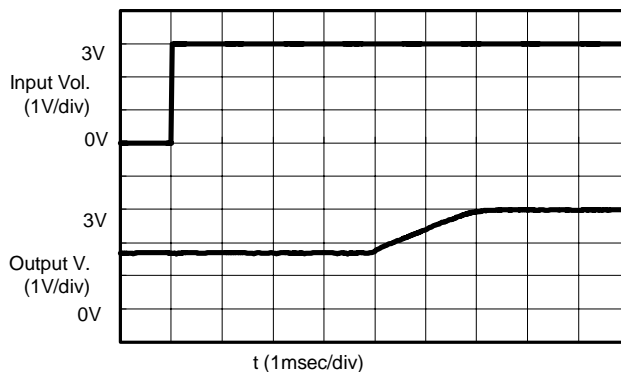

S-8327B30 (Heavy Load: $I_{OUT}=200mA$)

$V_{IN}=1.8V$

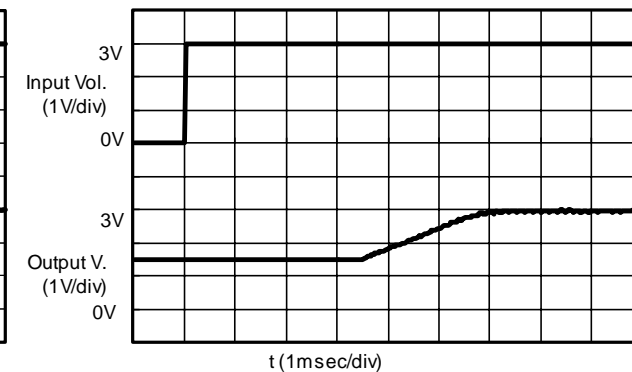

3. Load Fluctuations

S-8323A30 ($I_{OUT}:100\mu A \rightarrow 50mA$)

$V_{IN}=1.8V$

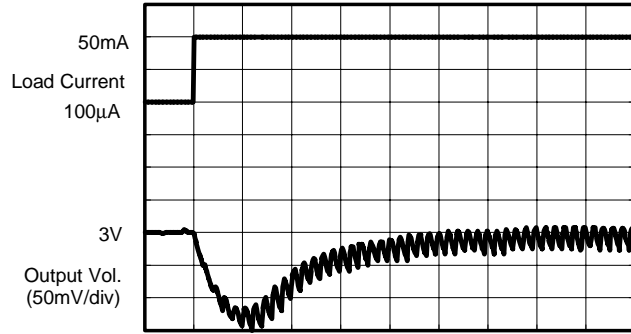

t (100µsec/div)

S-8323A30 ($I_{OUT}:50mA \rightarrow 100\mu A$)

$V_{IN}=1.8V$



t (5msec/dvi)

S-8327B30 ($I_{OUT}:100\mu A \rightarrow 100mA$)

$V_{IN}=1.8V$

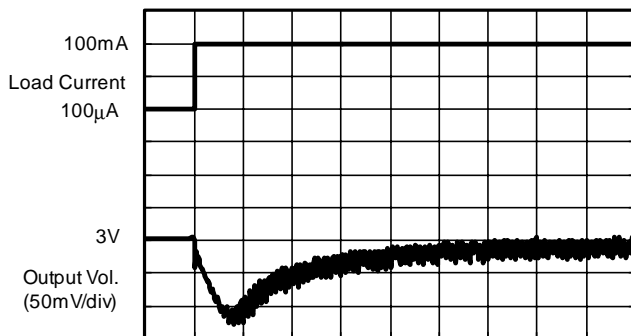

t (100µsec/div)

S-8327B30 ($I_{OUT}:100mA \rightarrow 100\mu A$)

$V_{IN}=1.8V$

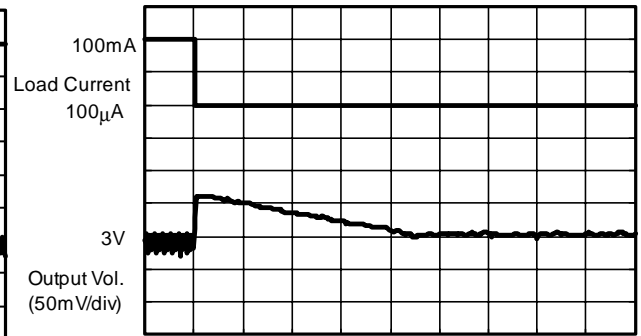

t (5msec/div)

There is no significant difference in load/power-voltage fluctuations between A, B, and H types.

4. Power Voltage Fluctuations

S8323A30 ($V_{IN}:1.8V \rightarrow 2.4V$)

$I_{OUT}=50mA$

S8323A30 ($V_{IN}:2.4V \rightarrow 1.8V$)

$I_{OUT}=50mA$

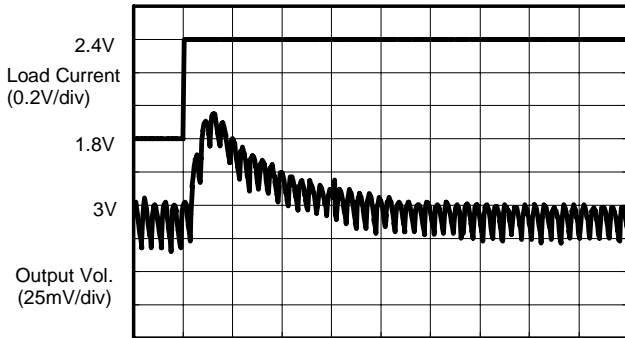

t (100µsec/div)

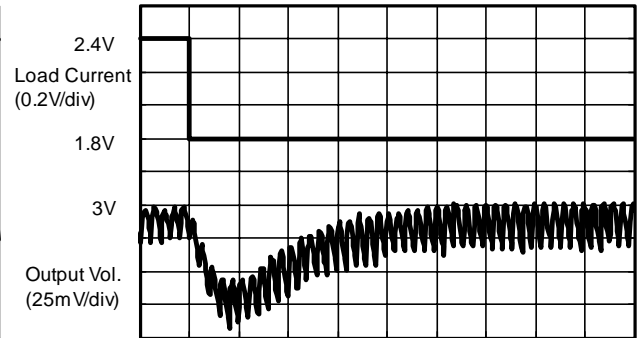

t (100µsec/div)

S8327B30 ($V_{IN}:1.8V \rightarrow 2.4V$)

$I_{OUT}=100mA$

S8327B30 ($V_{IN}:2.4V \rightarrow 1.8V$)

$I_{OUT}=100mA$

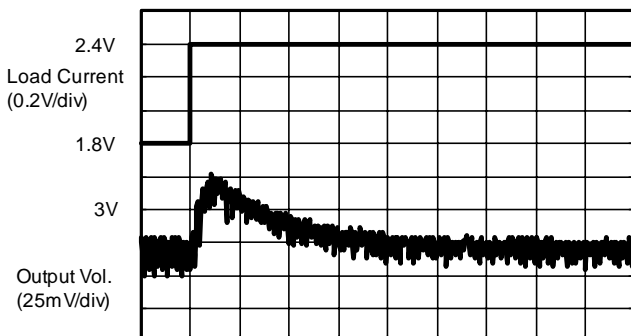

t (100µsec/div)

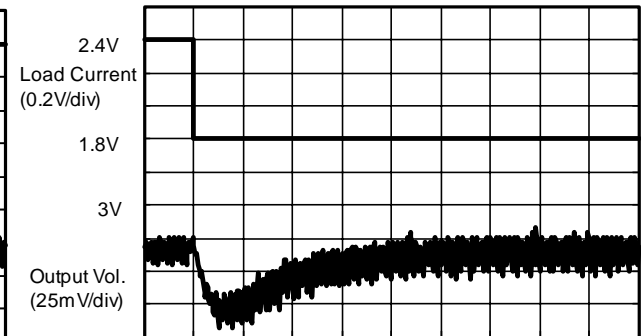

t (100µsec/div)

There is no significant difference in load/power-voltage fluctuations between A, B, and H types.

■ **Operation Start Voltage and Operation Holding Voltage Characteristics for Output Current**

(The characteristics measurement circuits are Standard Circuit(1) for S-8323A/H, Standard Circuit(2) for S-8327B, Standard Circuit(8) for S-8327H. The external parts are subject to the electrical properties of each A/B/H type.)

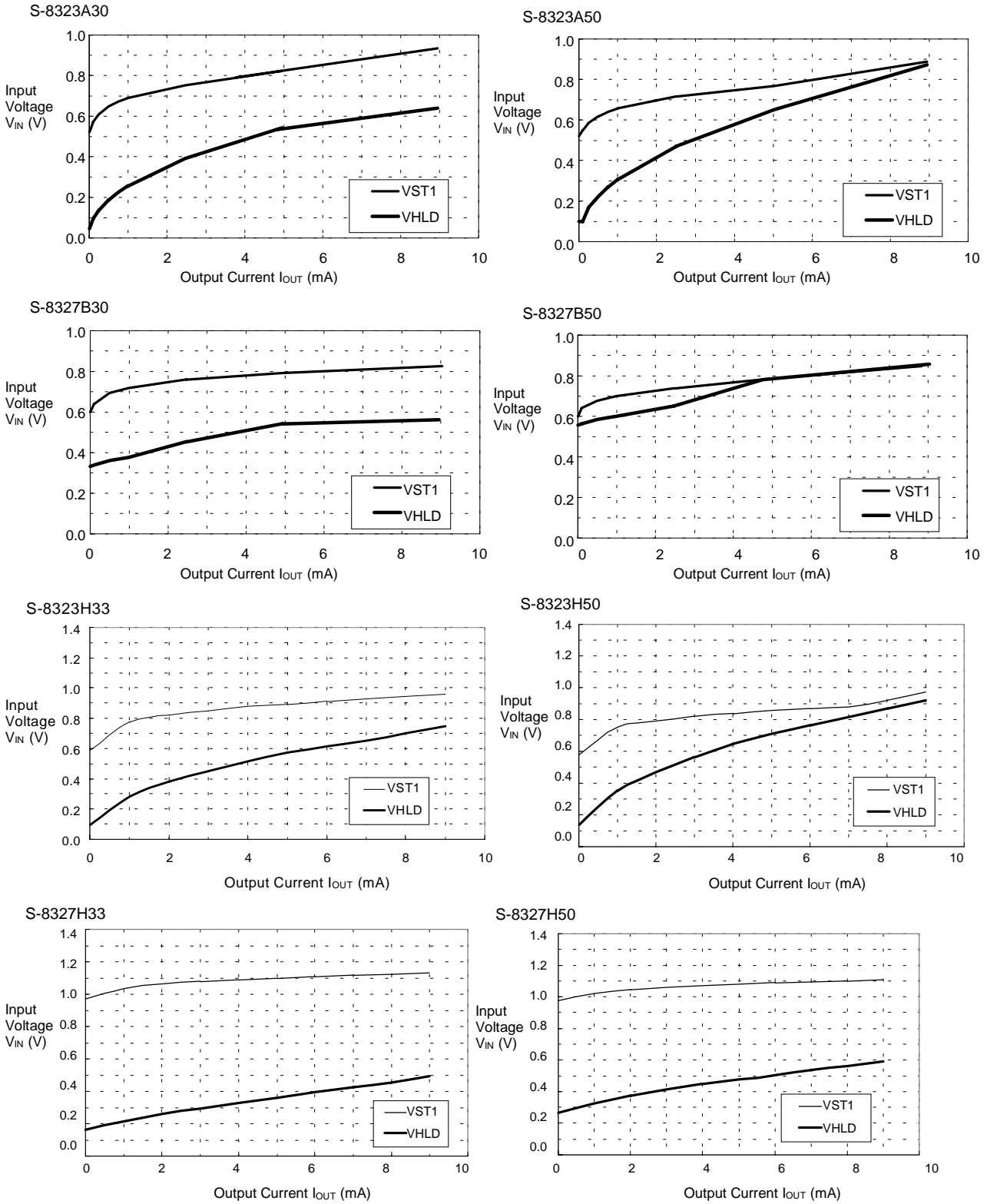

■ Input Voltage Characteristics for Input Current

(The characteristics measurement circuits are Standard Circuit(1) for S-8323A/H, Standard Circuit(2) for S-8327B, Standard Circuit(8) for S-8327H. The external parts are compatible with the specified conditions of electrical characteristics of Types A, B and H, respectively. The input current adopted for the measuring condition is the consumption current from V_{IN} under no load.)

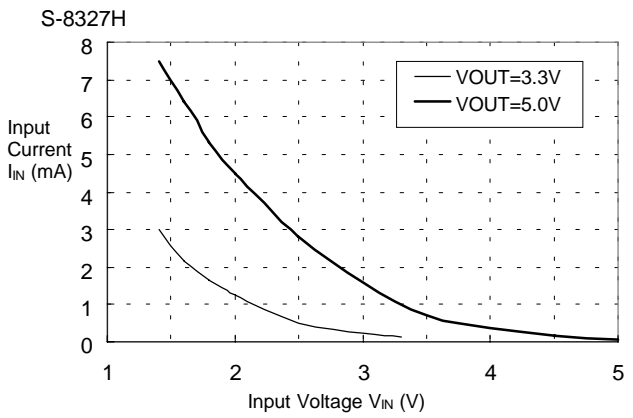
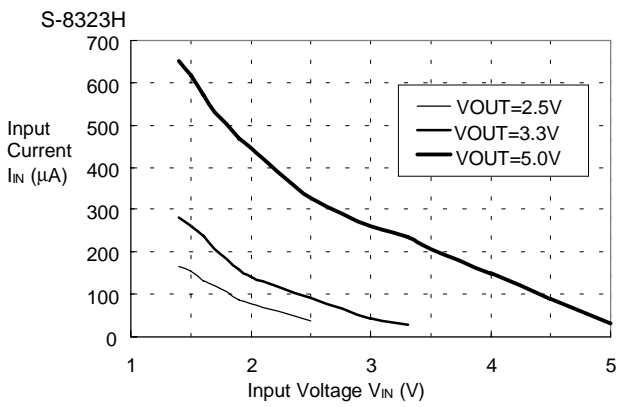
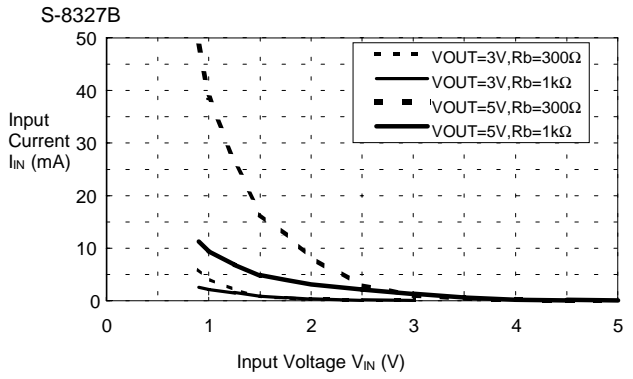
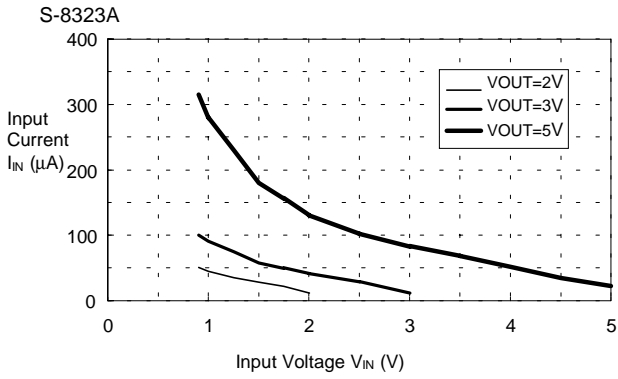

■ **Reference Data**

Use reference data to choose the external parts.

Reference data give you the procedure to choose the recommended external parts for various applications and its characteristics data.

1. Classification of Products and Inductors by Usage

The products are classified in general into built-in/external switching transistor(S-8323/7) types and low/high switching frequency(A,B/H) types.

Compared with built-in switching transistors, external switching transistors can yield larger output current but their efficiency decreases in a small output current range(especially less than 1mA).

Compared with low frequency models, the high frequency models can yield smaller external parts, in particular inductors, and smaller output ripple voltage. However, they need more than two alkaline-manganese battery cells(operation voltage increases from 0.9V to 1.4V).

And the efficiency decreases in a small output current range(especially less than 1mA).

The figures below summarize above features. Please refer to those figures when choosing your models.

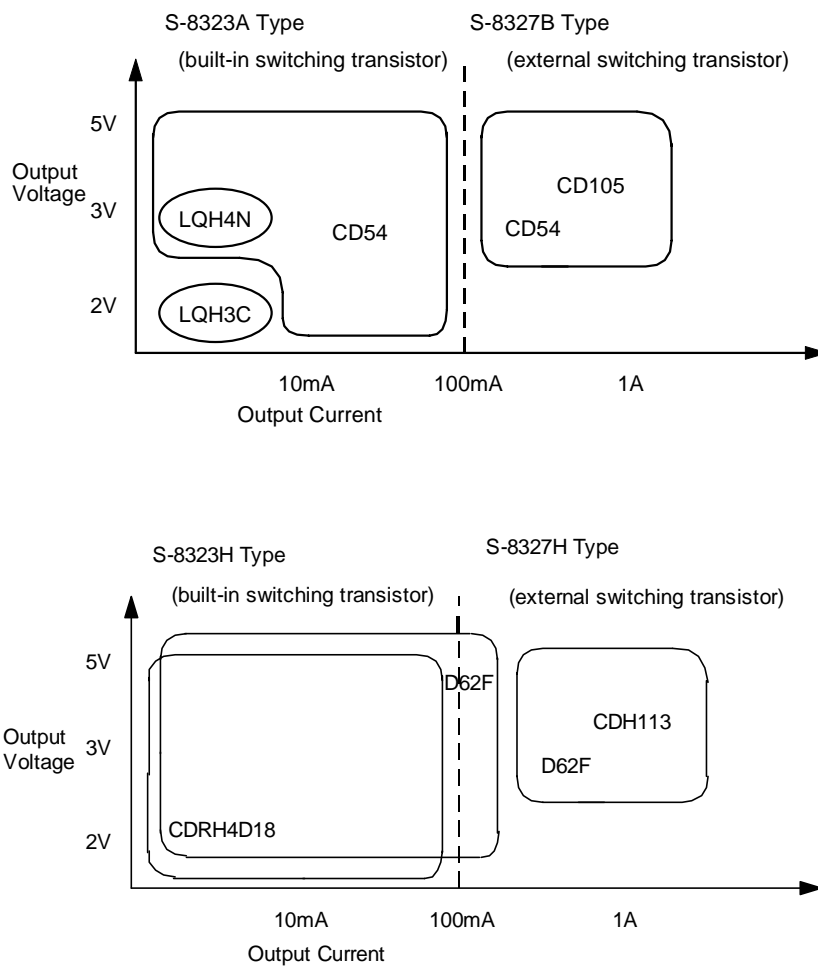
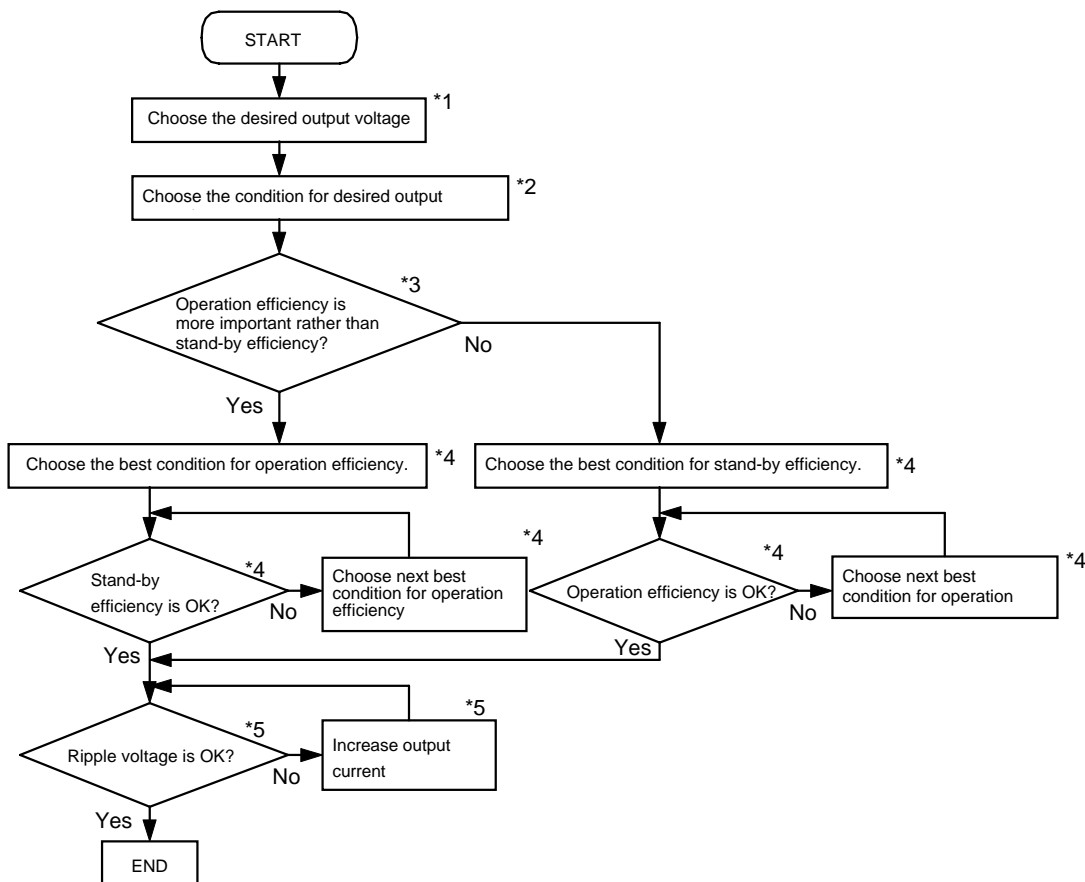

Figure 36 Classification of Inductors by Output Current

2. Procedure to choose the most suitable condition from reference data.

Please refer to the procedures shown below when choosing external parts based on the reference data.



- *1) Choose desired output voltage from conditions (1) to (29) shown in Table 1 and 2. When desired output voltage does not exist in Tables, choose the next higher voltage. For instance, when $V_{OUT}=3V$ for S-8323A, choose from conditions (3) to (6).
- *2) Choose all conditions from conditions chosen above for output current needed for input voltage (min) of the operational condition from "Reference data 1 (a) output voltage characteristics for output current". For instance, when 10mA output current is needed at $V_{IN}=0.9V$, choose from conditions (4) to (6).
- *3) Stand-by efficiency means the efficiency when the output current is small (approx. 100 μ A), operation efficiency means the efficiency when the output current is large (several mA). For instance, go to "YES" when operation efficiency is more important rather than stand-by efficiency.
- *4) Read the efficiency for input voltage and output current in operational condition from "Reference data 1 (b) efficiency characteristics for output current". For instance, when $V_{IN}=0.9V$ at $I_{OUT}=10mA$, the efficiency is max. (75%) in condition (6) in (4) to (6). There is no difference between conditions (4) to (6) when the output current is 100 μ A at stand-by condition. Therefore, choose condition (6).
- *5) Read the ripple voltage under the operational condition selected above from "Reference data 2 ripple voltage characteristics for output current". For instance, when condition (6) is selected above, the ripple voltage is 12mV at $V_{IN}=0.9V$ and $I_{OUT}=10mA$.

3. Reference Data for External Components

Table 1 S-8323 Series

Condition	Product type	V _{OUT}	Model name of L	L value	D	C _{OUT}
(1)	A	2V	LQH3C	220μH	MA720	22μF
(2)	A	2V	LQH4N	220μH	↑	↑
(3)	A	3V	LQH4N	220μH	↑	↑
(4)	A	3V	CD54	47μH	↑	↑
(5)	A	3V	CD54	100μH	↑	↑
(6)	A	3V	CD54	220μH	↑	↑
(7)	A	5V	CD54	47μH	↑	↑
(8)	A	5V	CD54	100μH	↑	↑
(9)	A	5V	CD54	220μH	↑	↑
(10)	H	2.5V	CDRH4D18	22μH	↑	↑
(11)	H	2.5V	D62F	22μH	↑	↑
(12)	H	3.3V	CDRH4D18	22μH	↑	↑
(13)	H	3.3V	D62F	10μH	↑	↑
(14)	H	3.3V	D62F	22μH	↑	↑
(15)	H	5V	CDRH4D18	22μH	↑	↑
(16)	H	5V	D62F	10μH	↑	↑
(17)	H	5V	D62F	22μH	↑	↑

Table 2 S-8327 Series

Condition	Product type	V _{OUT}	Model name of L	L value	Model name of external transistor	Rb	Cb	D	C _{OUT}
(18)	B	3V	CD105	22μH	2SD1628G	300Ω	0.01μF	MA735	47μF×2
(19)	B	3V	CD105	22μH	↑	1KΩ	0.0022μF	MA735	47μF×2
(20)	B	3V	CD54	47μH	↑	1KΩ	0.0022μF	MA720	47μF
(21)	B	3V	D75C	47μH	↑	1KΩ	0.0022μF	MA720	47μF
(22)	B	5V	CD105	22μH	↑	300Ω	0.01μF	MA735	47μF×2
(23)	B	5V	CD105	22μH	↑	1KΩ	0.0022μF	MA735	47μF×2
(24)	B	5V	CD54	47μH	↑	1KΩ	0.0022μF	MA720	47μF
(25)	B	5V	D75C	47μH	↑	1KΩ	0.0022μF	MA720	47μF
(26)	H	3.3V	D62F	6.8μH	TN0200T	—	—	MA720	100μF
(27)	H	3.3V	CDH113	10μH	NDS335H	—	—	MA735	↑
(28)	H	5V	D62F	6.8μH	TN0200T	—	—	MA720	↑
(29)	H	5V	CDH113	10μH	NDS335N	—	—	MA735	↑

The properties of external parts are shown below.

Table 3

Part	Product name	Manufacturer's name	L value	DC resistance	Max allowable current	Diameter	Height
Inductor	CD105	Sumida	22μF	0.10Ω	1.95A	10.0mm	5.4mm
	CD54	↑	47μF	0.37Ω	0.72A	5.8mm	4.5mm
	↑	↑	100μF	0.70Ω	0.52A	↑	↑
	↑	↑	220μF	1.57Ω	0.35A	↑	↑
	CDRH4D18	↑	22μH	0.397Ω	0.41A	4.5mm	2.0mm
	CDH113	↑	10μH	0.054Ω	2.00A	11.0mm	3.7mm
	LQH4N	Murata	220μF	5.40Ω	0.11A	4.5mm	2.6mm
	LQH3C	↑	220μF	8.40Ω	0.07A	3.2mm	2.0mm
	D75C	Toko	47μF	0.20Ω	0.76A	7.6mm	5.1mm
	↑	↑	100μH	0.40Ω	0.50A	↑	↑
	D62F	↑	6.8μH	0.075Ω	1.36A	6.0mm	2.7mm
	↑	↑	10μH	0.110Ω	1.20A	↑	↑
↑	↑	22μH	0.247Ω	0.70A	↑	↑	
Diode (Schottky)	MA720	Matsushita	forward current 500mA(at V _F =0.55V)				
	MA735	↑	forward current 1A(at V _F =0.5V)				
Output capacitor	F93	Nichicon	Surface Mount Tantlum electrolytic capacitor				
External transistor	2SD1628G	Sanyo	bipolar NPN transistor				
	TN0200T	Temic Siliconics	MOS FET Nch transistor				
	NDS335N	National Semiconductor	MOS FET Nch transistor				

4. Reference Data 1

Output voltage characteristics for output current and (b) efficiency characteristics for output current under conditions (1) to (29) shown in Tables 1 and 2 are shown below.

(1)S-8323A20(LQH3C:220μH)

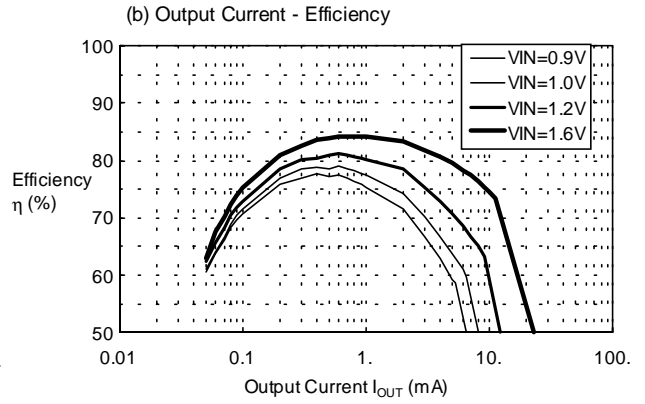
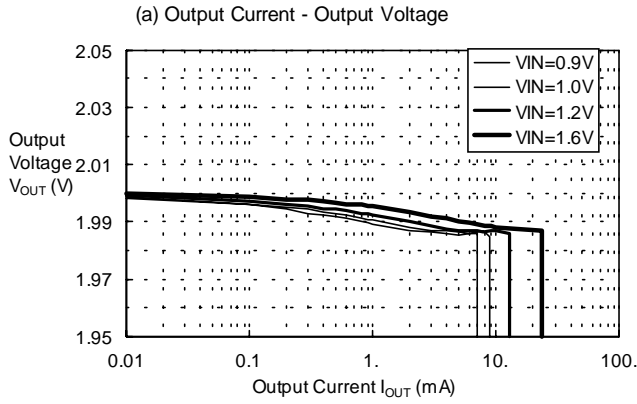

(2)S-8323A20(LQH4N:220μH)

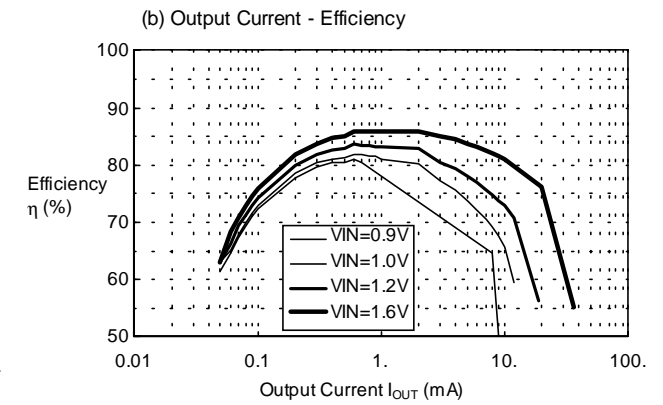
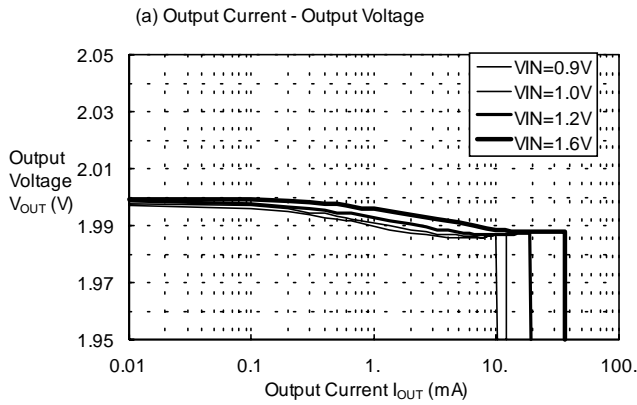

(3)S-8323A30(LQH4N:220μH)

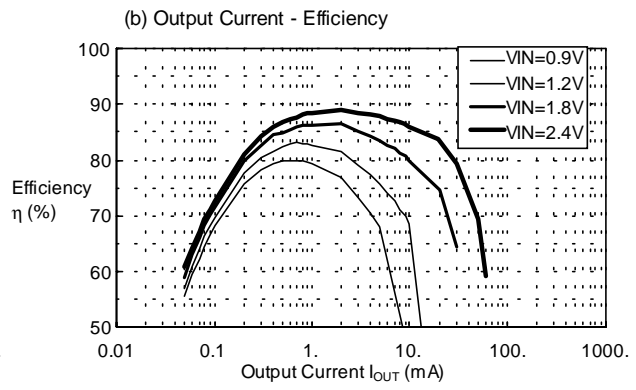
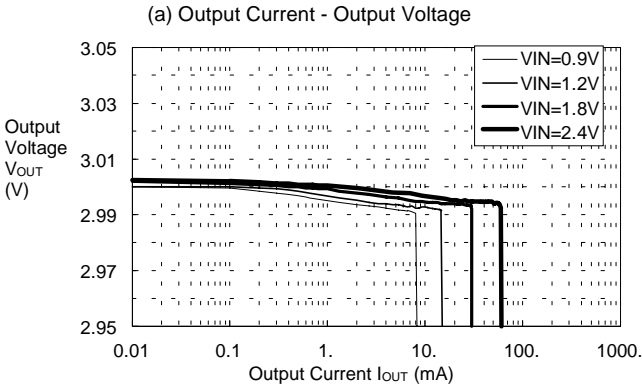

(4)S-8323A30(CD54:47μH)

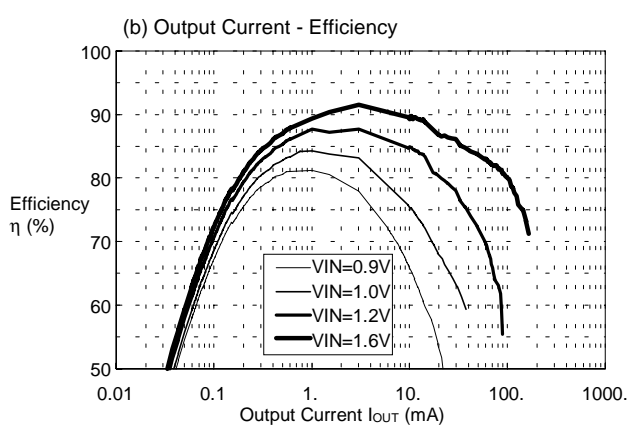
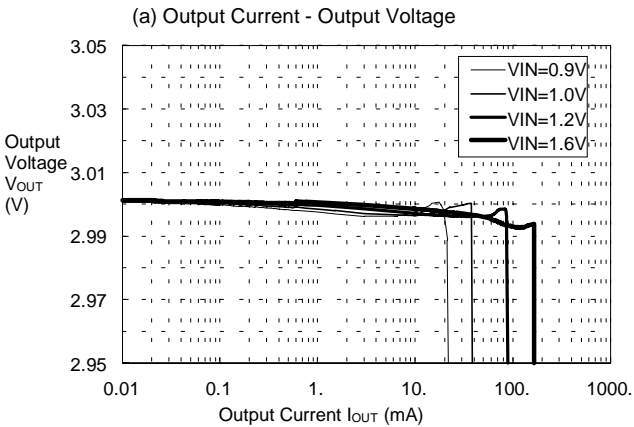

(5)S-8323A30(CD54:100μH)

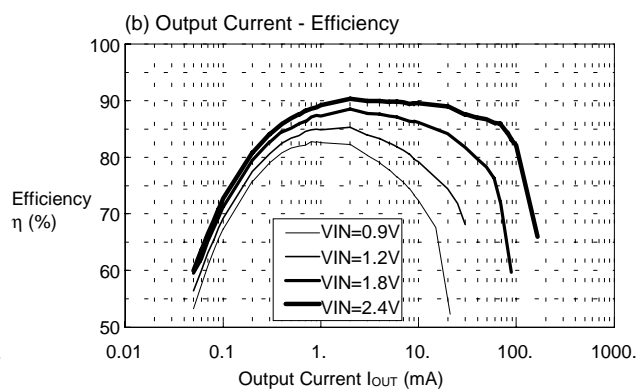
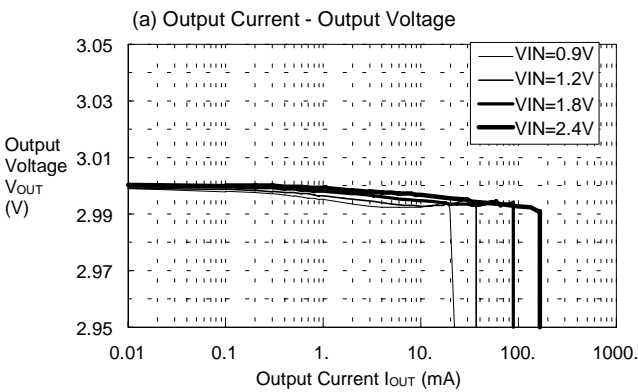

(6)S-8323A30(CD54:220μH)

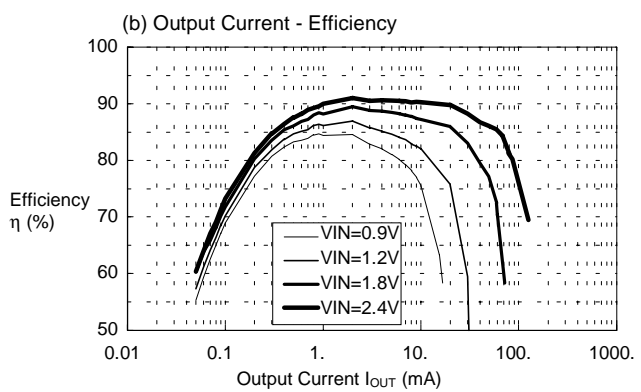
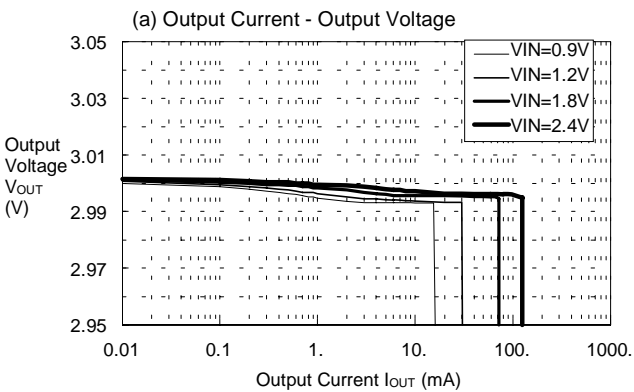

(7)S-8323A50(CD54:47μH)

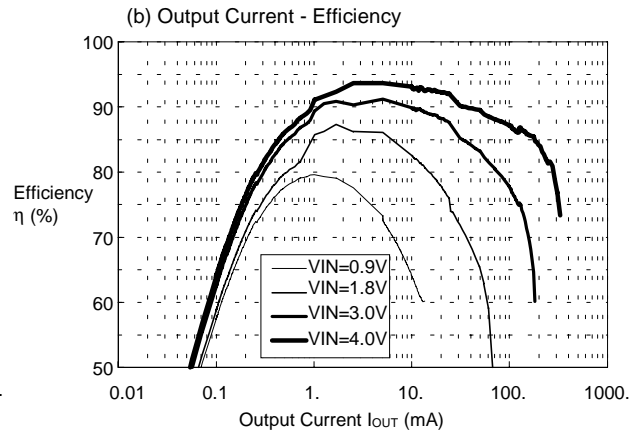
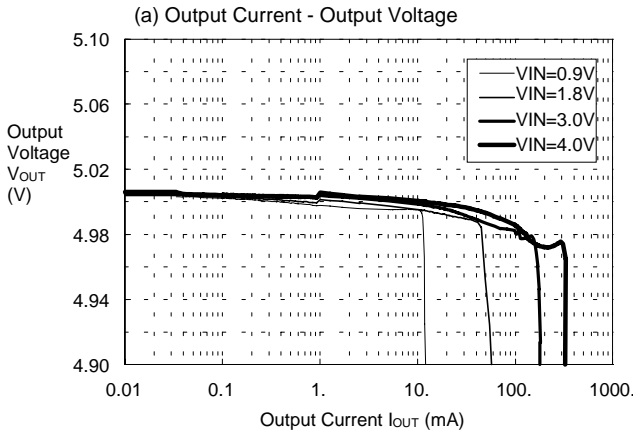

(8)S-8323A50(CD54:100μH)

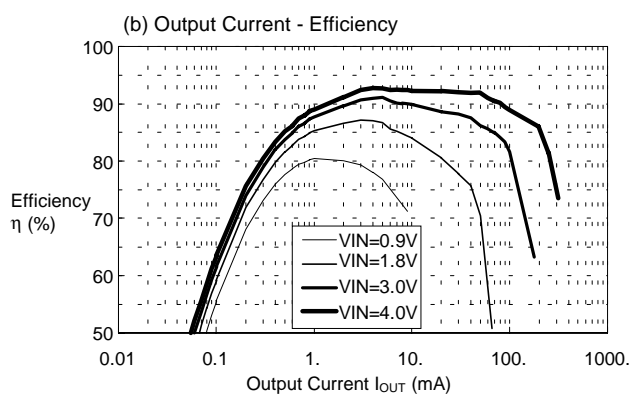
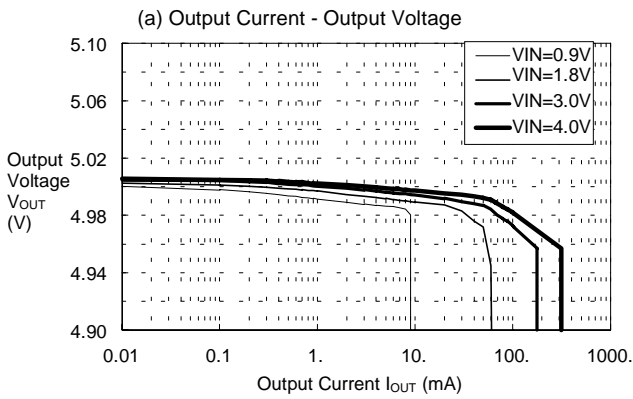

(9)S-8323A50(CD54:220μH)

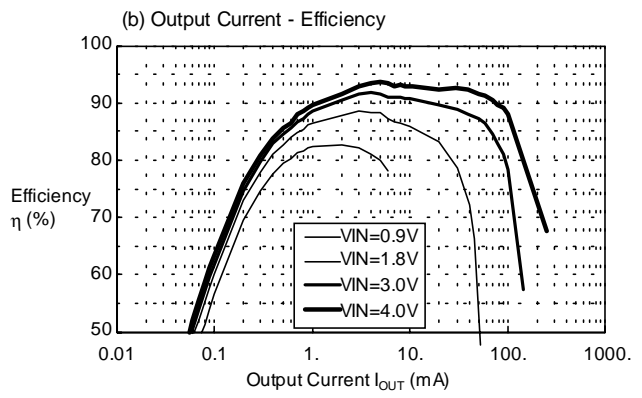
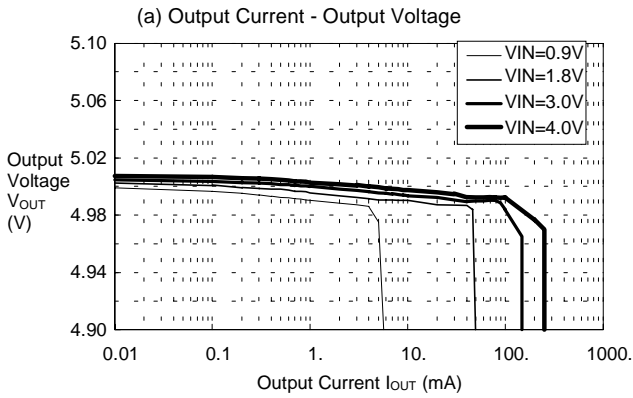

(10)S-8323H25(CDRH4D18:22μH)

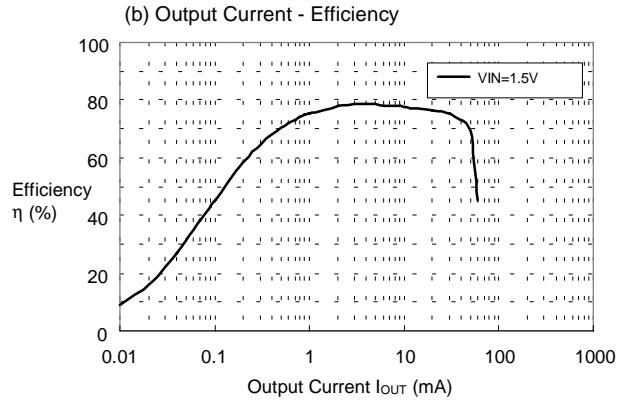
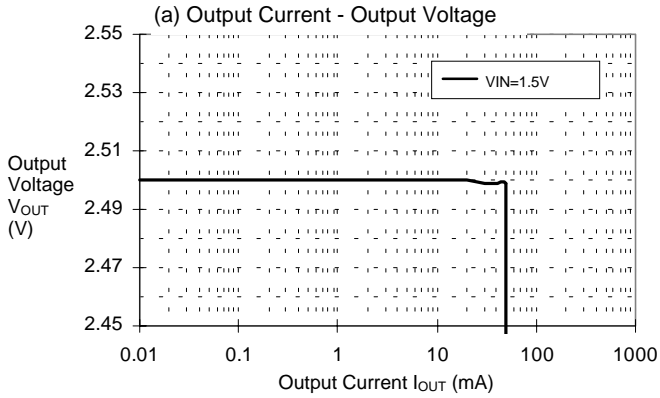

(11)S-8323H25(D62F:22μH)

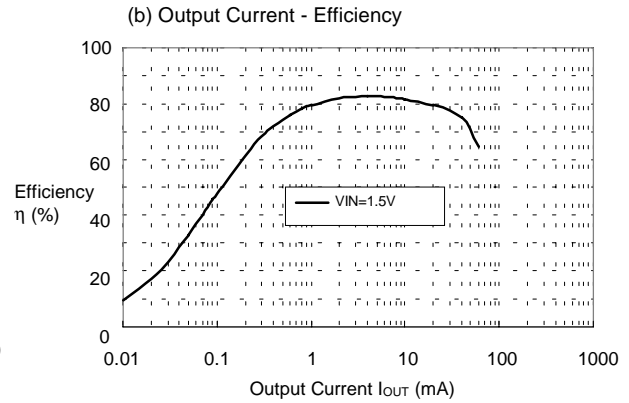
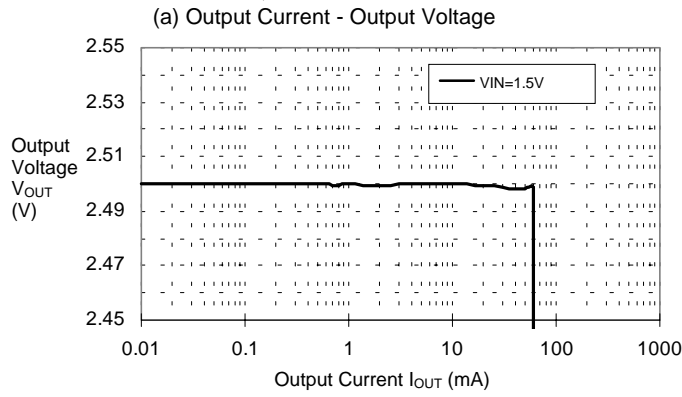

(12)S-8323H33(CDRH4D18:22μH)

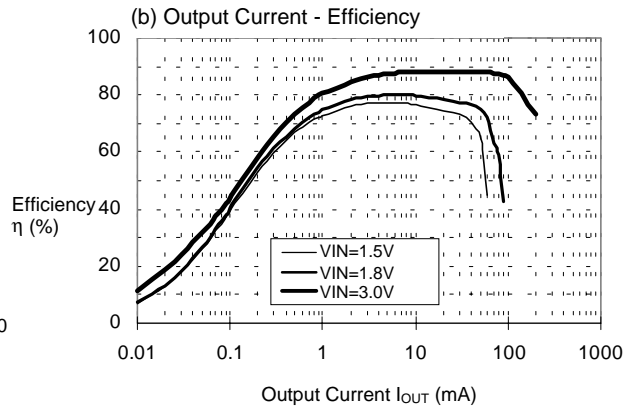
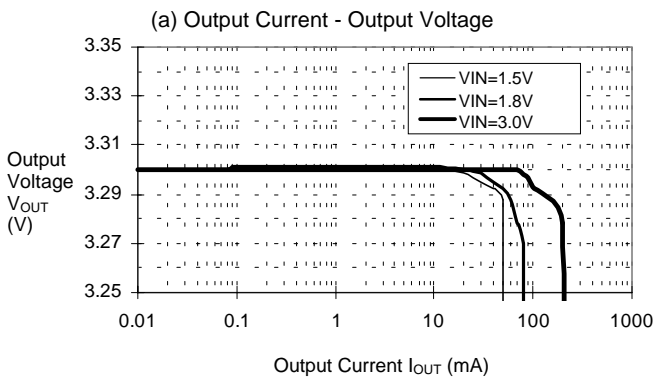

(13)S-8323H33(D62F:10μH)

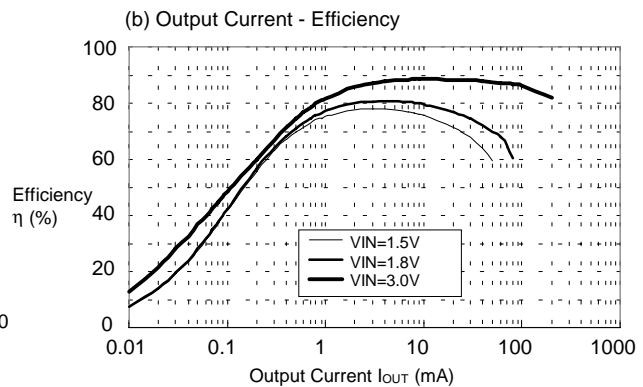
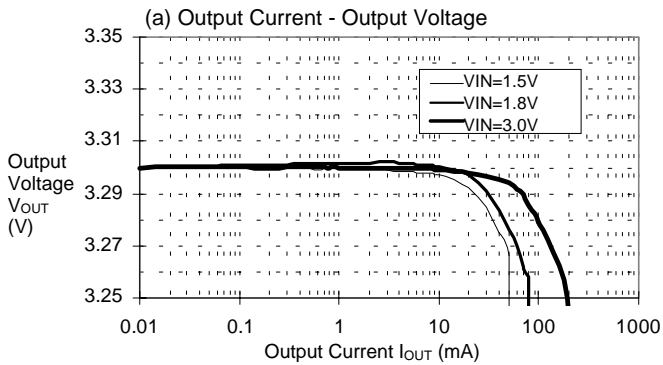

(14)S-8323H33(D62F:22μH)

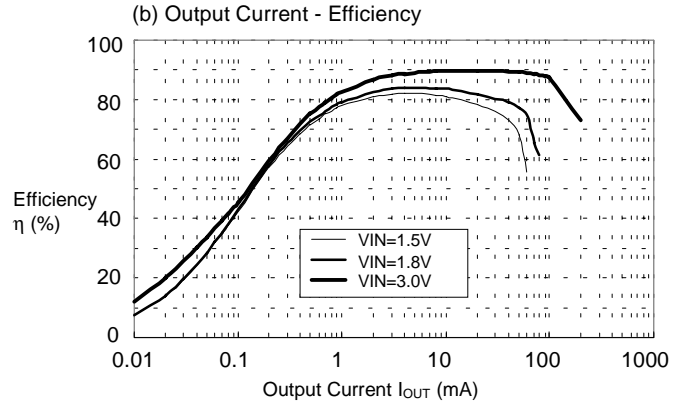
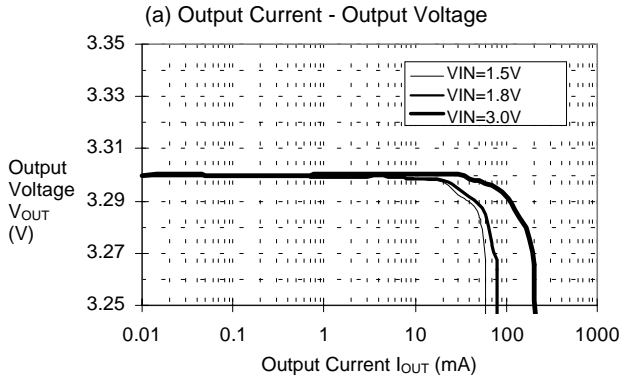

(15)S-8323H50(CDRH 4D18:22μH)

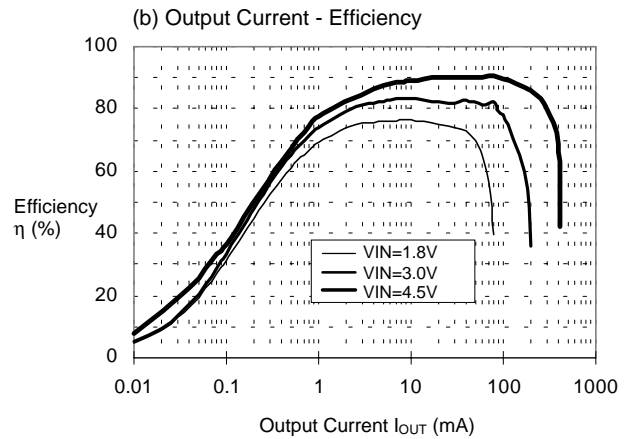
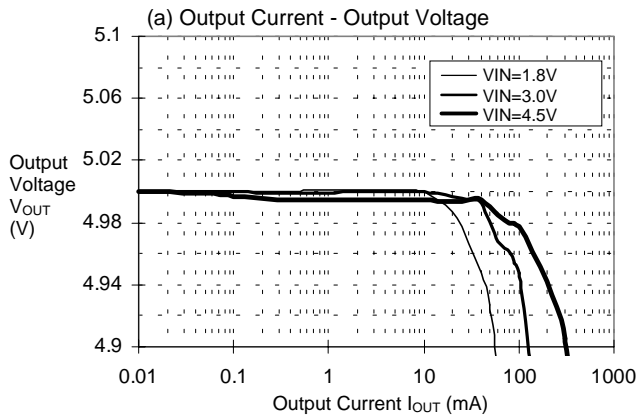

(16)S-8323H50(D62F:10μH)

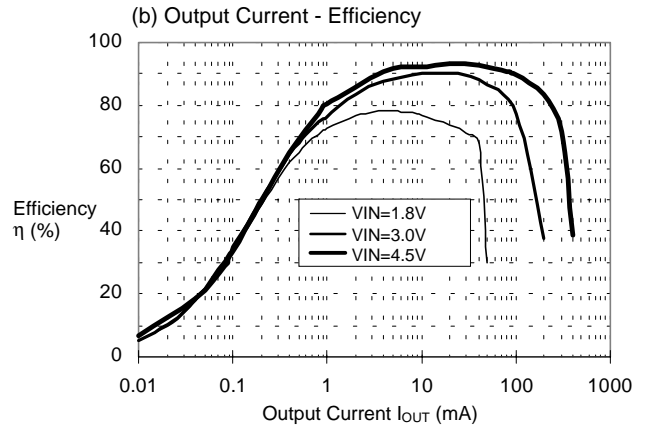
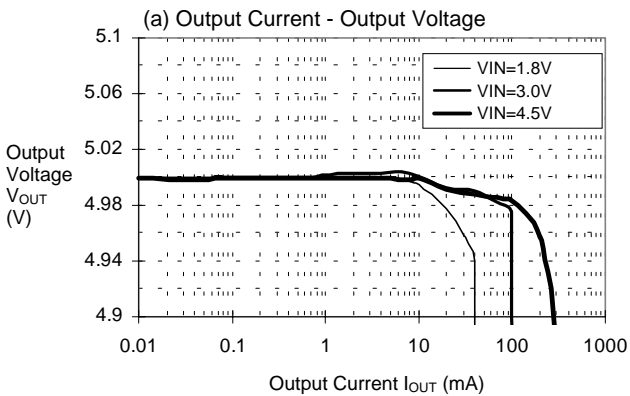

(17)S-8323H50(D62F:22μH)

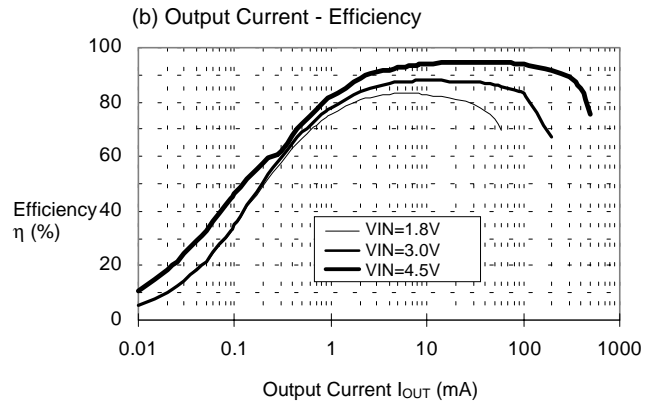
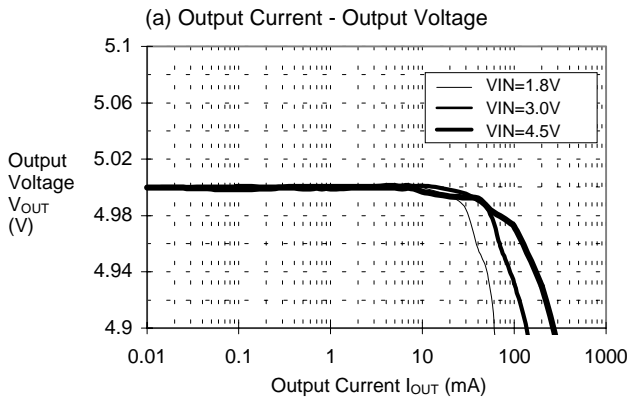

(18)S-8327B30(CD105:22 μ H,Rb=300 Ω ,Cb=0.01 μ F)

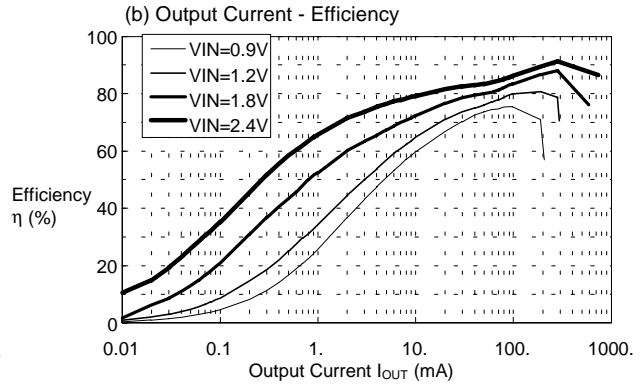
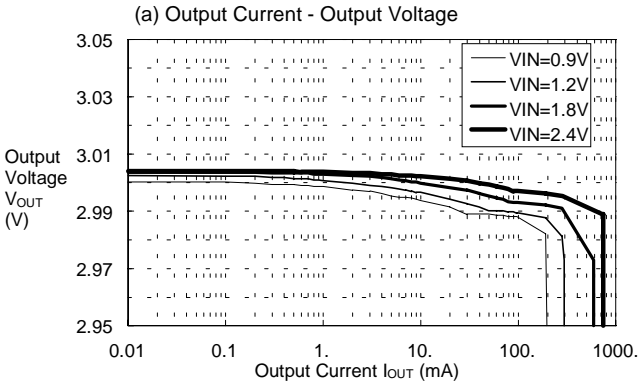

(19)S-8327B30(CD105:22 μ H,Rb=1k Ω ,Cb=0.0022 μ F)

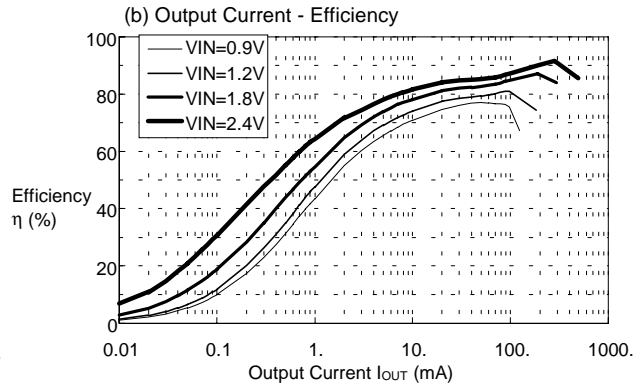
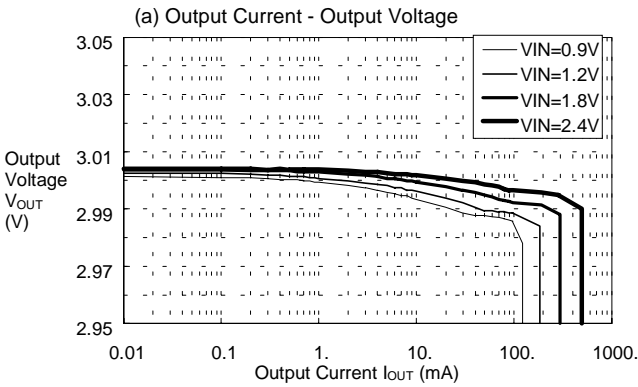

(20)S-8327B30(CD54:47 μ H,Rb=1k Ω ,Cb=0.0022 μ F)

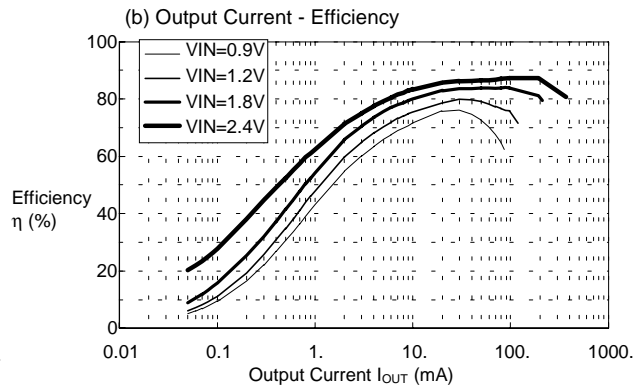
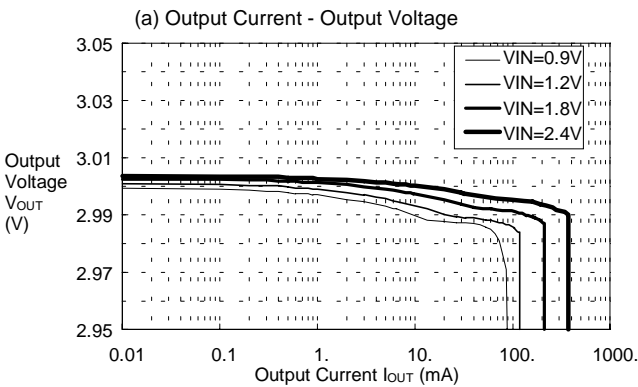

(21)S-8327B30(D75C:47 μ H,Rb=1k Ω ,Cb=0.0022 μ F)

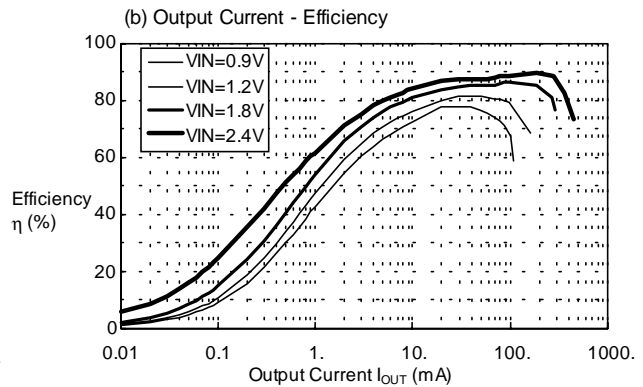
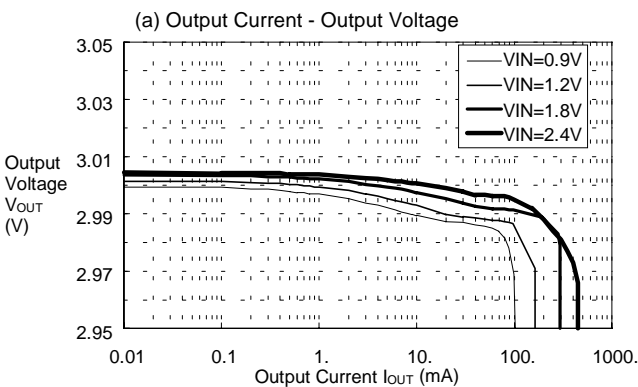

(22)S-8327B50(CD105:22 μ H,Rb=300 Ω ,Cb=0.01 μ F)

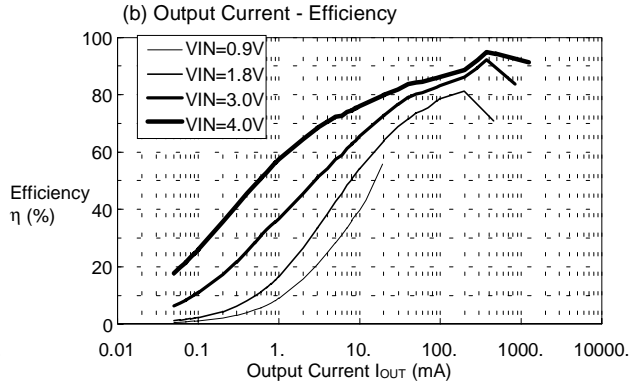
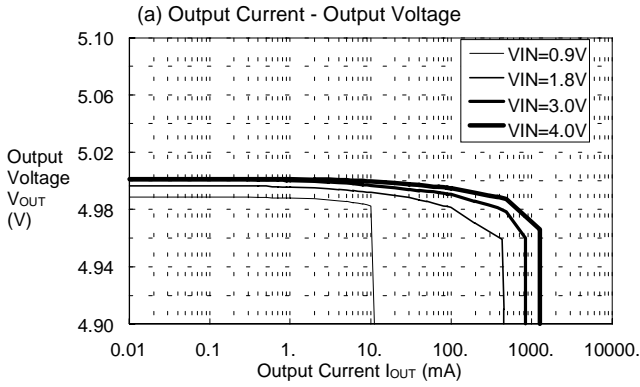

(23)S-8327B50(CD105:22 μ H,Rb=1k Ω ,Cb=0.0022 μ F)

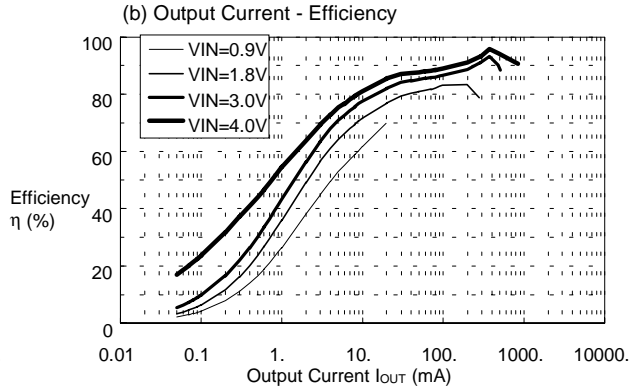
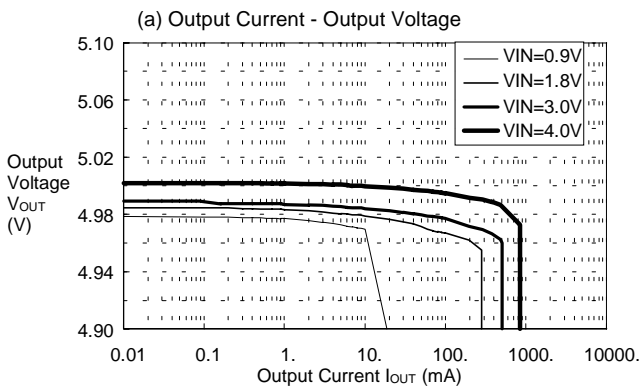

(24)S-8327B50(CD54:47 μ H,Rb=1k Ω ,Cb=0.0022 μ F)

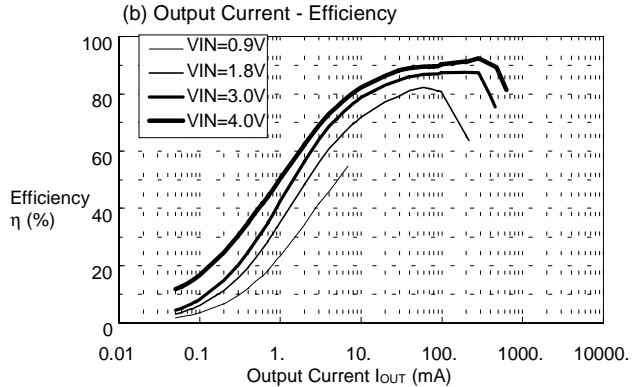
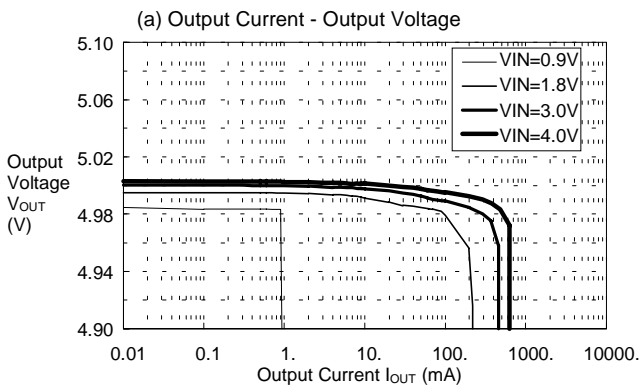

(25)S-8327B50(D75C:47 μ H,Rb=1k Ω ,Cb=0.0022 μ F)

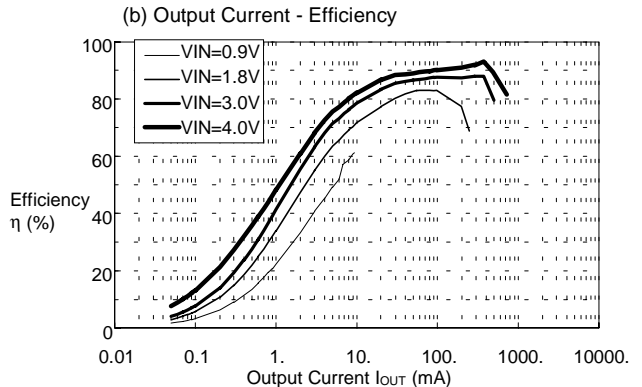
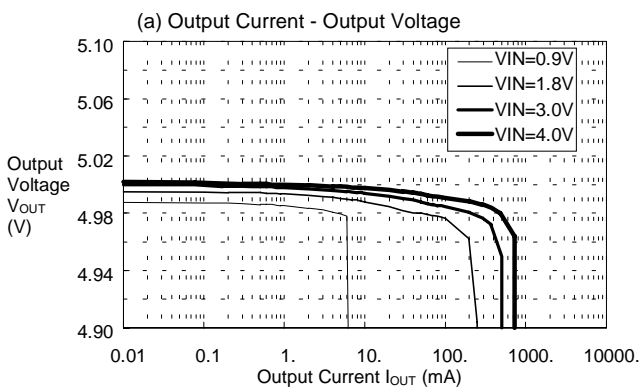

(26)S-8327H33(D62F:6.8μH)

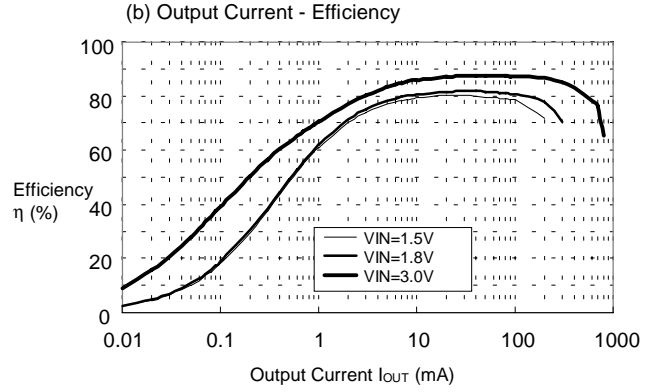
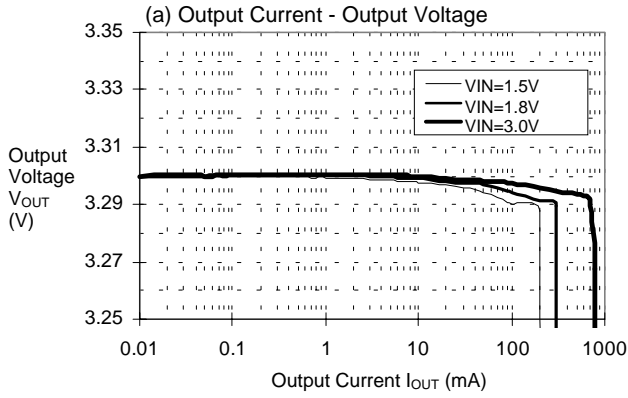

(27)S-8327H33(CDH113:10μH)

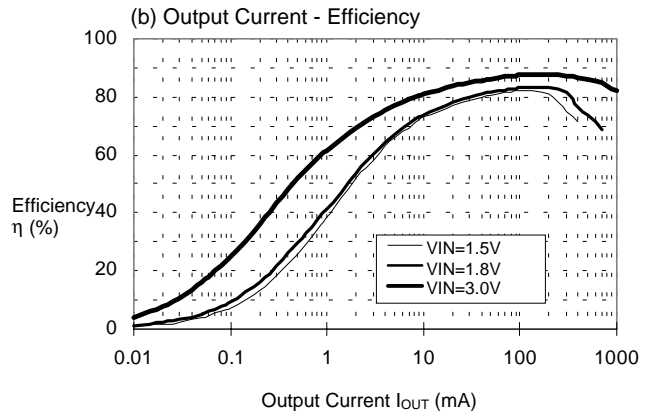
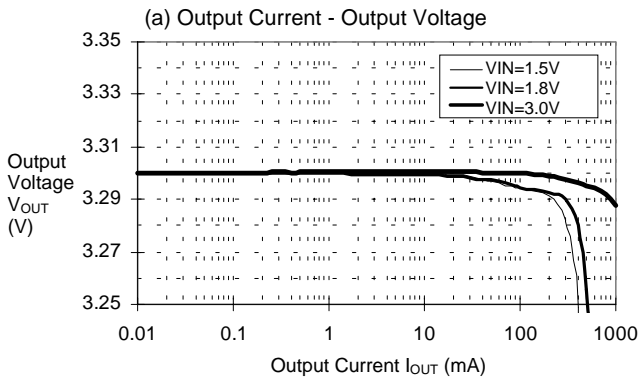

(28)S-8327H50(D62F:6.8μH)

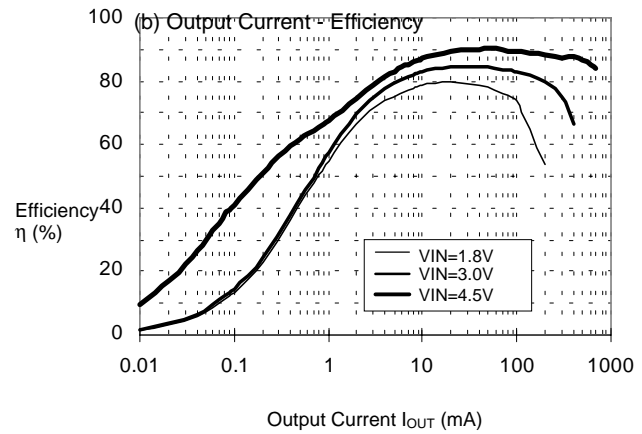
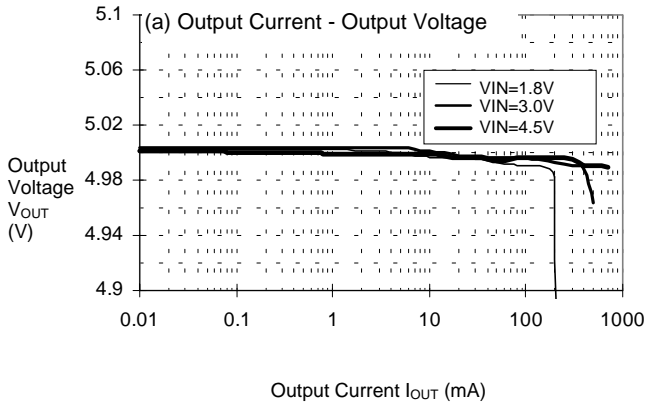

(29)S-8327H50(CDH113:10μH)

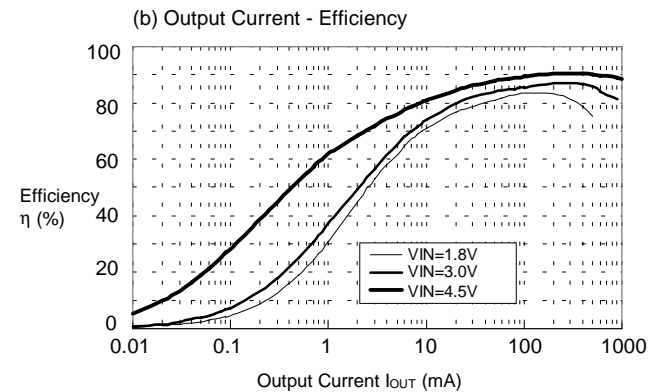
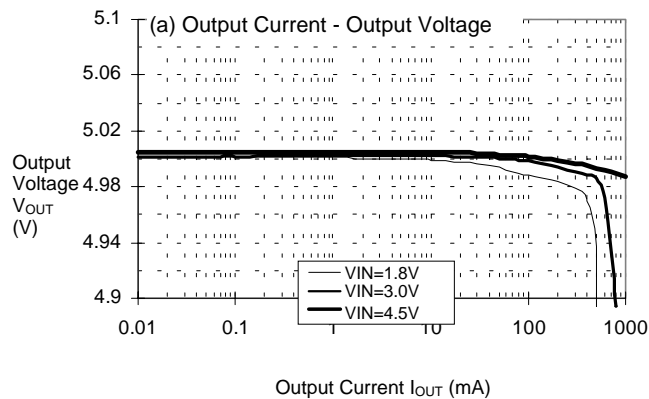

5. Reference Data 2

The ripple voltage characteristics data is shown below:

(1)S-8323A20
(LQH3C:220 μ H,C_{OUT}:22 μ F)
Similar to (2)

(2)S-8323A20
(LQH4N:220 μ H,C_{OUT}:22 μ F)

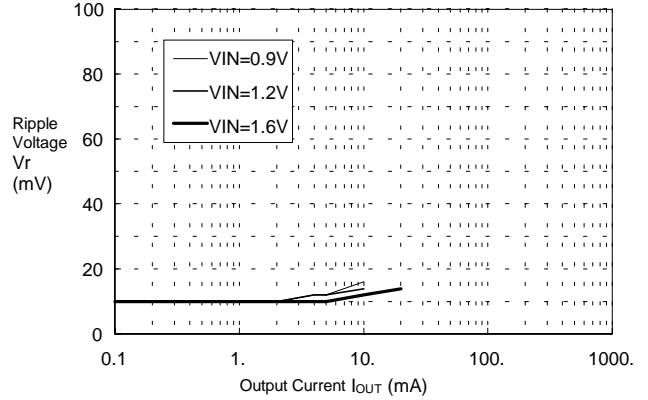

(3)S-8323A30
(LQH4N:220 μ H,C_{OUT}:22 μ F)
Similar to (6)

(4)S-8323A30
(CD54:47 μ H,C_{OUT}:22 μ F)

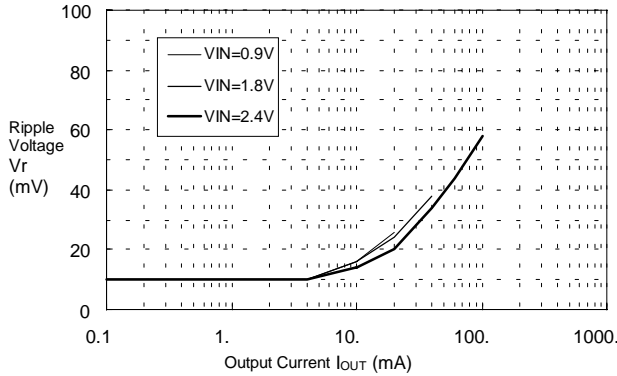

(7)S-8323A50
(CD54:47 μ H,C_{OUT}:22 μ F)

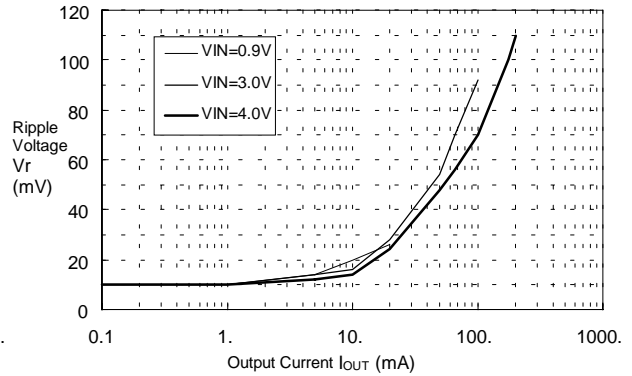

(5)S-8323A30
(CD54:100 μ H,C_{OUT}:22 μ F)

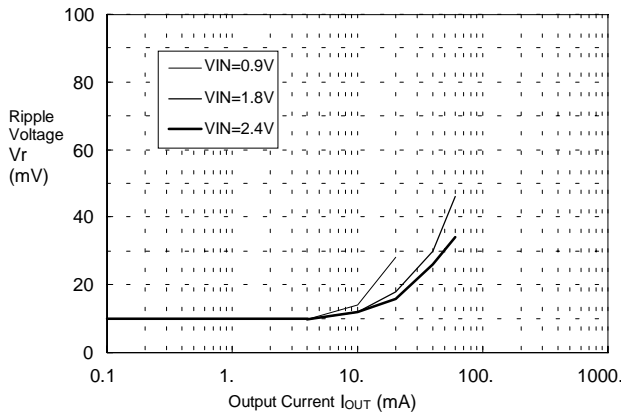

(8)S-8323A50
(CD54:100 μ H,C_{OUT}:22 μ F)

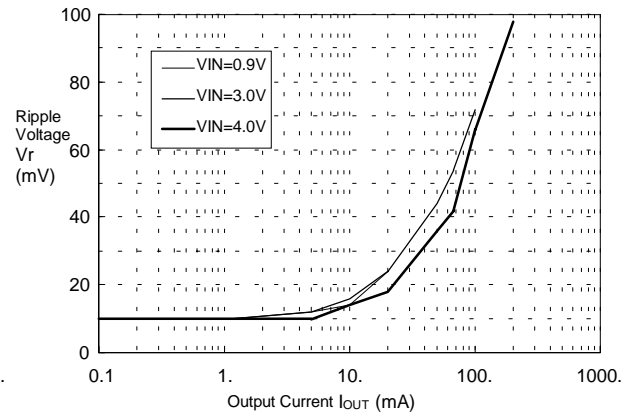

(6)S-8323A30
(CD54:220 μ H,C_{OUT}:22 μ F)

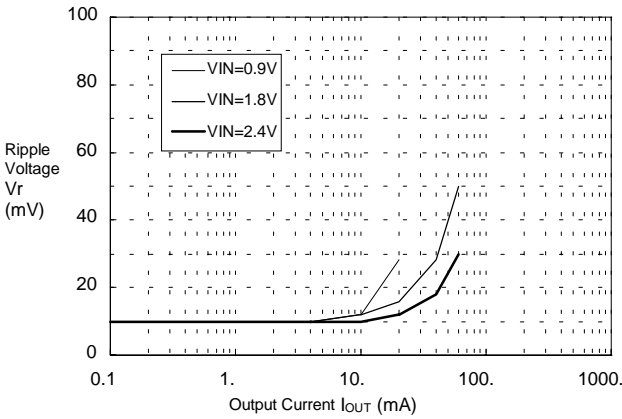

(9)S-8323A50
(CD54:220 μ H,C_{OUT}:22 μ F)

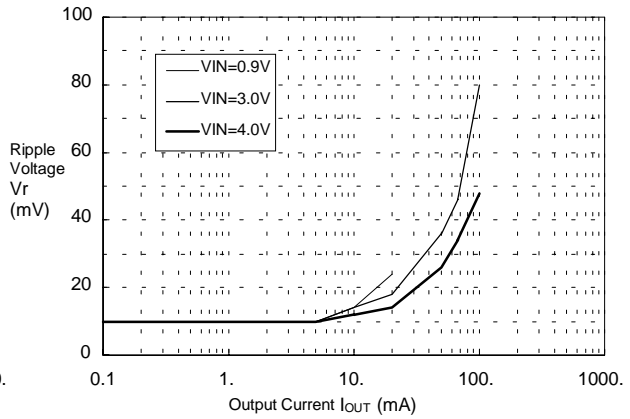

(11)S-8323H25
(D62F:22 μ H,C_{OUT}:22 μ F)

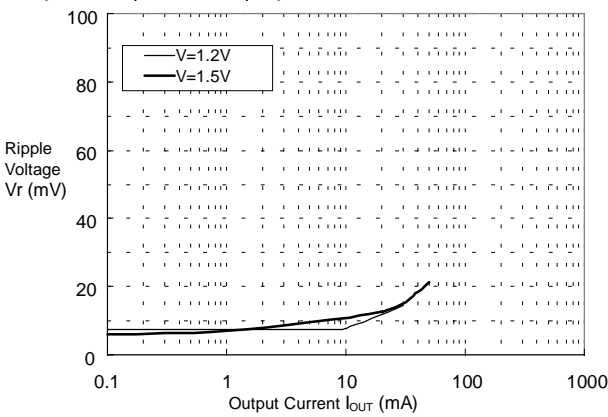

(14)S-8323H33
(D62F:22 μ H,C_{OUT}:22 μ F)

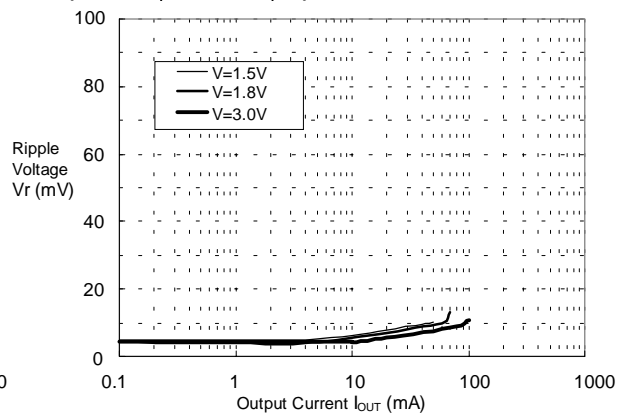

(17)S-8323H50
(D62F:22 μ H,C_{OUT}:22 μ F)

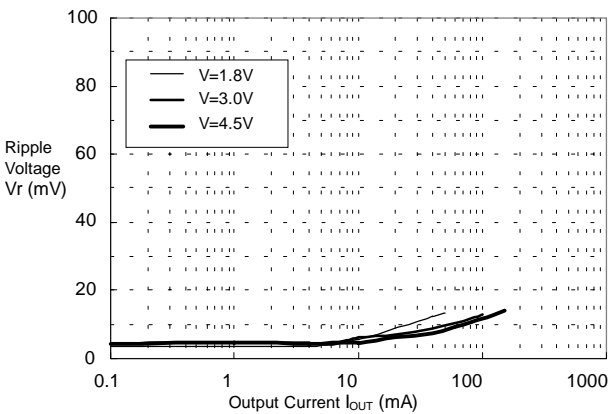

(18)(11)S-8327B30
(CD105:22 μ H,C_{OUT}:47 μ F \times 2)

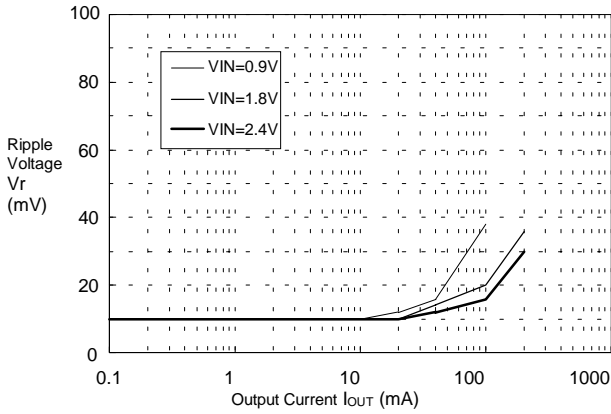

(22)(23)S-8327B50
(CD105:22 μ H,C_{OUT}:47 μ F \times 2)

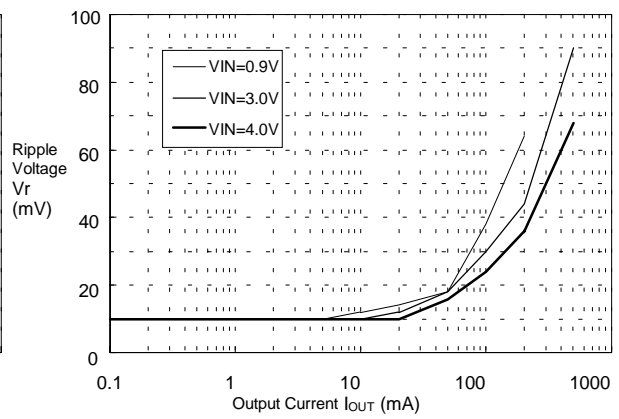

(20)S-8327B30
(CD54:47 μ H,C_{OUT}:47 μ F)

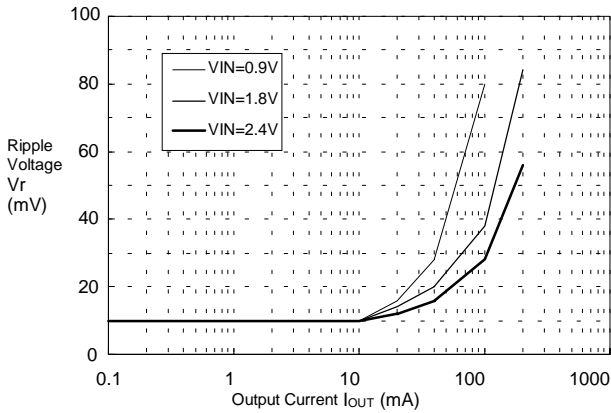

(24)S-8327B50
(CD54:47 μ H,C_{OUT}:47 μ F)

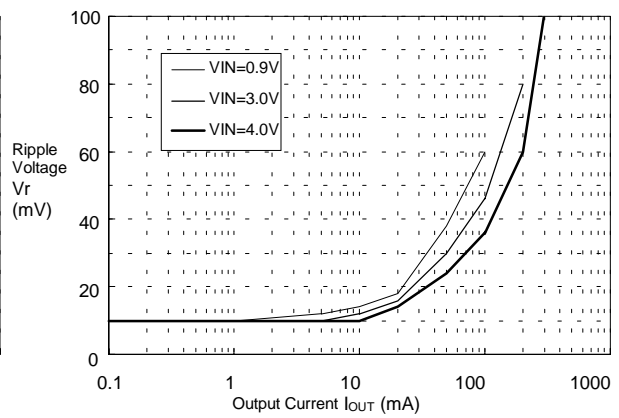

(21)S-8327B30
(D75C:47 μ H,C_{OUT}:47 μ F)
Similar to (20)

(25)S-8327B50
(D75C:47 μ H,C_{OUT}:47 μ F)
Similar to (24)

(27)S-8327H33
(CDH113:10 μ H,C_{OUT}:100 μ F)

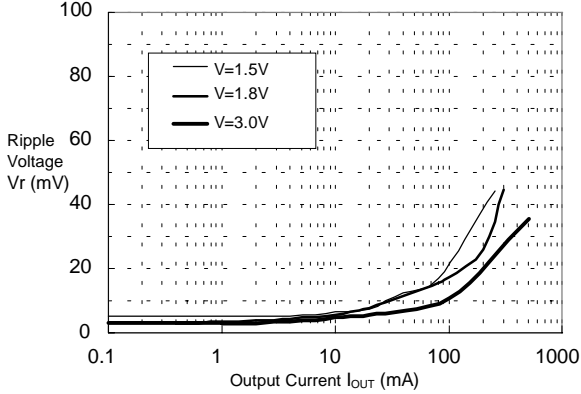

(29)S-8327H50
(CDH113:10 μ H,C_{OUT}:100 μ F)

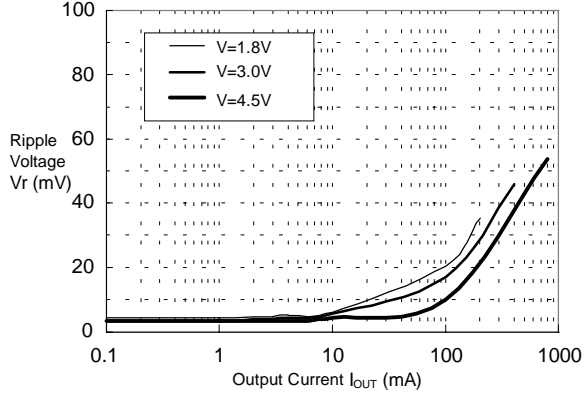

● Dimensions 外形図

Unit : mm

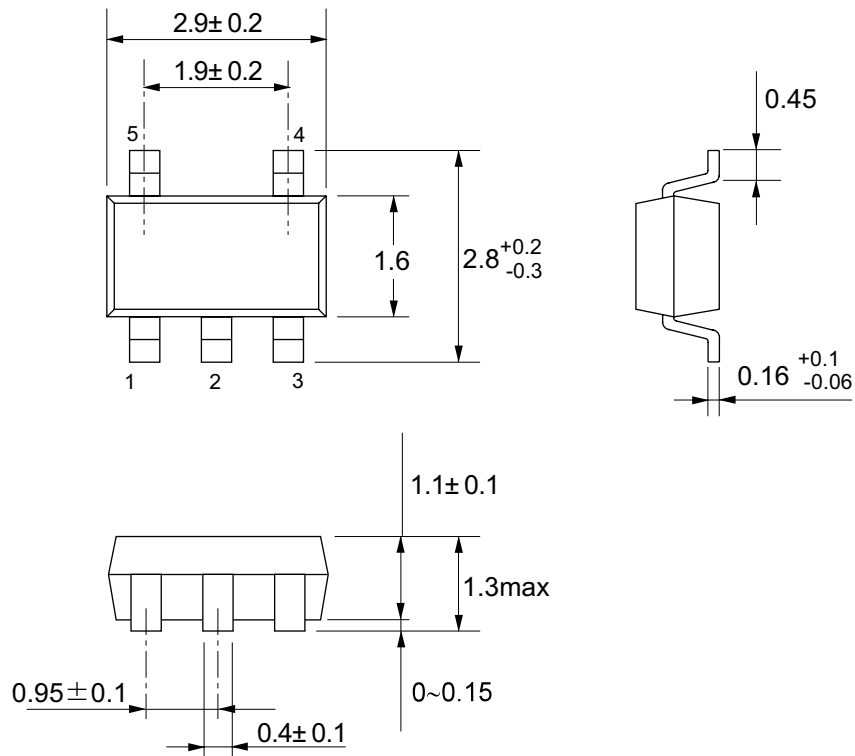

No. : MP005-A-P-SD-1.1

● Taping Specifications テーピング図

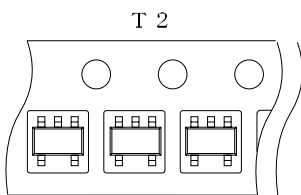
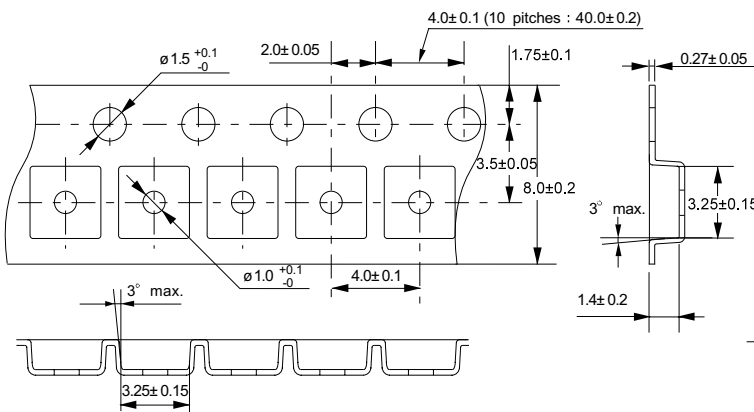

Feed direction
引き出し方向

No. : MP005-A-C-SD-1.0

● Reel Specifications リール図

3000 pcs./reel

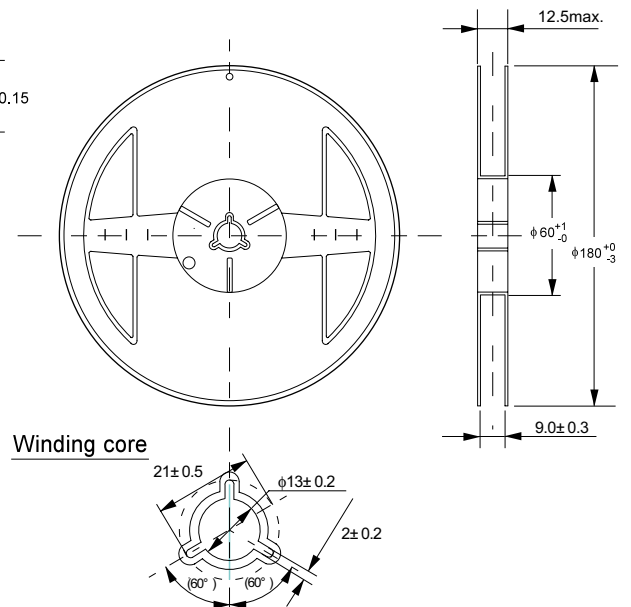

Winding core

No. : MP005-A-R-SD-1.0

● Dimensions

Unit:mm

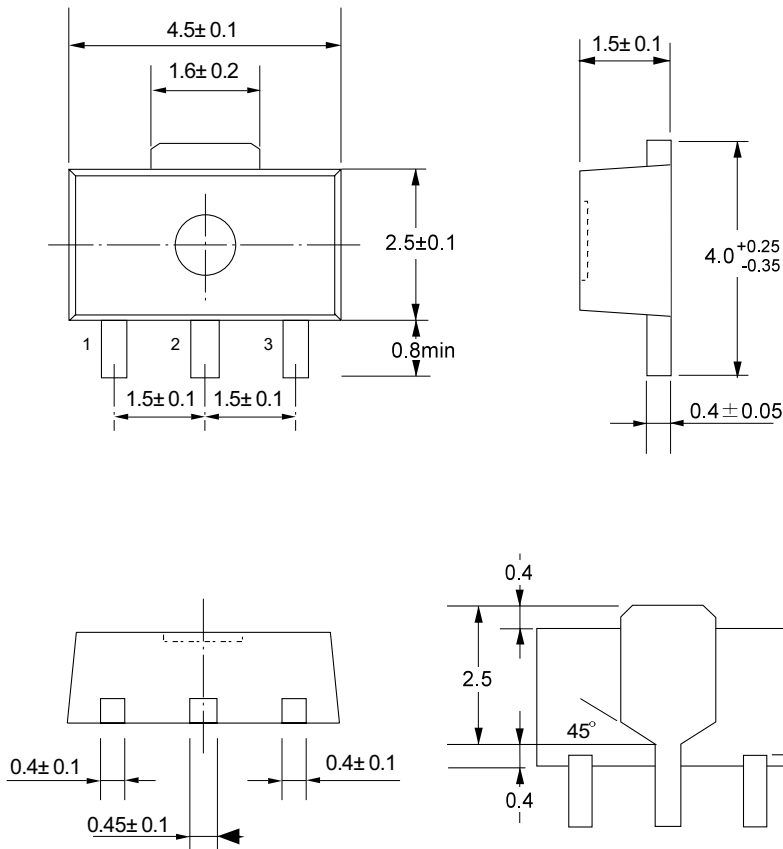

No. : UP003-A-P-SD-1.0

● Taping Specifications

● Reel Specifications

1 reel holds 1000 ICs.

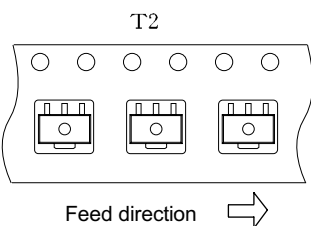
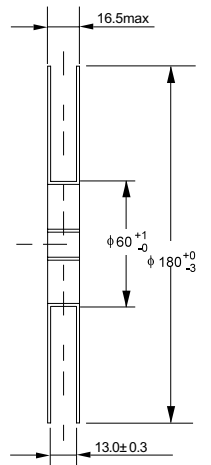
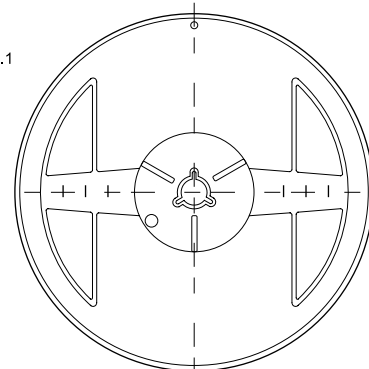
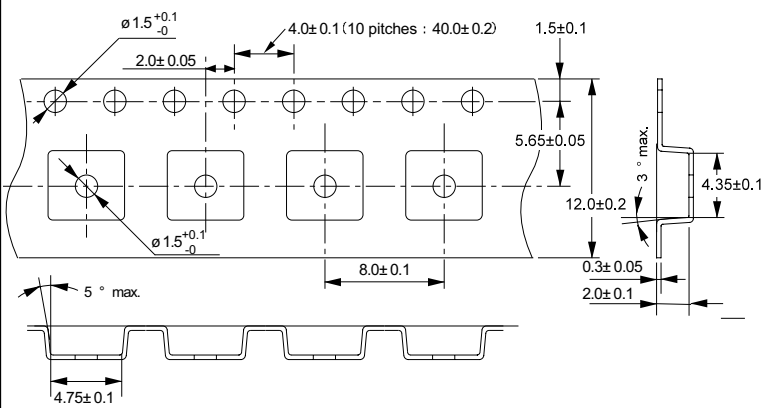

Winding core

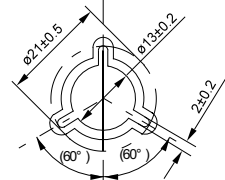

No. : UP003-A-C-SD-1.0

No. : UP003-A-R-SD-1.0

● SOT-23-5

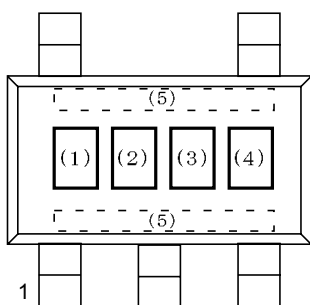

- (1) to (3) : Product name (abbreviation)
- (4) : Month of assembly
- (5) : Dot on one side
(Year and week of assembly)

No. : MP005-A-M-S1-1.0

● SOT-23-3

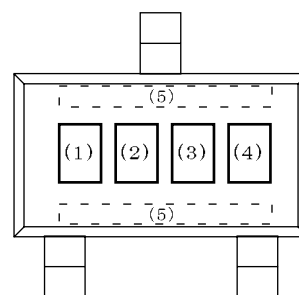

- (1) to (3) : Product name (abbreviation)
- (4) : Month of assembly
- (5) : Dot on one side
(Year and week of assembly)

No. : MP003-A-M-S1-1.0

● SOT-89-3

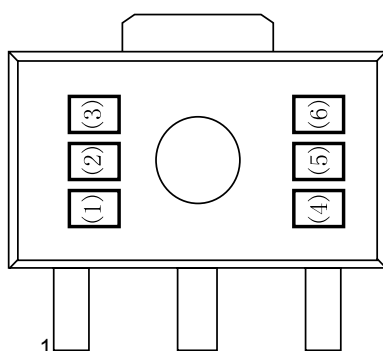

- (1) to (3) : Product name
(abbreviation)
- (4) : Year of assembly
- (5) : Month of assembly
- (6) : Week of assembly

No. : UP003-A-M-S1-1.0

- The information described herein is subject to change without notice.
- Seiko Instruments Inc. is not responsible for any problems caused by circuits or diagrams described herein whose related industrial properties, patents, or other rights belong to third parties. The application circuit examples explain typical applications of the products, and do not guarantee the success of any specific mass-production design.
- When the products described herein are regulated products subject to the Wassenaar Arrangement or other agreements, they may not be exported without authorization from the appropriate governmental authority.
- Use of the information described herein for other purposes and/or reproduction or copying without the express permission of Seiko Instruments Inc. is strictly prohibited.
- The products described herein cannot be used as part of any device or equipment affecting the human body, such as exercise equipment, medical equipment, security systems, gas equipment, or any apparatus installed in airplanes and other vehicles, without prior written permission of Seiko Instruments Inc.
- Although Seiko Instruments Inc. exerts the greatest possible effort to ensure high quality and reliability, the failure or malfunction of semiconductor products may occur. The user of these products should therefore give thorough consideration to safety design, including redundancy, fire-prevention measures, and malfunction prevention, to prevent any accidents, fires, or community damage that may ensue.