

BATTERY PROTECTION IC (FOR A 2-SERIAL-CELL PACK)**S-8232 SERIES**

The 8232 is a series of lithium-ion rechargeable battery protection ICs incorporating high-accuracy voltage detection circuits and delay circuits. It is suitable for a 2-serial-cell lithium-ion battery pack.

■ Features

- (1) Internal high-accuracy voltage detection circuit
 - Overcharge detection voltage 3.90 V \pm 25 mV to 4.60 V \pm 25 mV
5 mV- step
 - Overcharge release voltage 3.60 V \pm 50 mV to 4.60 V \pm 50 mV
5 mV- step

(The Overcharge release voltage can be selected within the range where a difference from Overcharge detection voltage is 0 to 0.3 V)
 - Overdischarge detection voltage 1.70 V \pm 80 mV to 2.60 V \pm 80 mV
50 mV- step
 - Overdischarge release voltage 1.70 V \pm 100 mV to 3.80 V \pm 100 mV
50 mV - step

(The Overdischarge release voltage can be selected within the range where a difference from Overdischarge detection voltage is 0 to 1.2V)
 - Overcurrent detection voltage 1 0.07 V \pm 20 mV to 0.30 V \pm 20 mV
5 mV-step
- (2) High input-voltage device (absolute maximum rating: 18 V)
- (3) Wide operating voltage range: 2.0 V to 16 V
- (4) The delay time for every detection can be set via an external capacitor.
Each delay time for Overcharge detection, Overdischarge detection, Overcurrent detection are "Proportion of hundred to ten to one."
- (5) Two overcurrent detection levels (protection for short-circuiting)
- (6) Internal auxiliary over voltage detection circuit (Fail safe for over voltage)
- (7) Internal charge circuit for 0V battery (Unavailable is option)
- (8) Low current consumption
 - Operation 7.5 μ A typ. 14.2 μ A max (-40 to +85 °C)
 - Power-down mode 0.2 nA typ. 0.1 μ A max (-40 to +85 °C)
- (9) TSSOP package (8-pin) 6.4 mm \times 3.1 mm

■ Applications

Lithium-ion rechargeable battery packs

■ Package Name

8-pinTSSOP (PKG code:FT008-A)

■ Selection Guide(05 .Sep ,2000)

Table1

Model/Item	Overcharge detection voltage _{1,2} (VCU _{1,2})	Overcharge release voltage _{1,2} (VCD _{1,2})	Overdischarge detection voltage _{1,2} (VDD _{1,2})	Overdischarge release voltage _{1,2} (VDU _{1,2})	Overcurrent detection voltage ₁ (VIOV ₁)	Overcharge detection delay time (t _{CU}) C ₃ =0.22μF	0V battery charging function
S-8232AAFT	4.25V±25mV	4.05±50mV	2.40V±80mV	3.00V±100mV	0.150V±20mV	1.0 sec	Available
S-8232ABFT	4.35V±25mV	4.15±50mV	2.30V±80mV	3.00V±100mV	0.300V±20mV	1.0 sec	Available
S-8232ACFT	4.35V±25mV	4.15±50mV	2.30V±80mV	3.00V±100mV	0.300V±20mV	1.0 sec	Unavailable
S-8232AEFT	4.35V±25mV	4.28±50mV	2.15V±80mV	2.80V±100mV	0.100V±20mV	1.0 sec	Available
S-8232AFFT	4.25V±25mV	4.05±50mV	2.30V±80mV	2.70V±100mV	0.300V±20mV	1.0 sec	Available
S-8232AGFT	4.25V±25mV	4.05±50mV	2.20V±80mV	2.40V±100mV	0.200V±20mV	1.0 sec	Available
S-8232AHFT	4.25V±25mV	4.05±50mV	2.20V±80mV	2.40V±100mV	0.300V±20mV	1.0 sec	Available
S-8232AIFT	4.325V±25mV	4.325V *1,2	2.40V±80mV	3.00V±100mV	0.300V±20mV	1.0 sec	Unavailable
S-8232AJFT	4.25V±25mV	4.05±50mV	2.40V±80mV	3.00V±100mV	0.150V±20mV	1.0 sec	Unavailable
S-8232AKFT	4.20V±25mV	4.00±50mV	2.30V±80mV	2.90V±100mV	0.200V±20mV	1.0 sec	Available
S-8232ALFT	4.30V±25mV	4.05±50mV	2.00V±80mV	3.00V±100mV	0.200V±20mV	1.0 sec	Available
S-8232AMFT	4.19V±25mV	4.19 V *1	2.00V±80mV	3.00V±100mV	0.190V±20mV	1.0 sec	Available
S-8232ANFT	4.325V±25mV	4.325V *1,3	2.40V±80mV	3.00V±100mV	0.300V±20mV	1.0 sec	Unavailable
S-8232AOFT	4.30V±25mV	4.05±50mV	2.00V±80mV	3.00V±100mV	0.230V±20mV	1.0 sec	Available
S-8232APFT	4.28V±25mV	4.05±50mV	2.30V±80mV	2.90V±100mV	0.100V±20mV	1.0 sec	Unavailable
S-8232ARFT	4.325V±25mV	4.325V *1,3	2.00V±80mV	2.50V±100mV	0.300V±20mV	1.0 sec	Unavailable
S-8232ASFT *4	4.295V±25mV	4.20±50mV *3	2.30V±80mV	3.00V±100mV	0.300V±20mV	1.0 sec	Unavailable
S-8232ATFT	4.125V±25mV	4.125±50mV *1	2.00V±80mV	3.00V±100mV	0.190V±20mV	1.0 sec	Available
S-8232AUFT	4.30V±25mV	4.10±50mV	2.40V±80mV	3.00V±100mV	0.200V±20mV	1.0 sec	Unavailable
S-8232AVFT	4.30V±25mV	4.05V±50mV	2.00V±80mV	3.00V±100mV	0.300V±20mV	1.0 sec	Available
S-8232AWFT	4.35V±25mV	4.15V±50mV	2.30V±80mV	3.00V±100mV	0.150V±20mV	1.0 sec	Unavailable
S-8232AXFT	4.325V±25mV	4.200V±50mV	2.30V±80mV	3.00V±100mV	0.20V±20mV	1.0 sec	Unavailable
S-8232AYFT	4.30V±25mV	4.05V±50mV	2.00V±80mV	2.00V±100mV	0.20V±20mV	1.0 sec	Available

- *1: No overcharge detection/release hysteresis
- *2: The magnification of final overcharge is 1.11; other is 1.25.
- *3: No final overcharging function
- *4: Refer to the Description of Operation (*3).

Change in the detection voltage is available in products other than the above listed ones.
 Please contact with our sales division.

The overdischarge detection voltage can be selected within the range from 1.7 to 3.0V.
 When the Overdischarge detection voltage is higher than 2.6V, the Overcharge detection voltage and the Overcharge release voltage are limited as table 2.

Table 2

Overdischarge detection voltage _{1,2} (VDD _{1,2})	Overcharge detection voltage _{1,2} (VCU _{1,2})	Voltage difference between Overcharge detection voltage and Overcharge release voltage (VCU _{1,2} - VCD _{1,2})
1.70 to 2.60 V	3.90 to 4.60 V	0 to 0.30 V
1.70 to 2.80 V	3.90 to 4.60 V	0 to 0.20 V
1.70 to 3.00 V	3.90 to 4.50 V	0 to 0.10 V

■ Block Diagram

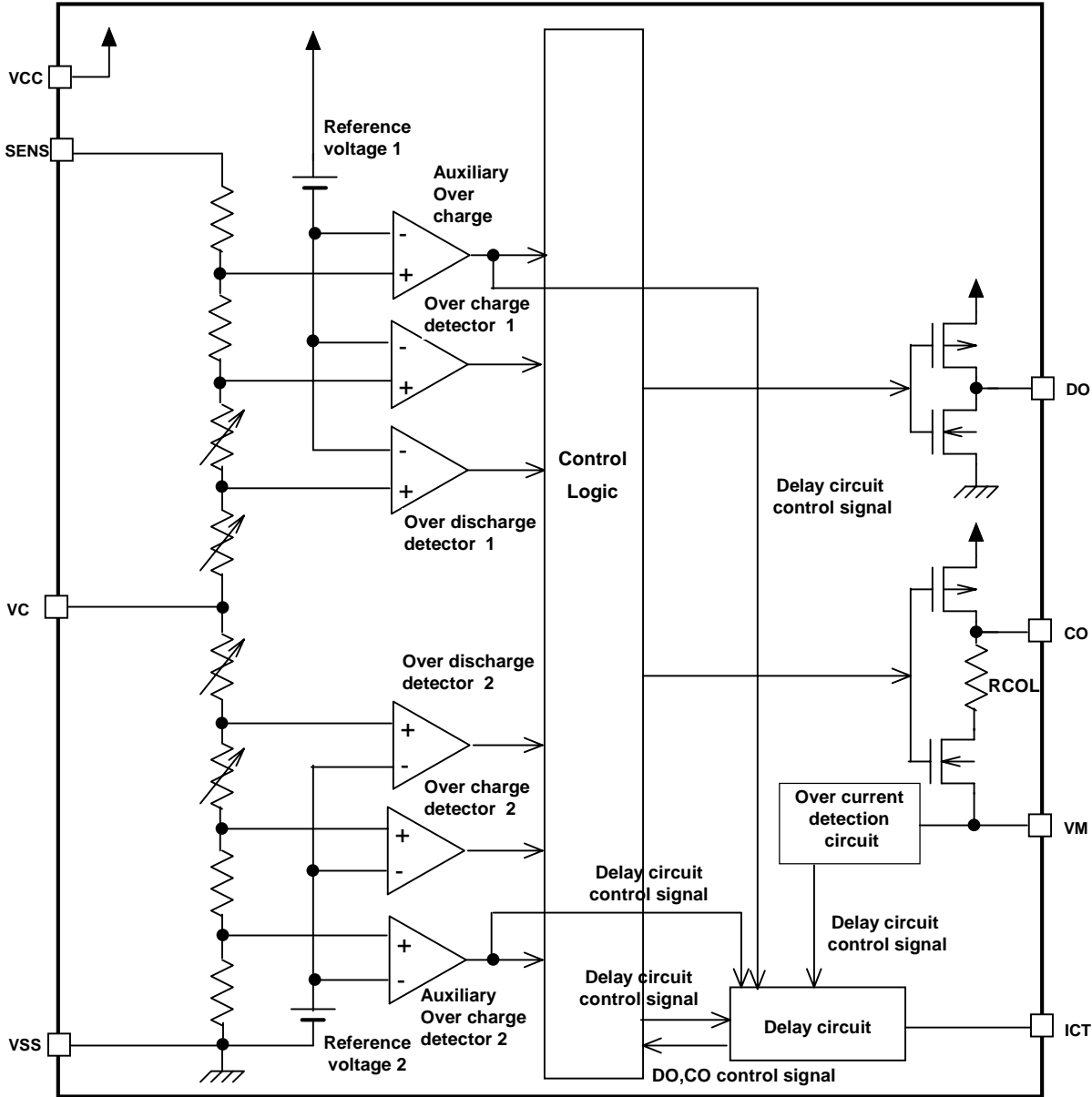
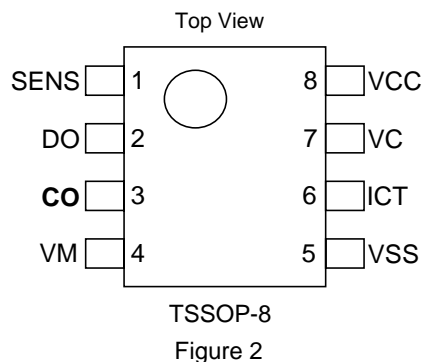

Figure 1

Output impedance when CO terminal output 'L' is higher than DO terminal. RCOL resistor is connected with CO terminal. Please refer 'Electric Characteristics'.

■ Pin Assignment



■ Pin Description

Table 3

No.	Name	Description
1	SENS	Detects pin for VCC voltage (Connects battery1 positive voltage)
2	DO	Connects FET gate for discharge control (CMOS output)
3	CO	Connects FET gate for charge control (CMOS output)
4	VM	Detects pin for VM voltage (Overcurrent detection pin)
5	VSS	Negative power input pin (Connects battery2 negative voltage)
6	ICT	Connects capacitor for delay circuit
7	VC	The middle pin between two batteries (Connects battery1 negative voltage and battery2 positive voltage)
8	VCC	Positive power input pin (Connects battery1 positive voltage)

■ Absolute Maximum Ratings

Table 4

Ta = 25°C

Item	Symbol	Applied Pins	Rating	Unit
Input voltage between VCC and VSS	VDS	VCC	VSS-0.3 to VCC+18	V
SENS Input terminal voltage	VSSENS	SENS	VSS-0.3 to VCC+0.3	V
ICT Input terminal voltage	VICT	ICT	VSS-0.3 to VCC+0.3	V
VM Input terminal voltage	VVM	VM	VCC-18 to VCC+0.3	V
DO output terminal voltage	VDO	DO	VSS-0.3 to VCC+0.3	V
CO output terminal voltage	VCO	CO	VVM-0.3 to VCC+0.3	V
Power dissipation	PD		300	mW
Operating temperature range	Topr		-40 to +85	°C
Storage temperature range	Tstg		-40 to +125	°C

■ Electrical Characteristics

Table 5

Ta = 25°C

	Symbol	Condition	Circuit	Notice	Min.	Typ.	Max.	Unit
Detection voltage								
Overcharge detection voltage 1,2	V _{CU1,2}	1,2	1	3.90 to 4.60 Adjustment	V _{CU1,2} -0.025	V _{CU1,2}	V _{CU1,2} +0.025	V
Auxiliary overcharge detection voltage 1,2 V _{CUaux1,2} = V _{CU1,2} × 1.25 or V _{CUaux1,2} = V _{CU1,2} × 1.11	V _{CUaux1,2}	1,2	1	V _{CU1,2} × 1.25 Fixed Type	V _{CU1,2} × 1.21	V _{CU1,2} × 1.25	V _{CU1,2} × 1.29	V
	V _{CUaux1,2}	1,2	1	V _{CU1,2} × 1.11 Fixed Type	V _{CU1,2} × 1.07	V _{CU1,2} × 1.11	V _{CU1,2} × 1.15	V
Overcharge release voltage 1,2	V _{CD1,2}	1,2	1	3.60 to 4.60 Adjustment	V _{CD1,2} -0.050	V _{CD1,2}	V _{CD1,2} +0.050	V
Overdischarge detection voltage 1,2	V _{DD1,2}	1,2	1	1.70 to 2.60 Adjustment	V _{DD1,2} -0.080	V _{DD1,2}	V _{DD1,2} +0.080	V
Overdischarge release voltage 1,2	V _{DU1,2}	1,2	1	1.70 to 3.80 Adjustment	V _{DU1,2} -0.100	V _{DU1,2}	V _{DU1,2} +0.100	V
Overcurrent detection voltage 1	V _{IOV1}	3	1	0.07 to 0.30 Adjustment	V _{IOV1} -0.020	V _{IOV1}	V _{IOV1} +0.020	V
Overcurrent detection voltage 2	V _{IOV2}	3	1	V _{CC} Reference	-1.57	-1.20	-0.83	V
Voltage temperature factor 1	T _{COE1}			(*1) Ta=-40 to 85°C	-0.6	0	0.6	mV/°C
Voltage temperature factor 2	T _{COE2}			(*2) Ta=-40 to 85°C	-0.24	-0.05	0	mV/°C
Delay time(C3=0.22μF)								
Overcharge detection delay time1,2	t _{CU1,2}	8,9	5	1.0 S	0.73	1.00	1.35	S
Overdischarge detection delay time 1,2	t _{DD1,2}	8,9	5	0.1 S	68	100	138	mS
Overcurrent detection delay time1	t _{IOV1}	10	5	0.01 S	6.7	10	13.9	mS
Input voltage								
Input voltage between V _{CC} and V _{SS}				absolute maximum rating	-0.3	---	18	
Operating voltage								
Operating voltage between V _{CC} and V _{SS}	V _{D_{SOP}}			(*3)	2.0	---	16	V
Current consumption								
Current consumption during normal operation	I _{OPE}	4	2	V ₁ =V ₂ =3.6V	2.1	7.5	12.7	μA
Current consumption at power down	I _{PDN}	4	2	V ₁ =V ₂ =1.5V	0	0.0002	0.04	μA
Output voltage								
DO ^H voltage	V _{DO(H)}	6	3	at I _{out} =10uA	V _{CC} -0.05	V _{CC} -0.003	---	V
DO ^L voltage	V _{DO(L)}	6	3	at I _{out} =10uA	---	V _{SS} +0.003	V _{SS} +0.05	V
CO ^H voltage	V _{CO(H)}	7	4	at I _{out} =10uA	V _{CC} -0.15	V _{CC} -0.019	---	V
CO pin internal resistance								
Resistance between V _{SS} and CO	R _{COL}	7	4	V _{SS} -CO=4.7V×2	0.29	0.6	1.44	MΩ
Internal resistance								
Resistance between V _{CC} and VM	R _{vcm}	5	2	V _{CC} -VM=0.5V	105	240	575	KΩ
Resistance between V _{SS} and VM	R _{vsm}	5	2	VM-V _{SS} =1.1V	511	597	977	KΩ
0V battery charging function								
0V charge starting voltage	V _{OCHA}	11	6	0V batt. Cha. Available	0.38	0.75	1.12	V
0V charge inhibiting voltage 1,2	V _{OINH1,2}	12,13	6	0V batt. Cha. Unavailable	0.32	0.88	1.44	V

(*1)Voltage temperature factor 1 indicates overcharge detection voltage, overcharge release voltage, overdischarge detection voltage, and overdischarge release voltage.

(*2)Voltage temperature factor 2 indicates overcurrent detection voltage.

(*3)The DO and CO logic must be established for the operating voltage.

Table 6 Ta = -40 to +85°C

	Symbol	Condition	Circuit	Notice	Min.	Typ.	Max.	Unit
Detection voltage								
Overcharge detection voltage 1,2	VCU1,2	1,2	1	3.90 to 4.60 Adjustment	VCU1,2 -0.055	VCU1,2	VCU1,2 +0.045	V
Auxiliary overcharge detection voltage 1,2 VCUaux1,2 = VCU1,2x1.25 or VCUaux1,2 = VCU1,2x1.11	VCUaux1,2	1,2	1	VCU1,2x1.25 Fixed. Type	VCU1,2 x1.19	VCU1,2 x1.25	VCU1,2 x1.31	V
	VCUaux1,2	1,2	1	VCU1,2x1.11 Fixed. Type	VCU1,2 x1.05	VCU1,2 x1.11	VCU1,2 x1.17	V
Overcharge release voltage 1,2	VCD1,2	1,2	1	3.60 to 4.60 Adjustment	VCD1,2 -0.080	VCD1,2	VCD1,2 +0.070	V
Overdischarge detection voltage 1,2	VDD1,2	1,2	1	1.70 to 2.60 Adjustment	VDD1,2 -0.110	VDD1,2	VDD1,2 +0.100	V
Overdischarge release voltage 1,2	VDU1,2	1,2	1	1.70 to 3.80 Adjustment	VDU1,2 -0.130	VDU1,2	VDU1,2 +0.120	V
Overcurrent detection voltage 1	VIOV1	3	1	0.07 to 0.30 Adjustment	VIOV1-0.033	VIOV1	VIOV1+0.0 33	V
Overcurrent detection voltage 2	VIOV2	3	1	VCC Reference	-1.70	-1.20	-0.71	V
Voltage temperature factor 1	TCOE1			(*1) Ta=-40 to 85°C	-0.6	0	0.6	mV/°C
Voltage temperature factor 2	TCOE2			(*2) Ta=-40 to 85°C	-0.24	-0.05	0	mV/°C
Delay time(C3=0.22μF)								
Overcharge detection delay time1,2	tCU1,2	8,9	5	1.0 S	0.55	1.00	2.06	S
Overdischarge detection delay time 1,2	tDD1,2	8,9	5	0.1 S	67	100	141	mS
Overcurrent detection delay time1	tIOV1	10	5	0.01 S	6.3	10	14.7	mS
Input voltage								
Input voltage between VCC and VSS				absolute maximum rating	-0.3	---	18	
Operating voltage								
Operating voltage between VCC and VSS	VDSOP			(*3)	2.0	---	16	V
Current consumption								
Current consumption during normal operation	IOPE	4	2	V1=V2=3.6V	1.8	7.5	14.2	μA
Current consumption at power down	IPDN	4	2	V1=V2=1.5V	0	0.0002	0.10	μA
Output voltage								
DO"H"voltage	VDO(H)	6	3	at Iout=10uA	VCC-0.17	VCC-0.003	---	V
DO"L"voltage	VDO(L)	6	3	at Iout=10uA	---	VSS+0.003	VSS+0.17	V
CO"H"voltage	VCO(H)	7	4	at Iout=10uA	VCC-0.27	VCC-0.019	---	V
CO pin internal resistance								
Resistance between VSS and CO	RCOL	7	4	VSS-CO=4.7Vx2	0.22	0.6	2.20	MΩ
Internal resistance								
Resistance between VCC and VM	Rvcm	5	2	Vcc-VM=0.5V	79	240	878	KΩ
Resistance between VSS and VM	Rvsm	5	2	VM-VSS=1.1V	387	597	1491	KΩ
0V battery charging function								
0V charge starting voltage	VOCHA	11	6	0V batt. Cha. Available	0.26	0.75	1.25	V
0V charge inhibiting voltage 1,2	VOINH1,2	12,13	6	0V batt. Cha. Unavailable	0.20	0.88	1.57	V

(*1)Voltage temperature factor 1 indicates overcharge detection voltage, overcharge release voltage, overdischarge detection voltage, and overdischarge release voltage.

(*2)Voltage temperature factor 2 indicates overcurrent detection voltage.

(*3)The DO and CO logic must be established for the operating voltage.

■ Measurement Circuits

(1) Measurement 1 Measurement circuit 1

Set S1=OFF, V1=V2=3.6 V, and V3=0V under normal condition. Increase V1 from 3.6 V gradually.
The V1 voltage when CO = 'L' is overcharge detection voltage 1 (VCU1). Decrease V1 gradually.
The V1 voltage when CO = 'H' is overcharge release voltage 1 (VCD1). Further decrease V1.
The V1 voltage when DO = 'L' is overdischarge voltage 1 (VDD1). Increase V1 gradually.
The V1 voltage when DO = 'H' is overdischarge release voltage 1 (VDU1).
Set S1=ON, and V1=V2=3.6 V and V3=0V under normal condition. Increase V1 from 3.6 V gradually.
The V1 voltage when CO = 'L' is auxiliary overcharge detection voltage 1 (VCUaux1).

(2) Measurement 2 Measurement circuit 1

Set S1=OFF, V1=V2=3.6 V, and V3=0V under normal condition. Increase V2 from 3.6 V gradually.
The V2 voltage when CO = 'L' is overcharge detection voltage 2 (VCU2). Decrease V2 gradually.
The V2 voltage when CO = 'H' is overcharge release voltage 2 (VCD2). Further decrease V2.
The V2 voltage when DO = 'L' is overdischarge voltage 2 (VDD2). Increase V2 gradually.
The V2 voltage when DO = 'H' is overdischarge release voltage 2 (VDU2).
Set S1=ON, and V1=V2=3.6 V and V3=0V under normal condition. Increase V2 from 3.6 V gradually.
The V2 voltage when CO = 'L' is auxiliary overcharge detection voltage 2 (VCUaux2).

(3) Measurement 3 Measurement circuit 1

Set S1=OFF, V1=V2=3.6 V, and V3=0V under normal condition. Increase V3 from 0V gradually.
The V3 voltage when DO = 'L' is overcurrent detection voltage 1 (VIOV1).
Set S1=ON, V1=V2=3.6 V, V3=0 under normal condition. Increase V3 from 0V gradually. (The voltage change rate < 1.0V/msec) (V1+V2-V3) voltage when DO = 'L' is overcurrent detection voltage 2 (VIOV2).

(4) Measurement 4 Measurement circuit 2

Set S1=ON, V1=V2=3.6 V, and V3=0 V under normal condition and measure current consumption.
Current consumption I1 is the normal condition current consumption (IOPE).
Set S1=OFF, V1=V2=1.5 V under overdischarge condition and measure current consumption.
Current consumption I1 is the power-down current consumption (IPDN).

(5) Measurement 5 Measurement circuit 2

Set S1=ON, V1=V2=V3=1.5 V, and V3=2.5V under overdischarge condition. (V1+V2-V3)/I2 is the internal resistance between VCC and VM (Rvcm).
Set S1=ON, V1=V2=3.5V, and V3=1.1 V under overcurrent condition. V3/I2 is the internal resistance between VSS and VM (Rvsm).

(6) Measurement 6 Measurement circuit 3

Set S1=ON, S2=OFF, V1=V2=3.6 V, and V3=0V under normal condition. Increase V4 from 0 V gradually. The V4 voltage when I1 = 10 μ A is DO'H' voltage (VD0 (H)).

Set S1=OFF, S2=ON, V1=V2=3.6 V, and V3=0.5 V under overcurrent condition. Increase V5 from 0 V gradually. The V5 voltage when I2 = 10 μ A is the DO'L' voltage (VDO (L)).

(7) Measurement 7 Measurement circuit 4

Set S1=ON, S2=OFF, V1=V2=3.6 V and V3=0 V under normal condition. Increase V4 from 0 V gradually. The V4 voltage when I1 = 10 μ A is the CO'H' voltage (VC0 (H)).

Set S1=OFF S2=ON, V1=V2=4.7, V3=0V, and V4=9.4V under over voltage condition. (V5)/I2 is the CO pin internal resistance (RCOL).

(8) Measurement 8 Measurement circuit 5

Set V1=V2=3.6 V, and V3=0V under normal condition. Increase V1 from (VCU1-0.2V) to (VCU1+0.2V) immediately (within 10 μ s). The time after V1 becomes (VCU1+0.2V) until CO goes 'L' is the overcharge detection delay time 1 (tCU1).

Set V1=V2=3.5 V, and V3=0V under normal condition. Decrease V1 from (VDD1+0.2V) to (VDD1-0.2V) immediately (within 10 μ s). The time after V1 becomes (VDD1-0.2V) until DO goes 'L' is the overdischarge detection delay time 1 (tDD1).

(9) Measurement 9 Measurement circuit 5

Set V1=V2=3.6 V, and V3=0V under normal condition. Increase V2 from (VCU2-0.2V) to (VCU2+0.2V) immediately (within 10 μ s). The time after V2 becomes (VCU2+0.2V) until CO goes 'L' is the overcharge detection delay time 2 (tCU2).

Set V1=V2=3.6 V, and V3=0V under normal condition. Decrease V2 from (VDD2+0.2V) to (VDD2-0.2V) immediately (within 10 μ s). The time after V2 becomes (VDD2-0.2V) until DO goes 'L' is the overdischarge detection delay time 2 (tDD2).

(10) Measurement 10 Measurement circuit 5

Set V1=V2=3.6 V, and V3=0V under normal condition. Increase V3 from 0 V to 0.5 V immediately (within 10 μ s). The time after V3 becomes 0.5 V until DO goes 'L' is the overcurrent detection delay time 1 (tI0V1).

(11) Measurement 11 Measurement circuit 6

Set V1=V2=0 V, and V3=2 V, and decrease V3 gradually. The V3 voltage when CO = 'L' (VCC- 0.3 V or lower) is the 0V charge starting voltage (V0CHA).

(12) Measurement 12 Measurement circuit 6

Set V1=0 V, V2=3.6 V, and V3=12 V, and increase V1 gradually. The V1 voltage when CO = 'H' (VM+ 0.3 V or higher) is the 0V charge inhibiting voltage 1 (V0INH1).

(13) Measurement 13 Measurement circuit 6

Set V1=3.6 V, V2=0 V, and V3=12 V, and increase V2 gradually. The V2 voltage when CO = 'H' (VM+ 0.3 V or higher) is the 0V charge inhibiting voltage 2 (V0INH2).

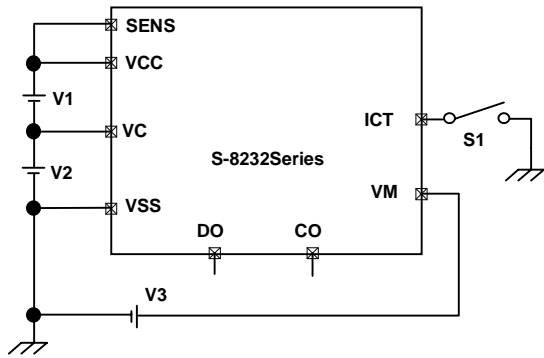

Measurement circuit 1

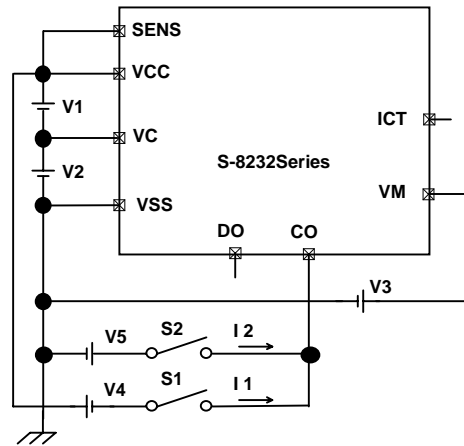

Measurement circuit 4

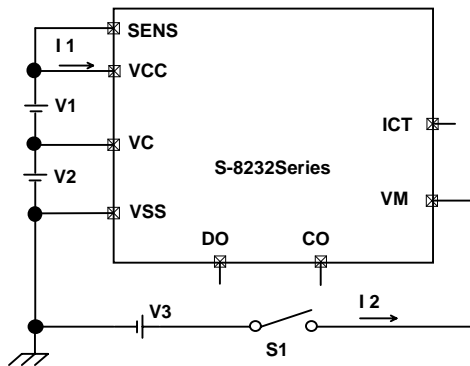

Measurement circuit 2

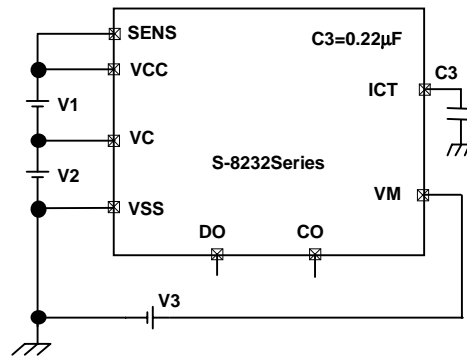

Measurement circuit 5

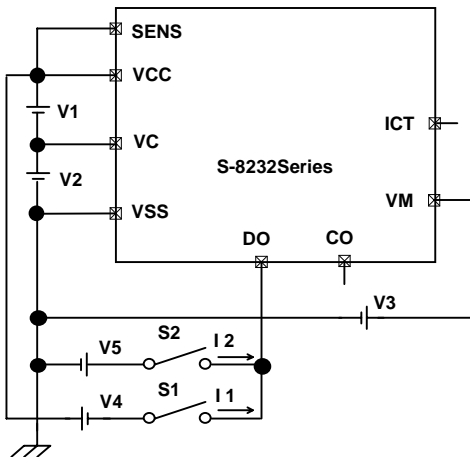

Measurement circuit 3

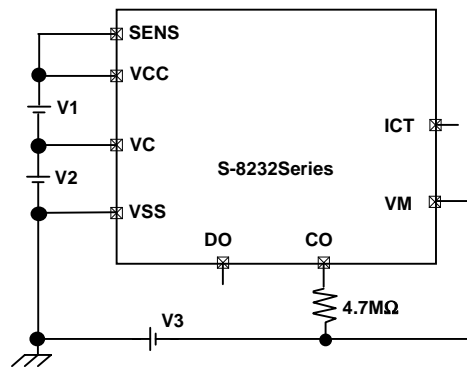

Measurement circuit 6

■ Description

Normal condition(*1, 3)

This IC monitors the voltages of the two serially-connected batteries and the discharge current to control charging and discharging. If the voltages of all the two batteries are in the range from the overdischarge detection voltage (VDD1,2) to the overcharge detection voltage (VCU1,2), and the current flowing through the batteries becomes equal or lower than a specified value (the VM terminal voltage is equal or lower than overcurrent detection voltage 1), the charging and discharging FET's turn on. In this condition, charging and discharging can be carried out freely. This condition is called the normal condition. In this condition, the VM and VSS terminals are shorted by the Rvsm resistor.

Overcurrent condition

This IC is provided with the two overcurrent detection levels (VIOV1 and VIOV2) and the two overcurrent detection delay time (tIOV1 and tIOV2) corresponding to each overcurrent detection level.

If the discharging current becomes equal to or higher than a specified value (the VM terminal voltage is equal to or higher than the overcurrent detection voltage) during discharging under normal condition and it continues for the overcurrent detection delay time (tIOV) or longer, the discharging FET turns off to stop discharging. This condition is called an overcurrent condition. The VM and VSS terminals are shorted by the Rvsm resistor at this time. The charging FET turns off.

When the discharging FET is off and a load is connected, the VM terminal voltage equals the VCC potential.

The overcurrent condition returns to the normal condition when the load is released and the impedance between the EB- and EB+ terminals (see Figure 6 for a connection example) is 200MΩ or higher.

When the load is released, the VM terminal, which and the VSS terminal are shorted with the Rvsm resistor, goes back to the VSS potential. The IC detects that the VM terminal potential returns to overcurrent detection voltage 1 (VIOV1) or lower and returns to the normal condition.

Overcharge condition

The overcharge condition is detected in two cases:

- 1) If one of the battery voltages becomes higher than the overcharge detection voltage (VCU1,2) during charging under normal condition and it continues for the overcharge detection delay time (tCU1,2) or longer, the charging FET turns off to stop charging.
- 2) If one of the battery voltages becomes higher than the auxiliary overcharge detection voltage (VCUaux1,2) the charging FET turns off immediately to stop charging.

The VM and VSS terminals are shorted by the Rvsm resistor under the overcharge condition.

The auxiliary overcharge detection voltage (VCUaux1,2) is fixed internally and calculated by the overcharge detection voltage (VCU1,2) as follows:

$$VCUaux1,2 [V] = 1.25 \times VCU1,2 [V]$$

[For without Overcharge detection / release hysteresis type (VCU1,2 = VCD1,2)]

$$VCUaux1,2 [V] = 1.11 \times VCU1,2 [V]$$

The overcharge condition is released in two cases:

- 1) The battery voltage which exceeded the overcharge detection voltage (VCU1,2) falls below the overcharge release voltage (VCD1,2), the charging FET turns on and the normal condition returns.
- 2) If the battery voltage which exceeded the overcharge detection voltage (VCU1,2) is equal or higher than the overcharge release voltage (VCD1,2), but the charger is removed, a load is placed, and discharging starts, the charging FET turns on and the normal condition returns.

The release mechanism is as follows: the discharge current flows through an internal parasitic diode of the charging FET immediately after a load is installed and discharging starts, and the VM terminal voltage decreases by about 0.6 V from the VSS terminal voltage momentarily. The IC detects this voltage (overcurrent detection voltage 1 or higher), releases the overcharge condition and returns to the normal condition.

Overdischarge condition

If any one of the battery voltages falls below the overdischarge detection voltage (VDD1,2) during discharging under normal condition and it continues for the overdischarge detection delay time (tDD1,2) or longer, the discharging FET turns off and discharging stops. This condition is called the overdischarge condition. When the discharging FET turns off, the VM terminal voltage becomes equal to the VCC voltage and the IC's current consumption falls below the power-down current consumption (IPDN). This condition is called the power-down condition. The VM and VCC terminals are shorted by the Rvcm resistor under the overdischarge and power-down conditions.

The power-down condition is canceled when the charger is connected and the voltage between VM and VCC is overcurrent detection voltage 2 or higher. When all the battery voltages becomes equal to or higher than the overdischarge release voltage (VDU1,2) in this condition, the overdischarge condition changes to the normal condition.

Delay circuits

The overcharge detection delay time (tCU1,2), overdischarge detection delay time (tDD1,2), and overcurrent detection delay time 1 (tIOV1) are changed with external capacitor (C3). The delay time for overcharge and overdischarge and overcurrent detection is changed via an external capacitor. Those three detection delay times are consistent with each other, describe as below.

Overcharge delay time : Overdischarge delay time: Overcurrent delay time = 100 : 10 : 1

The delay times are calculated by the following equations: (Ta=-40 to +85°C)

Overcharge detection delay time	Min	Typ.	Max.
tCU[S] =Delay factor (2.500,	4.545,	9.364)×C3 [uF]
Overdischarge detection delay time			
tDD[S] =Delay factor (0.3045,	0.4545,	0.6409)×C3 [uF]
Overcurrent detection delay time			
tIOV1[S]=Delay factor (0.02864,	0.04545,	0.06682)×C3 [uF]

Note: The delay time for overcurrent detection 2 is fixed by an internal IC circuit. The delay time cannot be changed via an external capacitor.

0V battery charging function (*2)

This function is used to recharge both of two serially-connected batteries after they self-discharge to 0V. When the 0V charging start voltage (V0CHA) or higher is applied to between VM and VCC by connecting the charger, the charging FET gate is fixed to VCC potential.

When the voltage between the gate sources of the charging FET becomes equal to or higher than the turn-on voltage by the charger voltage, the charging FET turns on to start charging. At this time, the discharging FET turns off and the charging current flows through the internal parasitic diode in the discharging FET. If all the battery voltages become equal to or higher than the overdischarge release voltage (VDU1,2), the normal condition returns.

0 V battery charge inhibiting function (*2)

This function is used for inhibiting charging when either of the connected batteries goes 0 V due to its self-discharge. When the voltage of either of the connected batteries goes below 0 V charge inhibit voltage 1 and 2 (VOINH1, 2), the charging FET gate is fixed to "EB -" to inhibit charging. Charging is possible only when the voltage of both connected batteries goes 0 V charge inhibit voltage 1 and 2 (VOINH1, 2) or more.

Note that charging may be possible when the total voltage of both connected batteries is less than the minimum value (VDSOP min) of the operating voltage between VCC-VSS even if the voltage of either of the connected batteries is 0 V charge inhibit voltage 1 and 2 (VOINH1, 2) or less. Charging is prohibited when the total voltage of both connected batteries reaches the minimum value (VDSOPmin) of the operating voltage between VCC-VSS.

When using this optional function, a resistor of 4.7 MΩ is needed between the gate and the source of the charging control FET (refer to Figure 6).

(*1)

When initially connecting batteries, the IC may fail to enter the normal condition (discharging ready state). If so, once set the VM pin to VSS voltage (short pins VM and VSS or connect a charger).

(*2)

Some lithium ion batteries are not recommended to be recharged after having been completely discharged. Please contact the battery manufacturer when you decide to select a 0 V battery charging function.

(*3)

The products indicated with *4 in the Selection Guide (model name/item) are set to "overcharge detection/release hysteresis," "no final overcharge function," and "0 V battery charge inhibiting function." The following phenomena may be found, but there is no problem for practical use. The product is an overcurrent condition due to overload connection when the battery voltage is overcharge release voltage (VCD1, 2) or more and overcharge detection voltage (VCU1, 2) or less. Usually, the IC returns to its normal condition when overload is removed under this condition. However, the charging FET may be turned OFF when overload is removed under this condition, leading to an overcharge condition. If so, attach load to start discharge. The charging FET is turned ON to return to the normal condition. Refer to "OverCharge Condition" of Description Section.

■ Operation Timing Charts

1. Overcharge detection

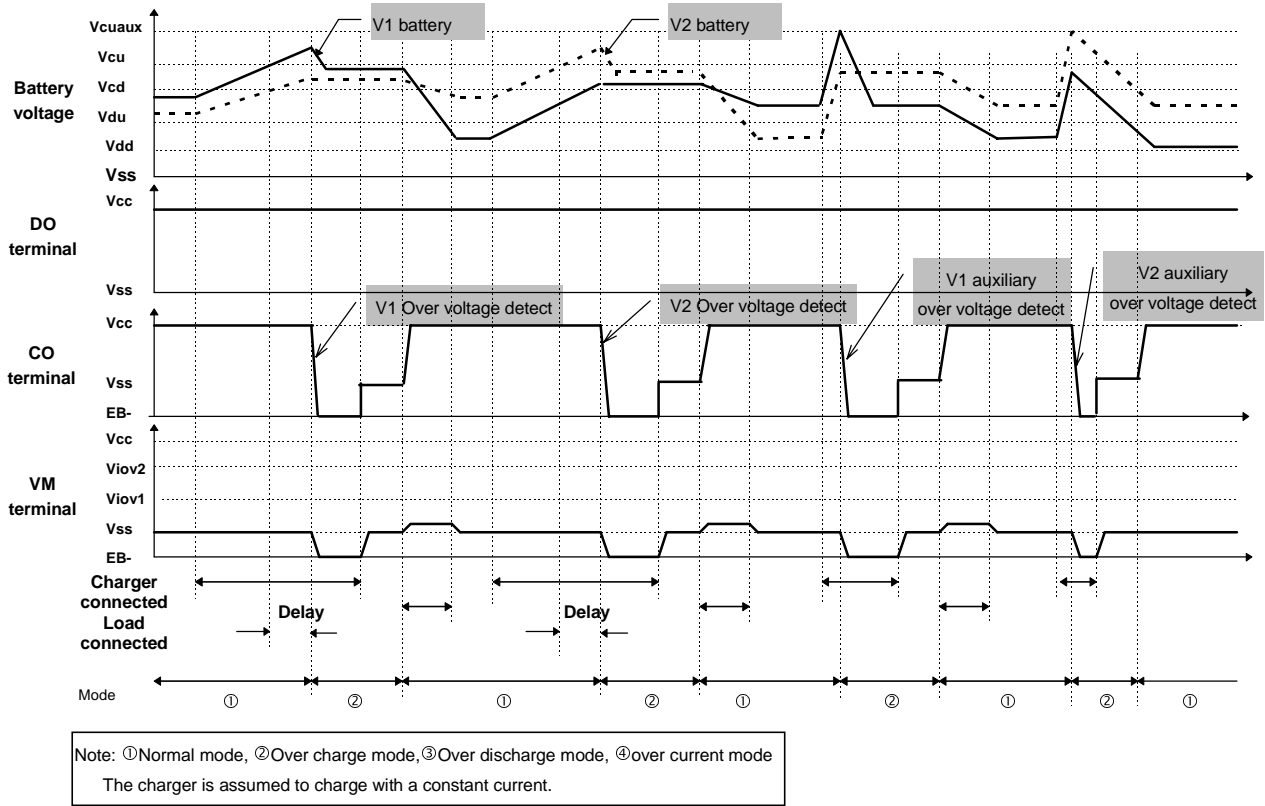

Figure 3

2. Overdischarge detection

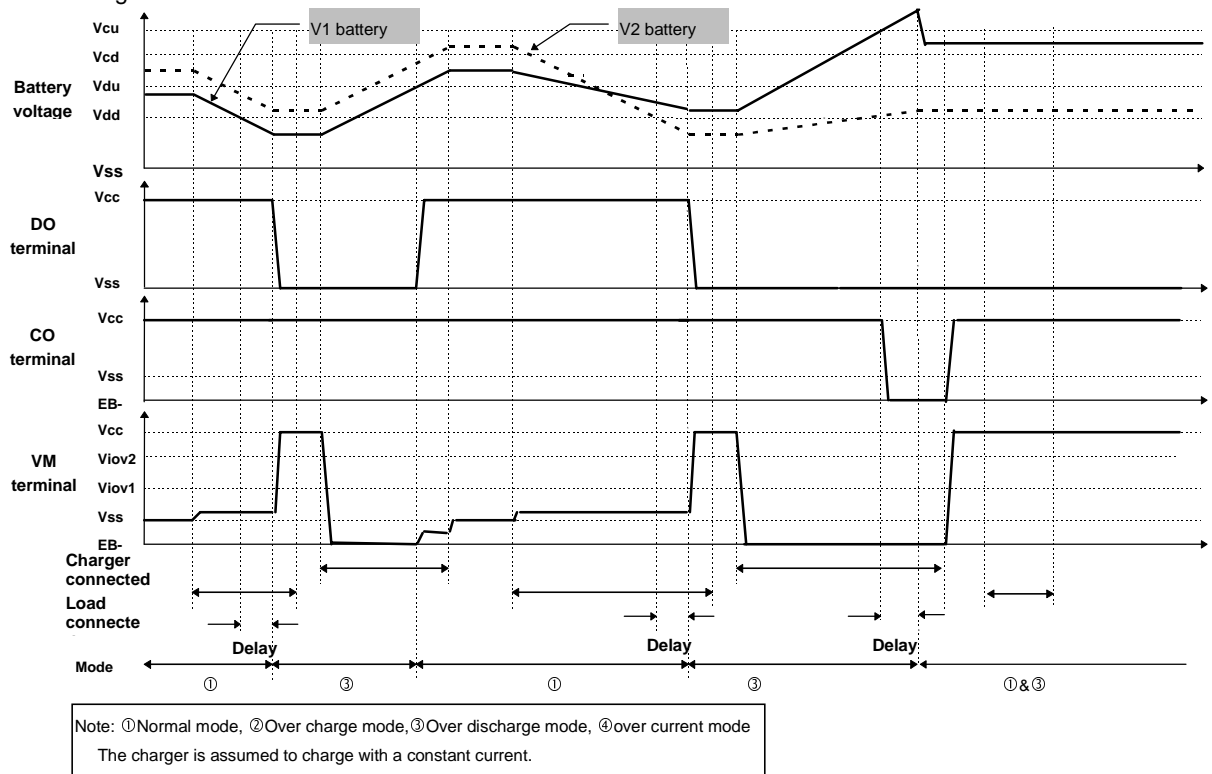

Figure 4

3. Overcurrent detection

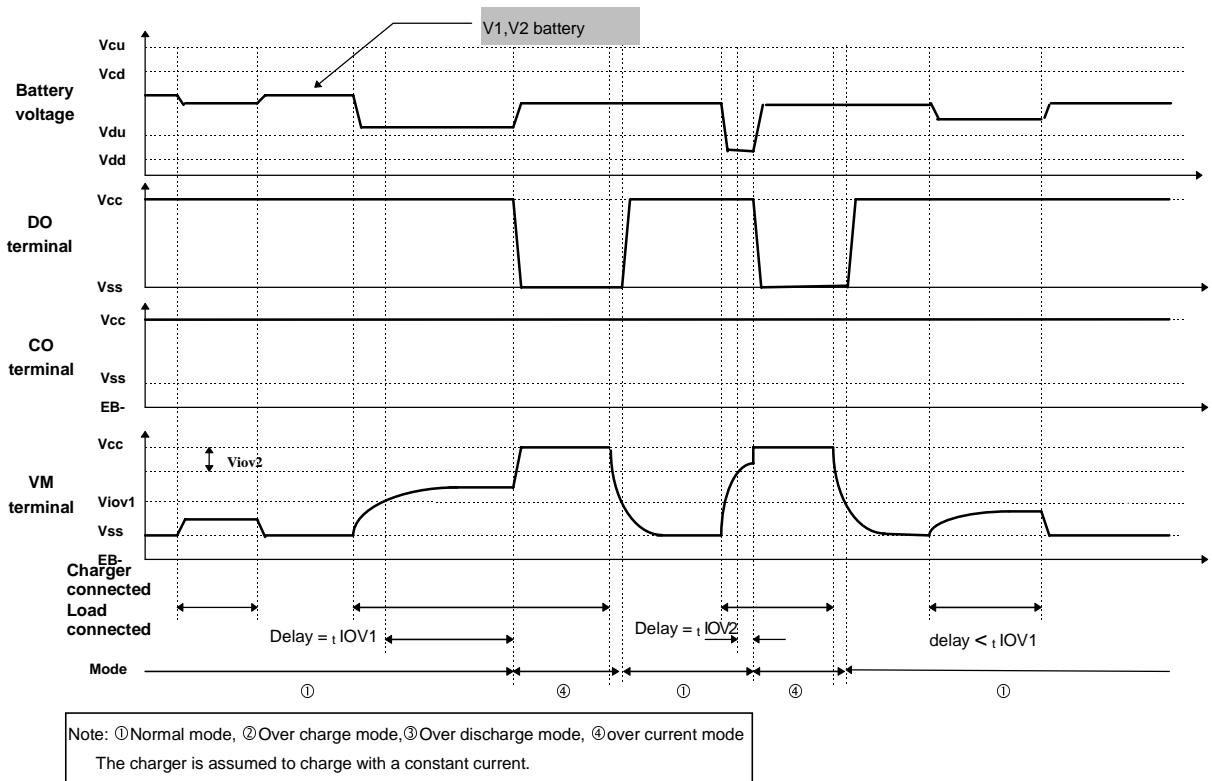

Figure 5

■ Battery Protection IC Connection Example

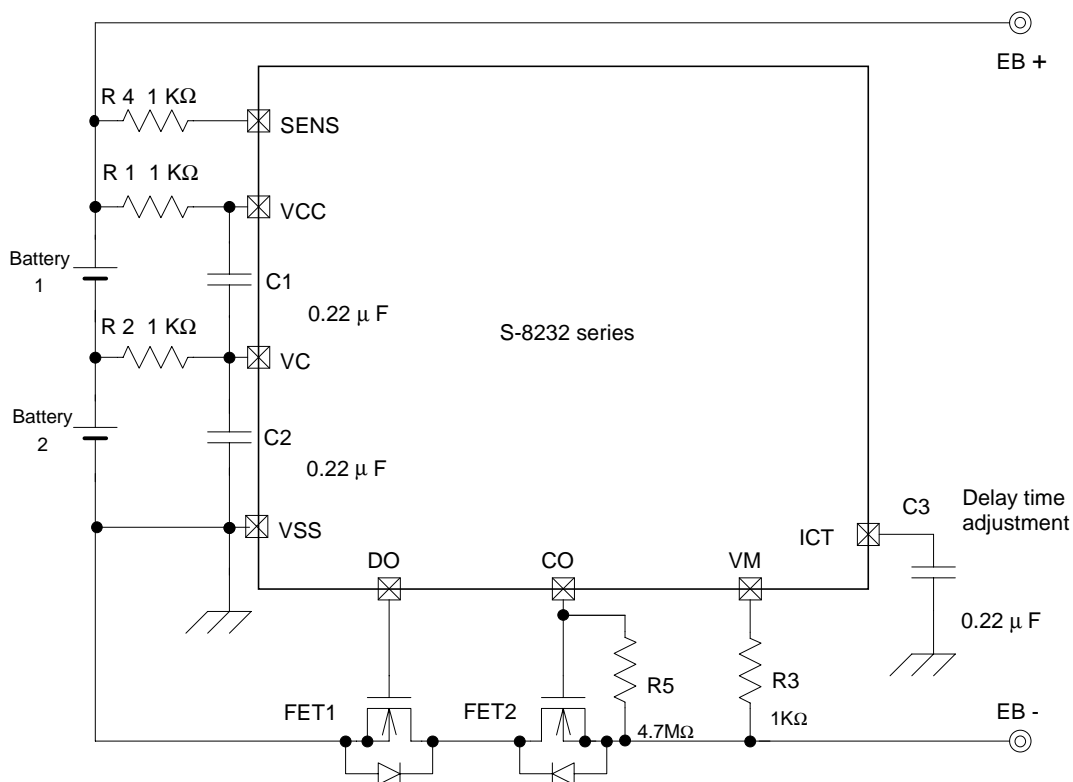

Figure 6

Table 7 Constant

Symbol	Parts	Purpose	Recommend	min.	max.	Remarks
FET1	Nch MOSFET	Charge control	-----	-----	-----	-----
FET2	Nch MOSFET	Discharge control	-----	-----	-----	-----
R1	Chip resistor	For ESD	1KΩ	300Ω	1KΩ	
C1	Chip capacitor	Filter	0.22μF	0μF	1μF	
R2	Chip resistor	For ESD	1KΩ	300Ω	1KΩ	
C2	Chip capacitor	Filter	0.22μF	0μF	1μF	
R4	Chip resistor	For ESD	1KΩ	=R1min	=R1max	*1) Put same value resistor=R1,R2
C3	Chip capacitor	Setting delay time	0.22μF	0μF	1μF	*2) Note leak current of C2
R3	Chip resistor	Protection at reverse connecting of a charger	1KΩ	300Ω	5KΩ	*3) Discharge can't be stopped at less than 300Ω when a charger is connected in reverse.
R5	Chip resistor	0V battery charging prevent	(4.7MΩ)	(1MΩ)	(10MΩ)	*4) lower resistor increase current consumption

- * 1) $R4 = R1$ is required. Overcharge detection voltage is increased by R4. For example 10KW (R4) increase overcharge detection voltage by 20mV.
- * 2) The overcharge detection delay time(t_{CU}), the overdischarge detection delay time(t_{CD}), and the over current detection delay time(t_{IOV}) are changed with external capacitor C3. See the electrical characteristics.
- * 3) R3 is necessary to protect the IC when the charger is connected in reverse. Connect 300W or more. But excessive R3 causes increasing of Overcurrent detection voltage 1 (VIOV1). Please refer the following formulation.
$$D \text{ VIOV1} = (R3 + R_{vsm}) / R_{vsm} \times \text{VIOV1} - \text{VIOV1}$$

For example 50kW(R3) increase Overcurrent detection voltage 1 (VIOV1=0.100V) by 13mV.
- * 4) 4.7M W(R5) prevents 0V battery from charging. Current consumption is increased by R5. Please connect R5 for only 0V charging unavailable type.

!Note:

The above connection diagram and constants do not guarantee proper operations. Evaluate your actual application and set constants properly.

■ Precautions

(1) After the overcurrent detection delay, if the battery voltages is equals the overdischarge detection voltage(VDD1,2) or lower, the overdischarge detection delay time becomes shorter than 10mS(min.). It occurs because capacitor C3 sets all of delay times. (Refer fig.7)

[Cause]

It occurs because capacitor C3 sets all of delay times. When overcurrent detection is released until tIOV1, the capacitor C3 is been charging by S-8232. IF all batteries voltage is lower than VDD1,2 at that time, charging goes on. So delay time is shorter then typical.

[Conclusion]

This phenomenon occurs when all batteries voltage is nearly equal to the overdischarge voltage(VDD1,2) after overcurrent detected. It means that the batteries capacity is small and those must be charged in the future. Even if the state change to overdischarge condition, the battery package capacity is same as typical.

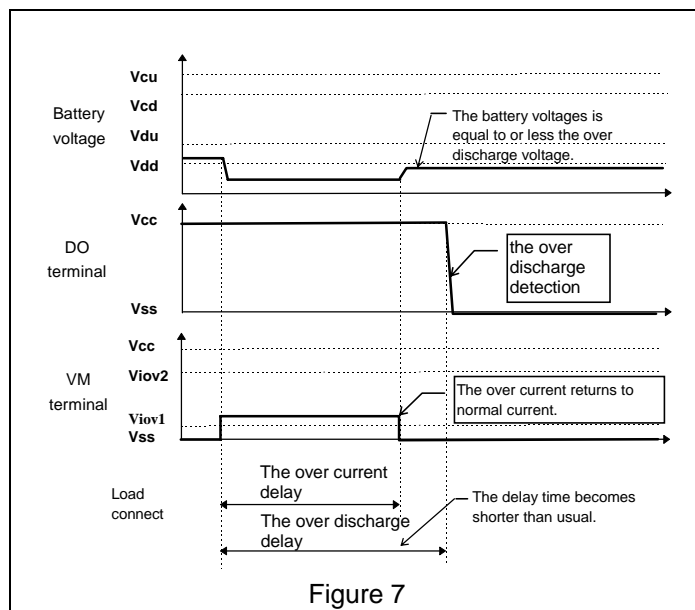

Figure 7

(2) When one of the battery voltages is overdischarge detection voltage(VDD1,2) or lower and the other one becomes higher than the overcharge detection voltage(VCU1,2), the IC detects the overcharge without the overcharge detection delay time(tCU). (Refer fig.8)

[Cause]

It is same as the overdischarge detection under the overcurrent condition. It occurs because capacitor C3 sets all of delay times.

[Conclusion]

This phenomenon occurs when one battery voltage is lower than overdischarge voltage(VDD1,2) and batteries are charged by charger. Under this situation voltage difference between two batteries is unusual. With out delay time is better than long delay time for battery pack safety.(Refer fig.8)

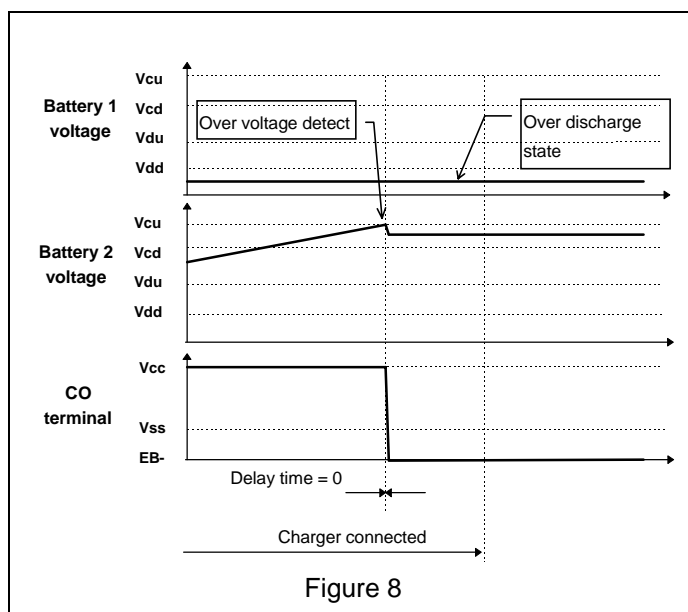

Figure 8

(3) After the overcurrent detection, the load was connected for a long time, even if one of the battery voltage became lower than overdischarge detection voltage ($V_{DD1,2}$), the IC can't detect the overdischarge as long as the load is connected. Therefore the IC's current consumption at the one of the battery voltage is lower than the overdischarge detection voltage is same as normal condition current consumption (IOPE). (Refer fig.9)

[Cause]

The reason is as follows. If the overcurrent detection and overdischarge detection occur at same time, the overcurrent detection takes precedence the overdischarge detection. As long as the IC detects overcurrent, the IC can't detect overdischarge.

[Conclusion]

If the load take off at least one time, the overcurrent release and the overdischarge detection works. Unless keep the IC(S-8232) with load for a long time, the reduction of battery voltage will be neglected, because of the IC's(S-8232) current consumption(typ. 7.5uA) is small.

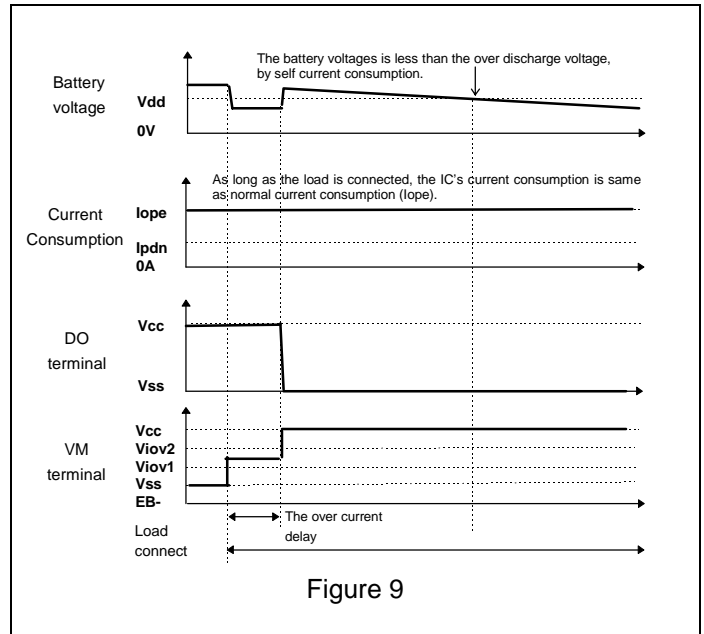

■ Characteristics (typical characteristics)

1. Detection voltage temperature characteristics

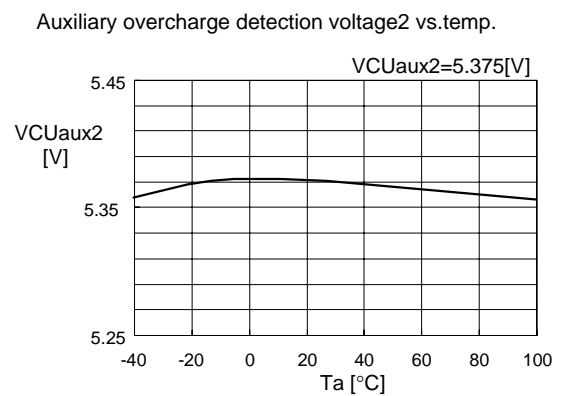
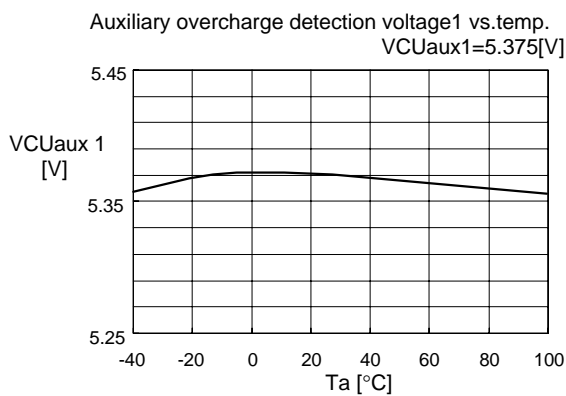
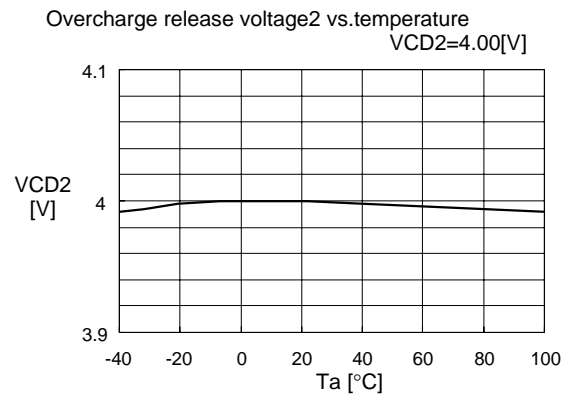
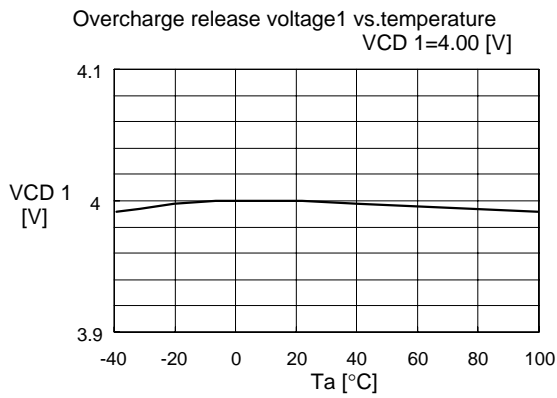
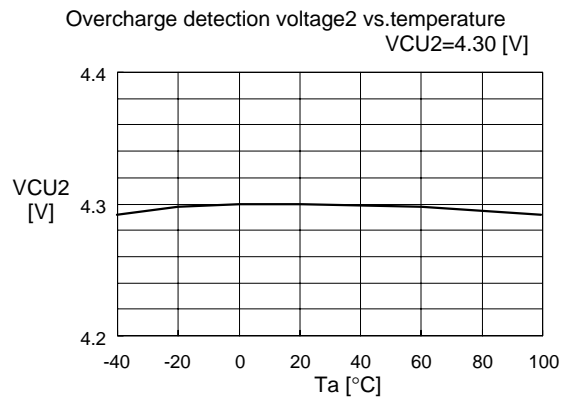
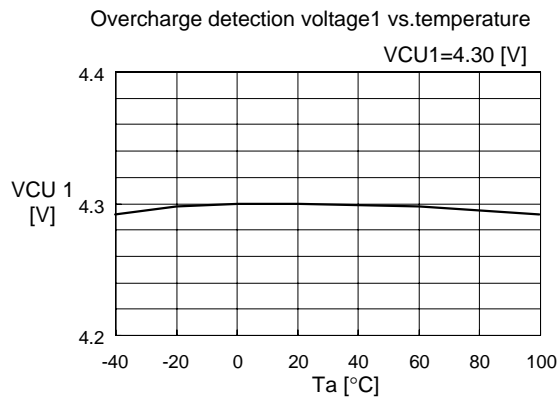

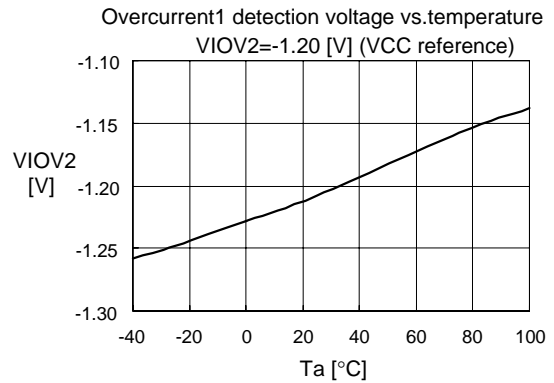
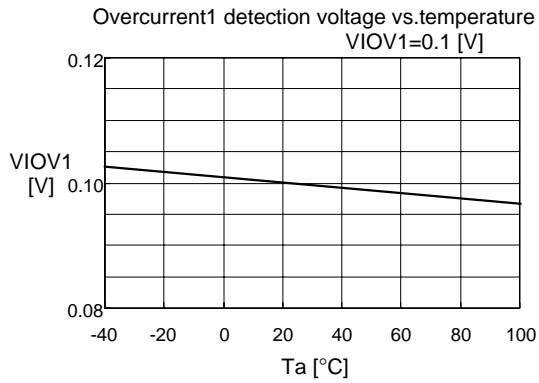
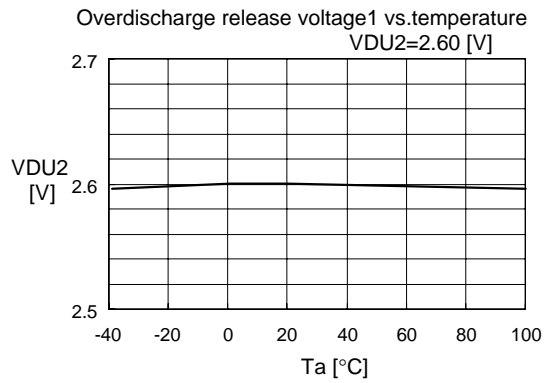
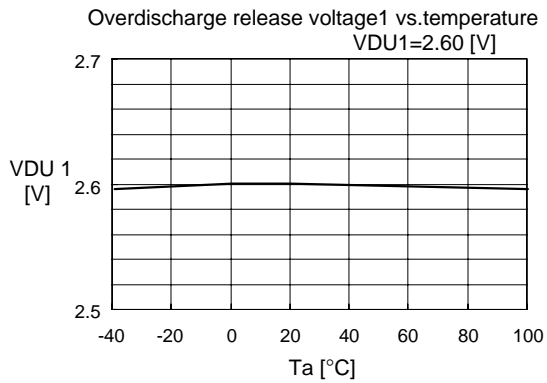
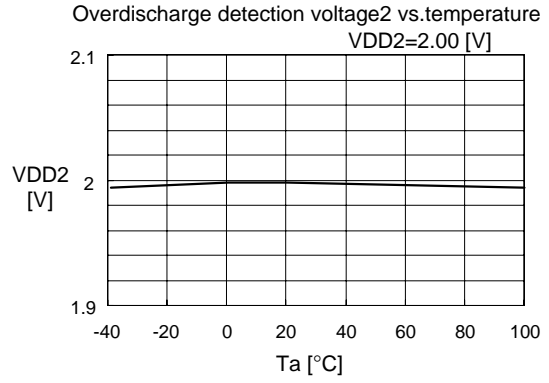
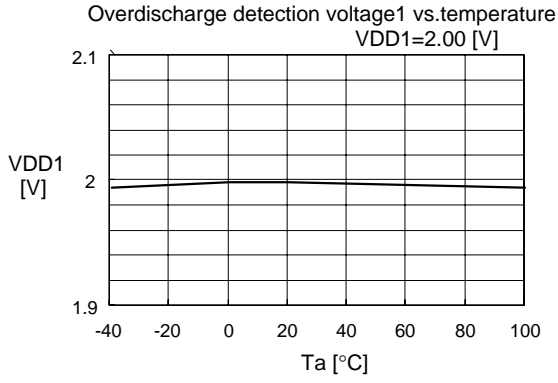

2. Current consumption temperature characteristics

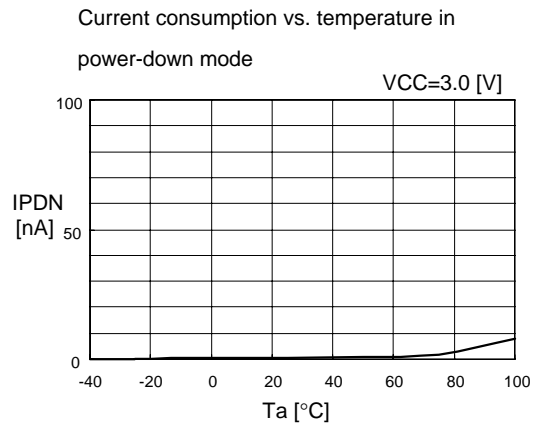
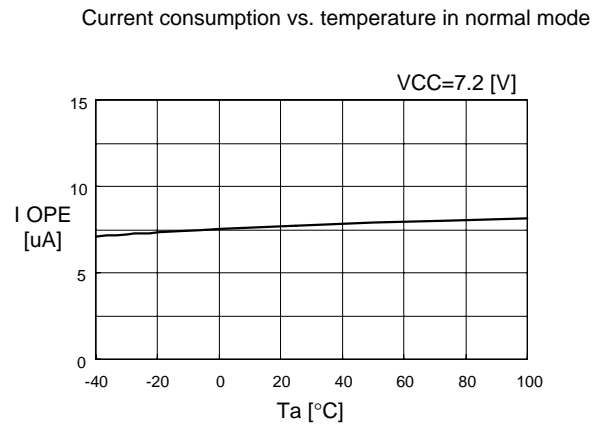

3. Delay time temperature characteristics

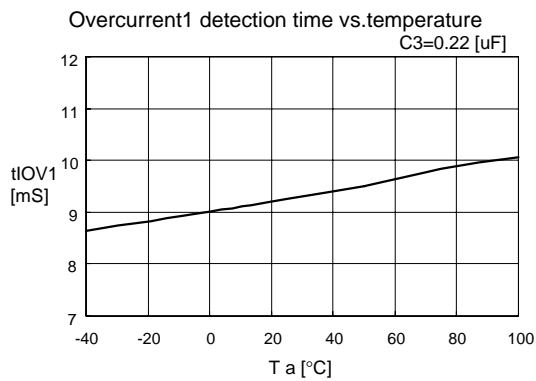
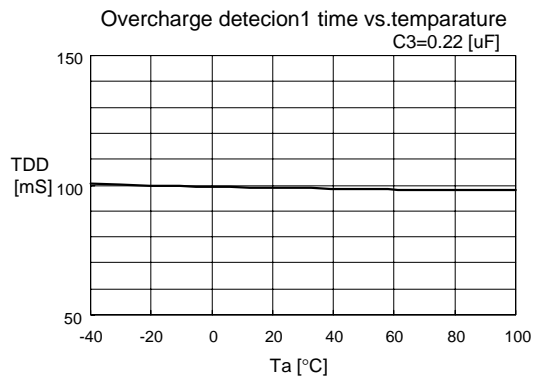
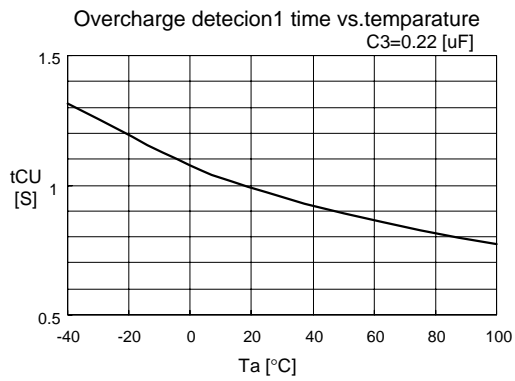

* Please design all applications of the S-8232 Series with safety.

8-pin TSSOP

FT008-A 990531

Dimensions

Unit:mm

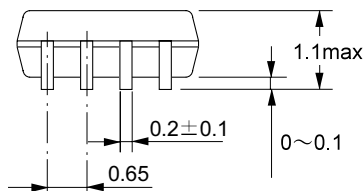
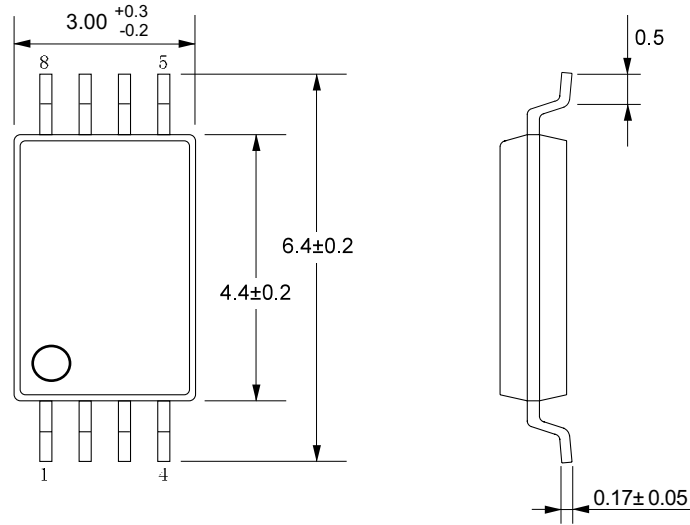

No. : FT008-A-P-SD-1.0

Taping Specifications

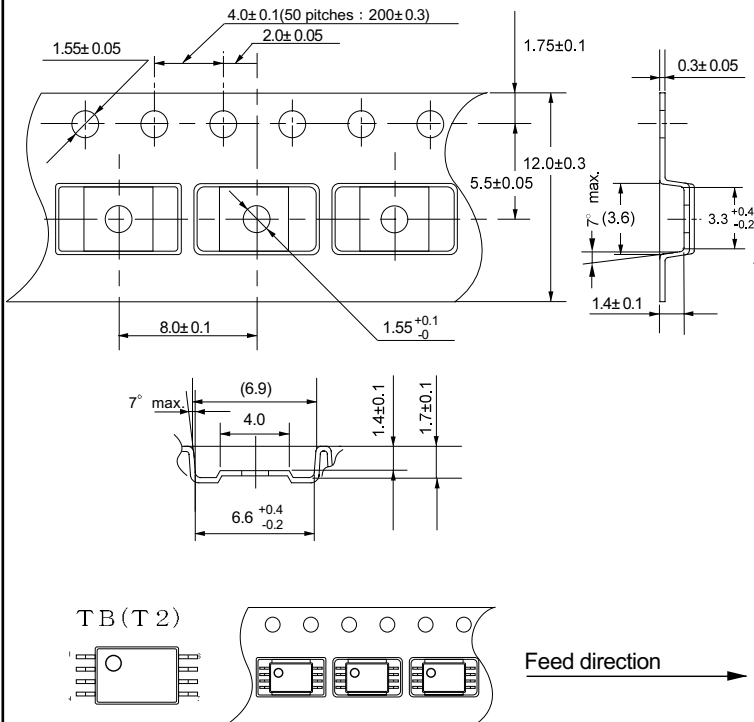

No. : FT008-A-C-SD-1.0

Reel Specifications

1 reel holds 3000 ICs.

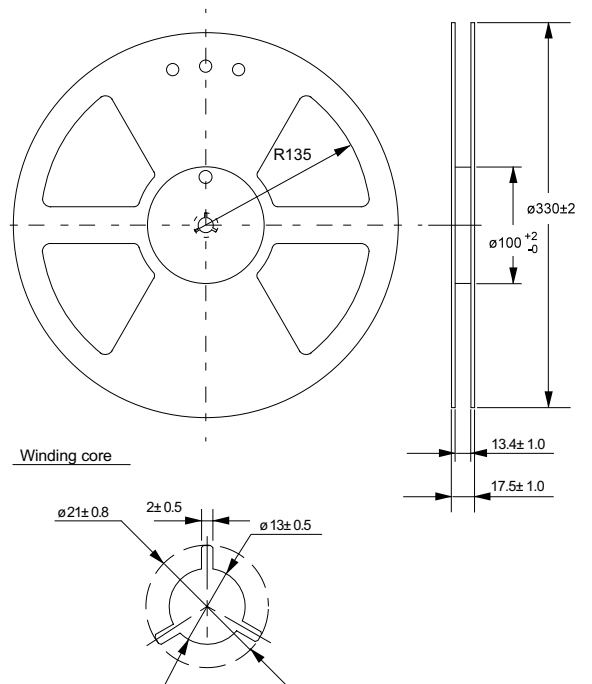

No. : FT008-A-R-SD-1.0

● 8-pin TSSOP

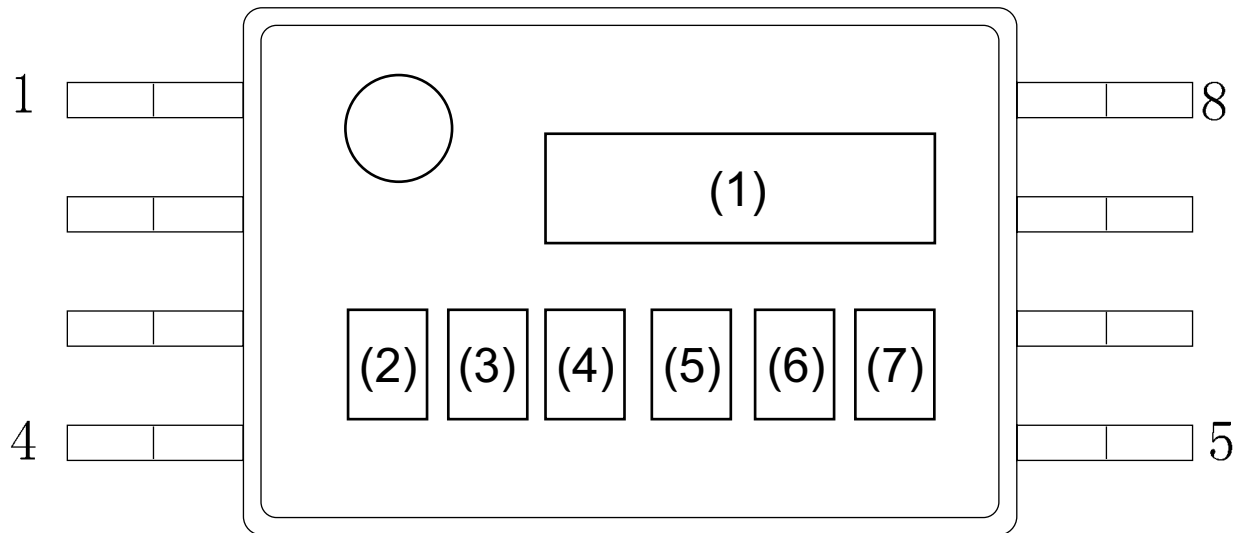

(1) : Product lot

(2) to (7) : Product name

No. : FT008-A-M-S1-1.0

- The information herein is subject to change without notice.
- Seiko Instruments Inc. is not responsible for any problems caused by circuits or other diagrams described herein whose industrial properties, patents or other rights belong to third parties. The application circuit examples explain typical applications of the products, and do not guarantee any mass-production design.
- When the products described herein include Strategic Products (or Service) subject to regulations, they should not be exported without authorization from the appropriate governmental authorities.
- The products described herein cannot be used as part of any device or equipment which influences the human body, such as physical exercise equipment, medical equipment, security system, gas equipment, vehicle or airplane, without prior written permission of Seiko Instruments Inc.