

## External Transistor Type Voltage Regulators

## S-816 Series

The S-816 Series consists of external transistor type positive voltage regulators, which have been developed using the CMOS process. These voltage regulators incorporate an overcurrent protection, and power-off function. A low drop-out type regulator with an output current ranging from several hundreds of mA to 1A can be configured with the PNP transistor driven by this IC.

Despite the features of the S-816, which is low current consumption, the improvement in its transient response characteristics of the IC with a newly devised phase compensation circuit made it possible to employ the products of the S-816 Series even in applications where heavy input variation or load variation is experienced.

The S-816 Series regulators serve as ideal power supply units for portable devices when coupled with the SOT-23-5 minipackage, providing numerous outstanding features, including low current consumption. Since this series can accommodate an input voltage of up to 16V, it is also suitable when operating via an AC adapter.

### ■ Features

- Low current consumption In operation : 30  $\mu$  A typ.  
40  $\mu$  A max.  
When powered-off : 1  $\mu$  A max.
- Input voltage range : 16V max.
- Output voltage accuracy :  $\pm 2.0\%$
- Output voltage range : Selectable between 2.5V and 6.0V in steps of 0.1V.
- With power-off function.
- A built-in current source (10  $\mu$ A) eliminates the need of a base-emitter resistance.
- With overcurrent (base current) protection function.

### ■ Applications

- On-board power supplies of battery devices for portable telephones, electronic notebooks, PDAs, and the like.
- Fixed voltage power supplies for cameras, video equipment and portable communications equipment.
- Power Supplies for CPUs.
- Post-Regulators for Switching Regulators.
- Main Regulators in Multiple-Power Supply Systems.

### ■ Block Diagram

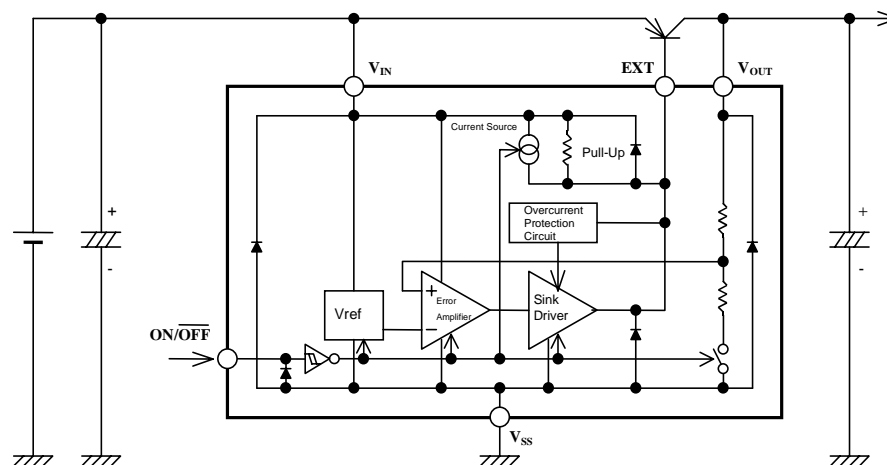

Note: To ensure you power cutoff of the external transistor when the device is powered down, the EXT output is pulled up to VIN by a pull-up resistance (approx. 0.5M $\Omega$ ) inside the IC. The diode inside the IC is a parasitic diode.

Figure 1. Block Diagram

■ Selection Guide

1. Product Name

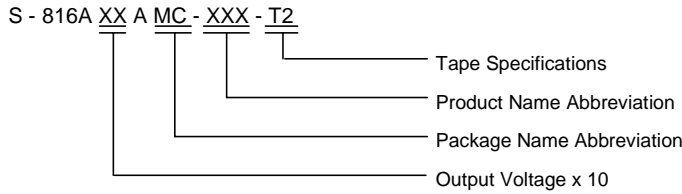

2. Product List (As of May 28, 1998)

Output Voltage (V)	SOT-23-5
2.5V±2.0%	S-816A25AMC-BAA-T2
2.6V±2.0%	—
2.7V±2.0%	—
2.8V±2.0%	—
2.9V±2.0%	—
3.0V±2.0%	S-816A30AMC-BAF-T2
3.1V±2.0%	—
3.2V±2.0%	—
3.3V±2.0%	S-816A33AMC-BAI-T2
3.4V±2.0%	—
3.5V±2.0%	—
3.6V±2.0%	—
3.7V±2.0%	S-816A37AMC-BAM-T2
3.8V±2.0%	—
3.9V±2.0%	—
4.0V±2.0%	S-816A40AMC-BAP-T2
4.1V±2.0%	—
4.2V±2.0%	—

Output Voltage (V)	SOT-23-5
4.3V±2.0%	—
4.4V±2.0%	—
4.5V±2.0%	—
4.6V±2.0%	—
4.7V±2.0%	—
4.8V±2.0%	—
4.9V±2.0%	—
5.0V±2.0%	S-816A50AMC-BAZ-T2
5.1V±2.0%	—
5.2V±2.0%	—
5.3V±2.0%	—
5.4V±2.0%	—
5.5V±2.0%	—
5.6V±2.0%	—
5.7V±2.0%	—
5.8V±2.0%	—
5.9V±2.0%	—
6.0V±2.0%	—

Please contact the SII Sales Department regarding the availability of samples.

■ Pin Assignment

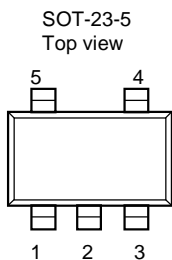

Figure 2

Terminal No.	Terminal Name	Function
1	EXT	Output Terminal for Base-Current Control
2	V <sub>SS</sub>	GND Terminal
3	ON/OFF	Power-Off Terminal ("H" active)
4	V <sub>IN</sub>	IC Power Supply Terminal
5	V <sub>OUT</sub>	Output Voltage Monitoring Terminal

## ■ Absolute Maximum Ratings

Note: Although the IC contains protection circuit against static electricity, excessive static electricity or voltage which exceeds the limit of the protection circuit should not be applied to.

(Ta = 25°C, unless otherwise specified)

Item	Symbol	Ratings	Unit
V <sub>IN</sub> Terminal Voltage	V <sub>IN</sub>	V <sub>SS</sub> -0.3 to V <sub>SS</sub> +18	V
V <sub>OUT</sub> Terminal Voltage	V <sub>OUT</sub>	V <sub>SS</sub> -0.3 to V <sub>SS</sub> +18	V
ON/OFF Terminal Voltage	ON/OFF	V <sub>SS</sub> -0.3 to V <sub>SS</sub> +18	V
EXT Terminal Voltage	V <sub>EXT</sub>	V <sub>SS</sub> -0.3 to V <sub>IN</sub> +0.3	V
EXT Terminal Current	I <sub>EXT</sub>	50	mA
Power Dissipation	PD	150	mW
Operating Temperature Range	TOPR	-40 to +85	°C
Storage Temperature Range	TSTG	-40 to +125	°C

## ■ Electrical Characteristics

(Ta = 25°C, unless otherwise specified)

Item	Symbol	Conditions	Min.	Typ.	Max.	Unit	Meas. Circuit
Input Voltage	V <sub>IN</sub>		-	-	16	V	1
Output Voltage	V <sub>OUT</sub>	V <sub>IN</sub> = V <sub>OUT</sub> + 1V, I <sub>OUT</sub> = 50mA ON/OFF = "H"	V <sub>OUT</sub> X 0.98	V <sub>OUT</sub>	V <sub>OUT</sub> X 1.02	V	1
Maximum Output Current (PNP Output) *1			-	1	-	A	1
Drop-Out Voltage *1	ΔV <sub>drop</sub>	I <sub>OUT</sub> = 100mA	-	100	-	mV	1
Load Regulation (PNP Output) *1	ΔV <sub>OUT</sub>	V <sub>IN</sub> = V <sub>OUT</sub> + 1V, 1mA < I <sub>OUT</sub> < 1A	-	-	60	mV	1
Line Regulation (PNP Output) *1	ΔV <sub>OUT</sub> V <sub>OUT</sub> x ΔV <sub>IN</sub>	I <sub>OUT</sub> = 50mA, V <sub>OUT</sub> + 1V < V <sub>IN</sub> < 16V	-0.15	0.01	0.15	%/V	1
Output Voltage Temperature Coefficient	ΔV <sub>OUT</sub> ΔTa	V <sub>IN</sub> = V <sub>OUT</sub> + 1V, I <sub>OUT</sub> = 50mA ON/OFF = "H", Ta = -40 to 85 °C	-	±0.15	-	mV/°C	1
Current Consumption during Operation	I <sub>SS</sub>	V <sub>IN</sub> = V <sub>OUT</sub> + 1V, ON/OFF = "H"	-	30	40	μA	1
Current Consumption during Power-Off	I <sub>STB</sub>	V <sub>IN</sub> = 16V, ON/OFF = "L"	-	-	1	μA	1
EXT Output Source Constant Current	I <sub>src</sub>	V <sub>IN</sub> = V <sub>OUT</sub> + 1V, ON/OFF = "H" EXT = V <sub>OUT</sub> , V <sub>OUT</sub> = V <sub>OUT</sub> x 0.95	-	-10	-	μA	2
EXT Output Pull-Up Resistance	R <sub>up</sub>	V <sub>IN</sub> = 16V, ON/OFF = "L"	0.25	0.50	1.00	MΩ	2
EXT Output Sink Current	I <sub>sink</sub>	V <sub>IN</sub> = V <sub>OUT</sub> + 1V, ON/OFF = "H" V <sub>OUT</sub> = V <sub>OUT</sub> x 0.95	-	10	-	mA	2
Leakage Current during EXT Output Off	I <sub>off</sub>	V <sub>IN</sub> = EXT = V <sub>OUT</sub> + 1V, V <sub>OUT</sub> = 0V ON/OFF = "L"	-	-	0.1	μA	2
EXT Output Sink Overcurrent Set Value	I <sub>max</sub>	V <sub>IN</sub> = EXT = 7V, ON/OFF = "H" V <sub>OUT</sub> = V <sub>OUT</sub> x 0.95	12	16	20	mA	2
Power-Off Terminal Input Voltage	V <sub>SH</sub>	Check V <sub>IN</sub> = V <sub>OUT</sub> + 1V, V <sub>OUT</sub> = 0V, EXT = "L"	2.4	-	-	V	3
	V <sub>SL</sub>	Check V <sub>IN</sub> = V <sub>OUT</sub> + 1V, V <sub>OUT</sub> = 0V, EXT = "H"	-	-	0.3	V	3
Power-Off Terminal Input Current	I <sub>SH</sub>	ON/OFF = V <sub>OUT</sub> + 1V	-	-	0.1	μA	2
	I <sub>SL</sub>	ON/OFF = 0V	-	-	-0.1	μA	2

\*1 The characteristics vary with the associated external components.

The characteristics given above are those obtained when the IC is combined with a Toshiba 2SA1213-Y for the PNP transistor and a 10 μF tantalum capacitor for the output capacitor (CL).

■ Measurement Circuits

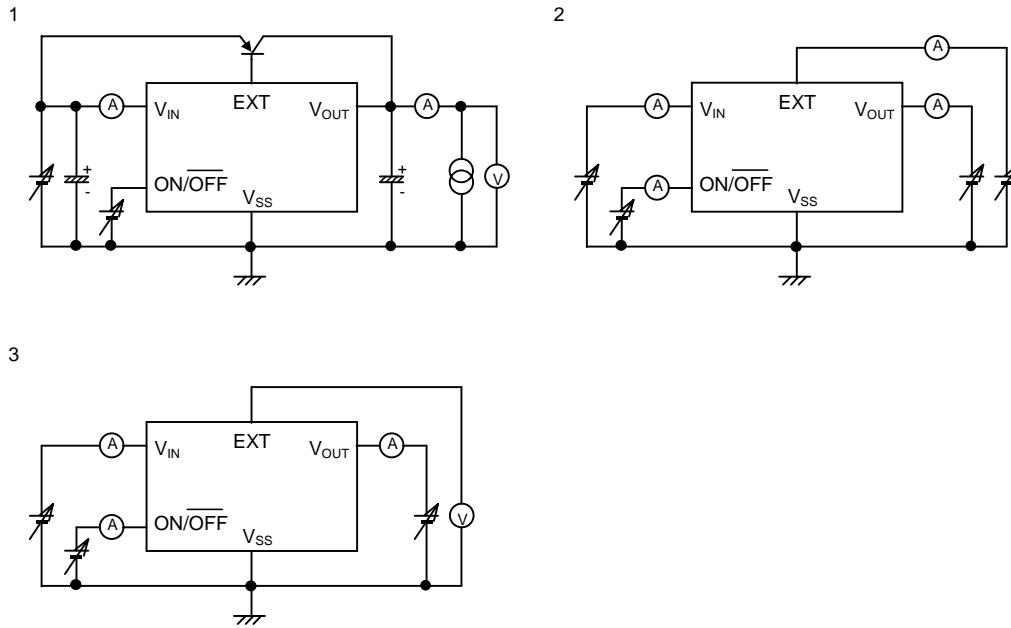

Figure 3

■ Operation

1. Basic Operation

Figure 4 shows a block diagram of the S-816 Series.

The device compares the voltage which is obtained from dividing output voltage  $V_{OUT}$  by feedback resistances  $R_A$  and  $R_B$  with reference voltage  $V_{ref}$  through the error amplifier, output of which controls the sink driver. By regulating the base current of the external PNP transistor, the IC maintains a constant output voltage that is not susceptible to an input voltage variation or temperature variation.

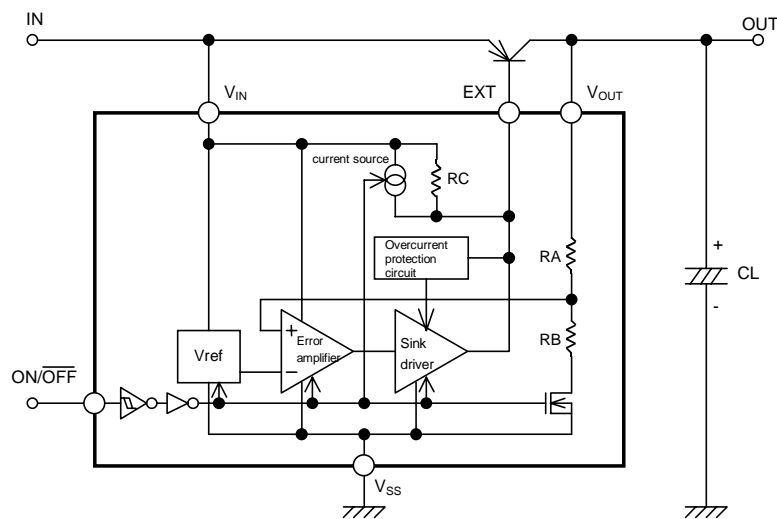

Figure 4

## 2. Internal Circuits

### 2.1 Power-Off Terminal (ON/OFF Terminal)

This terminal activates and deactivates the regulating operation.

When the power-off terminal is set to "L", the  $V_{IN}$  voltage appears through the EXT terminal, prodding the external PNP transistor to off. All the internal circuits stop working, and substantial savings in current consumption are achieved accordingly. In this condition, the EXT terminal is pulled up to  $V_{IN}$  by a pull-up resistance (approx.  $0.5M\ \Omega$ ) inside the IC in order to ensure you power cut off of the external PNP transistor.

The power-off terminal is configured as shown in Figure 5. Since neither pull-up or pull-down is performed internally, please avoid using the terminal in a floating state. Also, be sure to refrain from applying a voltage of 0.3V to 2.4V to this terminal lest the current consumption increase. When this power-off terminal is not used, leave it coupled to the  $V_{IN}$  terminal.

Power-Off Terminal	Internal Circuit	EXT Terminal Voltage	$V_{OUT}$ Terminal Voltage
"H"	Activated	$V_{IN}-V_{BE}$	Set value
"L"	Deactivated	$V_{IN}$	Hi-z

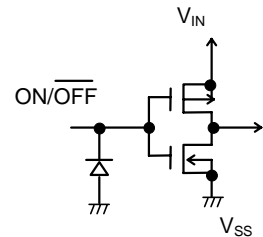

Figure 5

### 2.2 Overcurrent Protection Circuit

The overcurrent protection function of the S-816 Series monitors the EXT terminal sink current (base current of the external PNP transistor) with an overcurrent protection circuit incorporated in the IC, and limits that current (EXT terminal sink current).

As the load current increases, the EXT terminal sink current (base current of the external PNP transistor) also grows larger to maintain the output voltage. The overcurrent protection circuit clamps and limits the EXT terminal sink current to the EXT output sink overcurrent set value ( $I_{max}$ ) in order to prevent it from increasing beyond that value.

The load current at which the overcurrent protection function works is represented by the following equation:

$$I_{out\_max} = I_{max} \times h_{fe}$$

In this case,  $h_{fe}$  is the DC amplification factor of the external PNP transistor.

$I_{out\_max}$  represents the maximum output current of this regulator. If it is attempted to obtain a higher load current, the output voltage will fall.

Note that within the overcurrent protection function of this IC, the external PNP transistor may not be able to be protected from collector overcurrents produced by an EXT-GND short-circuiting or other phenomenon occurring outside the IC. To protect the external PNP transistor from such collector overcurrents, it will be necessary to choose a transistor with a larger power dissipation than  $I_{out\_max} \times V_{IN}$ , or to add an external overcurrent protection circuit. With regard to this external overcurrent protection circuit, please refer to "Application Circuits and Overcurrent Protection Circuit".

### 2.3 Phase Compensation Circuit

The S-816 Series performs phase compensation with a phase compensation circuit, incorporated in the IC, and the ESR (Equivalent Series Resistance) of an output capacitor, to secure stable operation even in the presence of output load variation. A uniquely devised phase compensation circuit has resulted in improved transient response characteristics of the IC, while preserving the same feature of low current consumption. This feature allows the IC to be used in applications where the input variation or load variation is heavy.

Because the S-816 Series is designed to perform the phase compensation, utilizing the ESR of an output capacitor, such output capacitor (CL) should always be placed between  $V_{OUT}$  and  $V_{SS}$ . Since each capacitor to be employed has an optimum range of their own characteristics, be sure to choose components for the IC with your all attention. For details, refer to "Selection of Associated External Components."

## ■ Selection of Associated External Components

### 1. External PNP transistor

Select an external transistor according to the conditions of input voltage, output voltage, and output current. A low-saturation voltage PNP transistor with 'hfe' ranging from 100 to 300 will be suitable for this IC.

The parameters for selection of the external PNP transistor include the maximum collector-base voltage, the maximum collector-emitter voltage, the DC amplification factor (hfe), the maximum collector current and the collector dissipation.

The maximum collector-base voltage and the maximum collector-emitter voltage are determined by the input voltage range in each specific application to be employed. You may select a transistor with an input voltage at least several volts higher than the expected maximum input voltage.

The DC amplification factor (hfe) affects the maximum output current that can be supplied to the load.

With an internal overcurrent protection circuit of this IC, the base current is clamped, and will not exceed the overcurrent set value ( $I_{max}$ ). Select a transistor which is capable of delivering the required maximum output current to the intended application, with hfe and maximum collector current. (See the paragraph of Overcurrent Protection Circuit)

Likewise, select a transistor, based on the maximum output current and the difference between the input and output voltages, with due attention to the collector dissipation.

### 2. Output Capacitor (CL)

The S-816 Series performs phase compensation by an internal phase compensation circuit of IC, and the ESR (Equivalent Series Resistance) of an output capacitor for to secure stable operation even in the presence of output load variation. Therefore, always place a capacitor (CL) of 4.7 $\mu$ F or more between  $V_{OUT}$  and  $V_{SS}$ .

For stable operation of the S-816 Series, it is essential to employ a capacitor with an ESR having optimum range. Whether an ESR is larger or smaller than that optimum range (approximately 0.1 $\Omega$  to 5 $\Omega$ ), this could produce an unstable output, and cause a possibility of oscillations. For this reason, a tantalum electrolytic capacitor is recommended.

When a ceramic capacitor or an OS capacitor having a low ESR is selected, it will be necessary to connect an additional resistance that serves for the ESR in series with the output capacitor, as illustrated in Figure 6. The resistance value that needs to be added will be from 0.1 $\Omega$  to 5 $\Omega$ , but this value may vary depends on the service conditions, and should be defined through careful evaluation in advance. In general, our recommendation is 0.3 $\Omega$  or so.

An aluminum electrolytic capacitor tends to produce oscillations as its ESR increases at a low temperature. Beware of this case. When this type of capacitor is employed, make thorough evaluation of it, including its temperature characteristics.

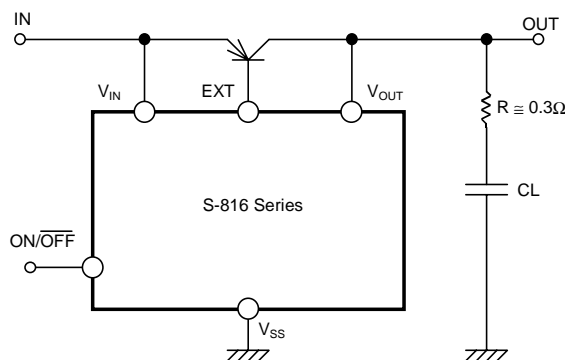

Figure 6

■ Standard Circuit

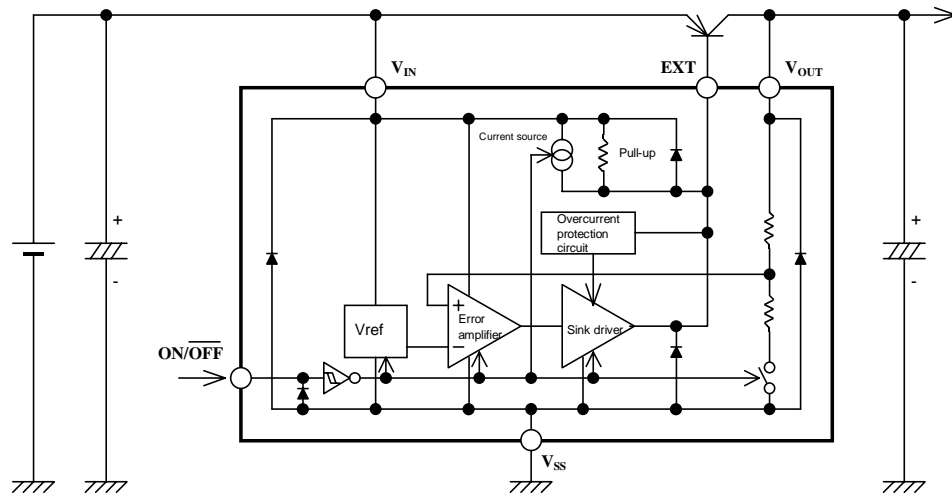

Figure 7

■ Precautions

- The overcurrent protection function of this IC detects and limits the sink current at the EXT terminal inside the IC. Therefore, it does not work on collector overcurrents which are caused by an EXT-GND short-circuiting or other phenomenon outside the IC. To protect the external PNP transistor from collector overcurrents perfectly, it is necessary to provide another external overcurrent protection circuit.
- This IC performs phase compensation by using an internal phase compensator circuit and the ESR of an output capacitor. Therefore, always place a capacitor of 4.7uF or more between V<sub>OUT</sub> and V<sub>SS</sub>. A tantalum type capacitor is recommended for this purpose. Moreover, to secure stable operation of the S-816 Series, it will be necessary to employ a capacitor having an ESR (Equivalent Series Resistance) covered in a certain optimum range (0.1Ω to 5Ω). Whether an ESR is larger or smaller than that optimum range, this could result in an unstable output, and cause a possibility of oscillations. Select a capacitor through careful evaluation made according to the actual service conditions.
- Make sure that the power dissipation inside the IC due to the EXT output sink current (especially at a high temperature) will not surpass the power dissipation of the package.

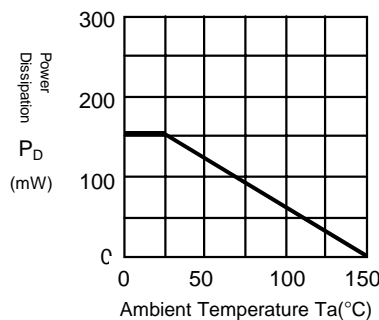

Figure 8. Power Dissipation of SOT-23-5 Package (When Not Mounted)

- Seiko Instruments Inc. shall not be responsible for any patent infringement by products including the S-816 Series in connection with the method of using the S-816 in such products, the product specifications or the country of destination thereof.

■ Application Circuits

1. Overcurrent protection circuit

Figure 9 shows a sample of overcurrent protection implemented with an external circuit connected.

The internal overcurrent protection function of the S-816 Series is designed to detect the sink current (base current of the PNP transistor) at the EXT terminal, therefore it may not be able to protect the external PNP transistor from collector overcurrents caused by an EXT-GND short-circuiting or other phenomenon occurring outside the IC.

This sample circuit activates the regulator intermittently against collector overcurrents, thereby suppressing the heat generation of the external PNP transistor.

The duty of the on-time and off-time of the intermittent operation can be regulated through an external component.

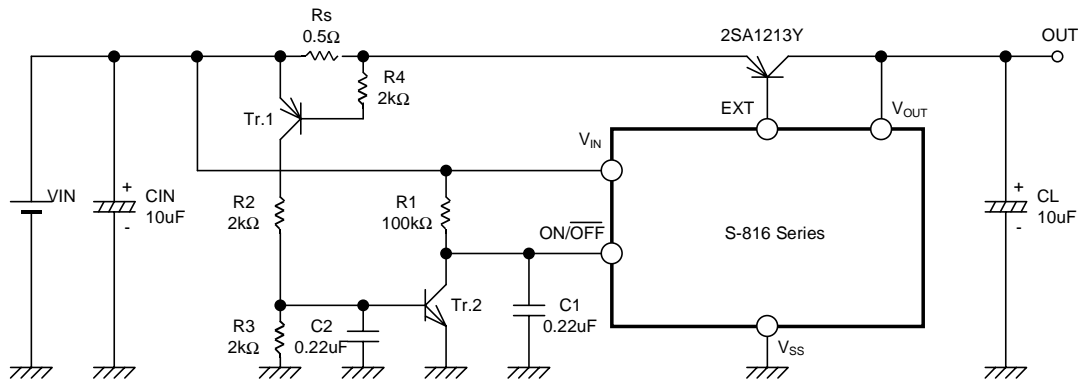

Figure 9

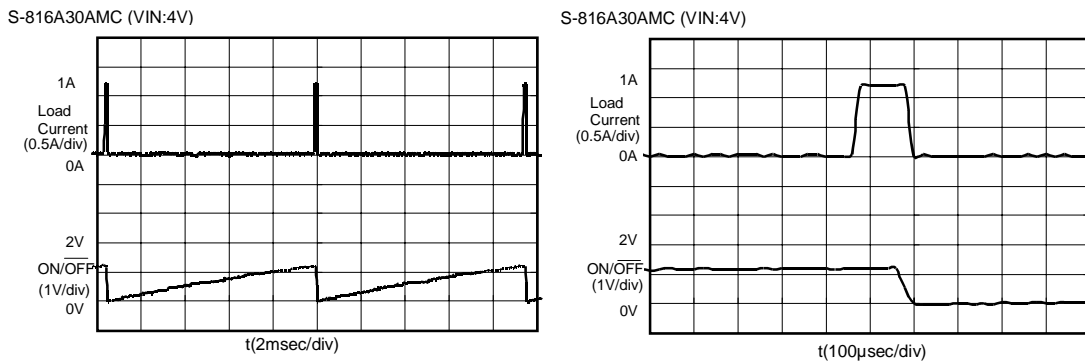

Figure 10. Output Current Waveforms during Intermittent Operation Prompted by Load Short-Circuiting

The detection of the overcurrent is done by the sense resistance (Rs) and the PNP transistor (Tr.1). When Tr.1 comes on, triggered by a voltage drop of Rs, the NPN transistor (Tr.2) also comes on, according to the time constants of the capacitor (C2) and resistance (R2). This causes the power-off terminal to turn to the 'L' level, and the regulating operation to stop, and interrupting the current to the load.

When the load current is cut off, the voltage drop of Rs stops. This makes Tr.1 off again, and also makes the NPN transistor (Tr.2) off.

In this condition, the power-off terminal returns to the 'H' level, according to the time constants of the capacitor (C1) and resistance (R1). This delay time in which power-off terminal returns to the 'H' level from the 'L' level is the time in which the load current remains cut off.

If an overcurrent flows again after the power-off terminal has assumed the 'H' level following the delay time and the regulating operation has been restarted, the circuit will again suspend the regulating operation and resume the intermittent operation. This intermittent operation will be continued till the overcurrent is eliminated, and once the overcurrent disappears, the normal operation will be restored.



The overcurrent detection value ( $I_{out\_max}$ ) is represented by the following equation:

$$I_{out\_max} = |V_{BE1}| / R_s$$

In this case,  $R_s$  denotes the resistance value of the sense resistance, and  $V_{BE1}$  denotes the base-emitter saturation voltage of Tr.1.

For the PNP transistor (Tr.1) and the NPN transistor (Tr.2), try to select those of small-signal type that offer a sufficient withstand voltage against the input voltage ( $V_{IN}$ ).

The on-time ( $T_{on}$ ) and the off-time ( $T_{off}$ ) of the intermittent operation are broadly expressed by the following equations:

$$T_{on} = -1 \times C_2 \times R_2 \times \ln(1 - (V_{BE2} \times (1 + R_2 / R_3)) / (V_{IN} - V_{BE1}))$$

$$T_{off} = -1 \times C_1 \times R_1 \times \ln(1 - V_{SH} / V_{IN})$$

In this case,  $V_{BE2}$  denotes the base-emitter saturation voltage of Tr.2,  $V_{IN}$  denotes the input voltage, and  $V_{SH}$  denotes the inversion voltage (L→H) of the power-off terminal.

Set the on-time value that does not cause the overcurrent protection to be activated by a rush current to the load capacitor. Then, compute the ratio between the on-time and the off-time from the maximum input voltage of the appropriate application and the power dissipation of the external PNP transistor, and decide the off-time with reference to the on-time established earlier.

Take the equation above as a rough guide, because the actual on-time ( $T_{on}$ ) and off-time ( $T_{off}$ ) should be defined and checked using the utilizing components.

## 2. External adjustment of output voltage

The S-816 Series allows you to adjust the output voltage or to set its value over the output voltage range (6V) of the products of this series, when external resistances  $R_A$ ,  $R_B$  and capacitor  $C_C$  are added, as illustrated in Figure 11. Moreover, a temperature gradient can be obtained by inserting a thermistor or other element in series with external resistances  $R_A$  and  $R_B$ .

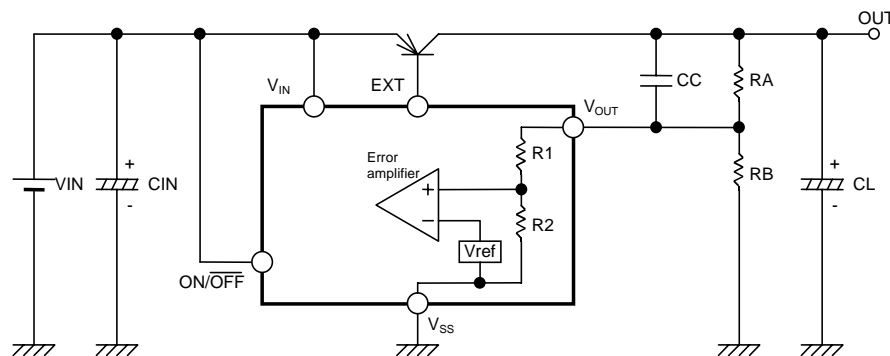

Figure 11

The S-816 Series has an internal impedance resulting from  $R_1$  and  $R_2$  between the  $V_{OUT}$  and the  $V_{SS}$  terminal, as shown in Figure 11. Therefore, the influence of the internal resistances ( $R_1$ ,  $R_2$ ) of the IC has to be taken into consideration in defining the output voltage (OUT).

The output voltage (OUT) is expressed by the following equation:

$$OUT = V_{OUT} + V_{OUT} \times RA \div (RB \parallel RI) \quad (\text{Note: } \parallel \text{ denotes a combined resistance in parallel.})$$

In this case,  $V_{OUT}$  is the output voltage value of the S-816 Series,  $R_A$  and  $R_B$  is the resistance values of the external resistances, and  $RI$  is the resistance value ( $R_1+R_2$ ) of the internal resistances in the IC.

The accuracy of the output voltage (OUT) is determined by the absolute accuracy of external connecting resistances  $R_A$  and  $R_B$ , the output voltage accuracy ( $V_{OUT} \pm 2.0\%$ ) of the S-816 Series, and deviations in the absolute value of the internal resistance ( $RI$ ) in the IC.

The maximum value ( $OUT_{max}$ ) and the minimum value ( $OUT_{min}$ ) of the output voltage (OUT), including deviations, are expressed by the following equations:

$$OUT_{max} = V_{OUT} \times 1.02 + V_{OUT} \times 1.02 \times R_{Amax} \div (R_{Bmin} \parallel R_{Imin})$$

$$OUT_{min} = V_{OUT} \times 0.98 + V_{OUT} \times 0.98 \times R_{Amin} \div (R_{Bmax} \parallel R_{Imax})$$

Where  $R_{Amax}$ ,  $R_{Amin}$ ,  $R_{Bmax}$  and  $R_{Bmin}$  denote the maximum and minimum of the absolute accuracy of external resistances  $R_A$  and  $R_B$ , and  $R_{Imax}$  and  $R_{Imin}$  denote the maximum and minimum deviations of the absolute value of the internal resistance ( $R_I$ ) in the IC, respectively.

The deviations in the absolute value of internal resistance ( $R_I$ ) in the IC vary with the output voltage set value of the S-816 Series, and are broadly classified as follows:

- Output voltage(V<sub>OUT</sub>) 2.5V to 2.7V ⇒ 3.29MΩ to 21.78MΩ
- Output voltage(V<sub>OUT</sub>) 2.8V to 3.1V ⇒ 3.29MΩ to 20.06MΩ
- Output voltage(V<sub>OUT</sub>) 3.2V to 3.7V ⇒ 2.23MΩ to 18.33MΩ
- Output voltage(V<sub>OUT</sub>) 3.8V to 5.1V ⇒ 2.23MΩ to 16.61MΩ
- Output voltage(V<sub>OUT</sub>) 5.2V to 6.0V ⇒ 2.25MΩ to 14.18MΩ

If a value of  $R_I$  given by the equation shown below is taken in calculating the output voltage (OUT), a median voltage deviation of the output voltage (OUT) will be obtained.

$$R_I = 2 \div ( 1 \div (\text{Maximum value of internal resistance of IC}) + 1 \div (\text{Minimum value of internal resistance of IC}) )$$

The closer the output voltage (OUT) and the output voltage set value (V<sub>OUT</sub>) of the IC are brought to each other, the more the accuracy of the output voltage (OUT) remains immune to deviations in the absolute accuracy of external resistances ( $R_A$  and  $R_B$ ) and the absolute value of the internal resistance ( $R_I$ ) of the IC.

In particular, to suppress the influence of deviations in the internal resistance ( $R_I$ ), the resistance values of external resistances ( $R_A$ ,  $R_B$ ) need to be limited to a much smaller value than that of the internal resistance ( $R_I$ ). However, since reactive current flows through the external resistances ( $R_A$ ,  $R_B$ ), there is a tradeoff between the accuracy of the output voltage (OUT) and the reactive current. This should be taken into consideration, according to the requirements of the intended application.

Note that when larger value (more than 1MΩ) is taken for the external resistances ( $R_A$ ,  $R_B$ ), IC is vulnerable to external noise. Check the influence of this value well with the actual application.

Furthermore, add a capacitor CC in parallel to the external resistance  $R_A$  in order to avoid output oscillations and other types of instability. (See Figure 11.)

Make sure that the capacitance value of CC is larger than the value given by the following equation:

$$CC[F] \geq 1 \div ( 2 \times \pi \times RA[\Omega] \times 6000 )$$

- **SII is equipped with a tool that allows you to calculate the necessary resistance values of the external resistances ( $R_A$ ,  $R_B$ ) automatically. SII will be pleased to assist its customers with their design work. Should such assistance be desired, please inquire at:**

**SII Components Sales Dept. Telephone: 043-211-1193 (Direct) Fax: 043-211-8032**

■ Characteristics of Major Items (All data represent typical values)

1. Input Voltage (VIN) - Output Voltage (VOU) Characteristics

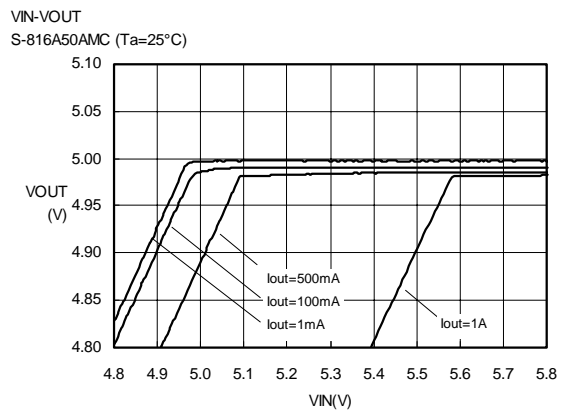
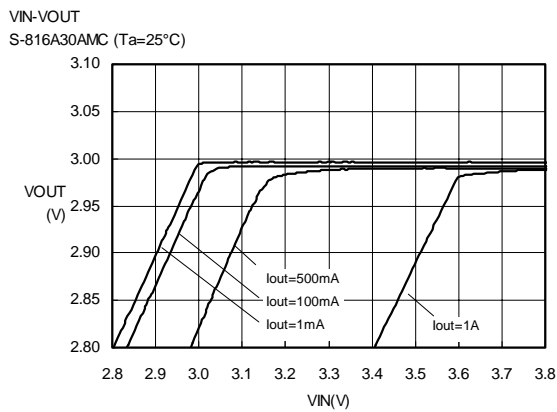
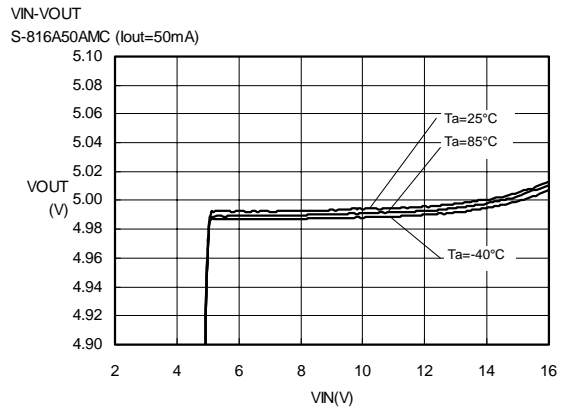
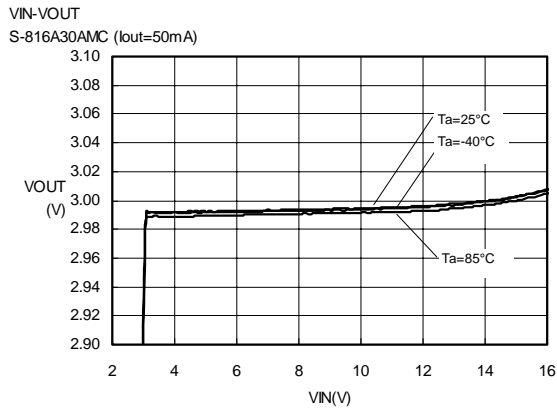

2. Output Current (IOUT) - Output Voltage (VOU) Characteristics

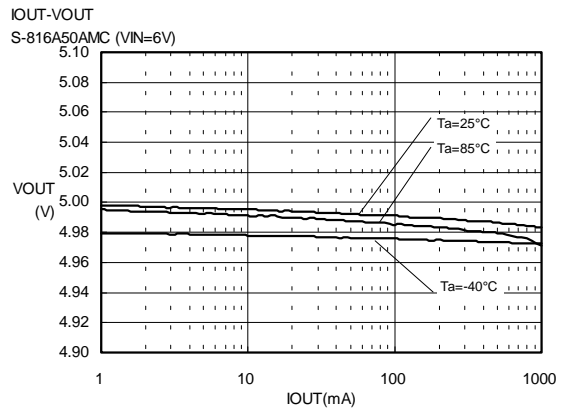
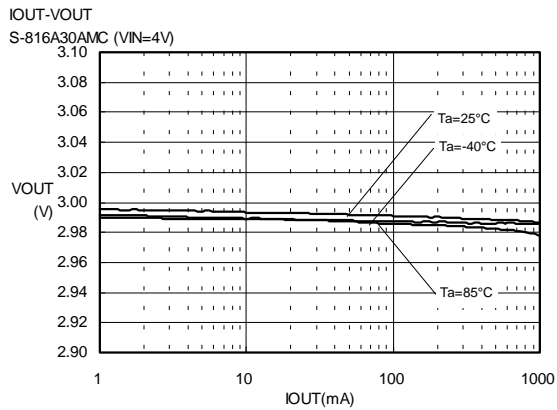

3. Temperature (Ta) - Output Voltage (VOU) Characteristics

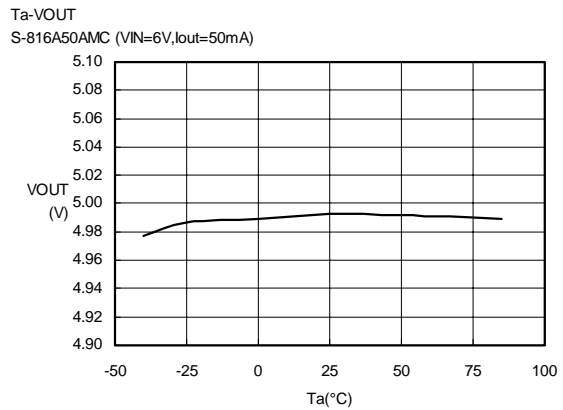
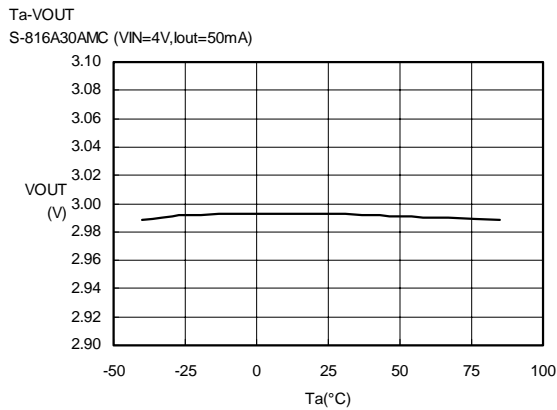

4. Input Voltage (VIN) - Consumption Current (ISS) Characteristics

5. Input Voltage (VIN) - EXT Output Sink Overcurrent Set Value (Imax) Characteristics

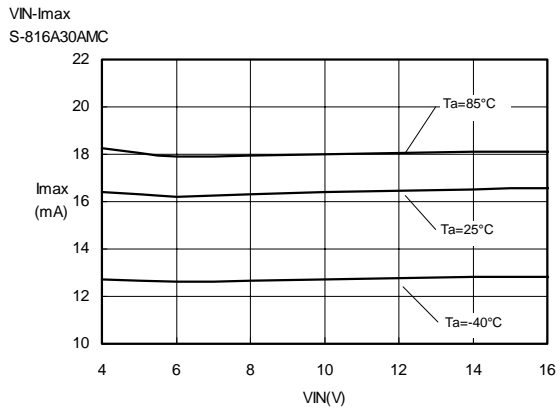
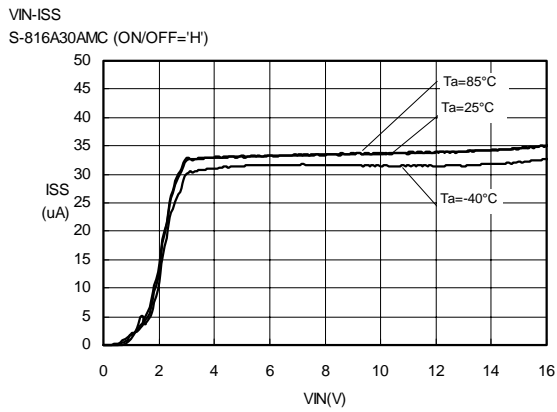

6. Input Voltage (VIN) - Power-Off Terminal Input Voltage (VSH, VSL) Characteristics

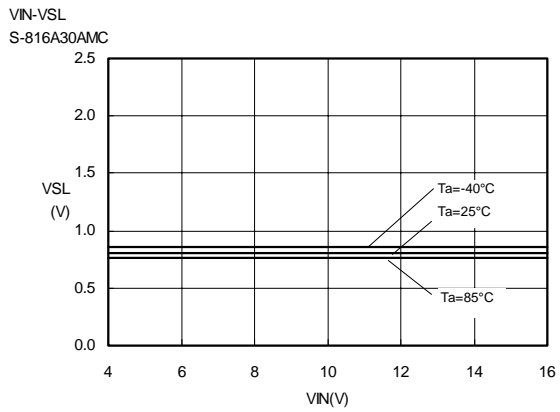
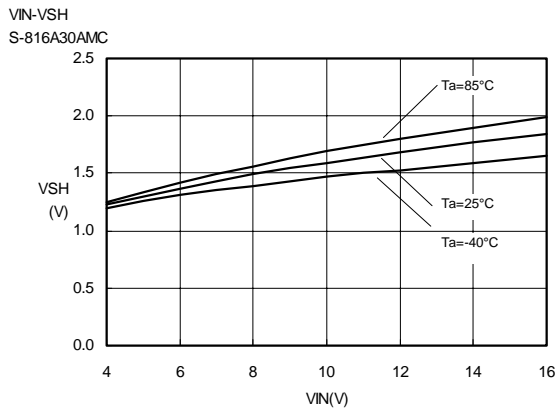

■ Transient Response Characteristics (All data represent typical values)

1. Input Transient Response Characteristics (Power-on VIN:0V→VOUT+1V IOU:0A CL:10uF)

S-816A30AMC (VIN:0V 4V)

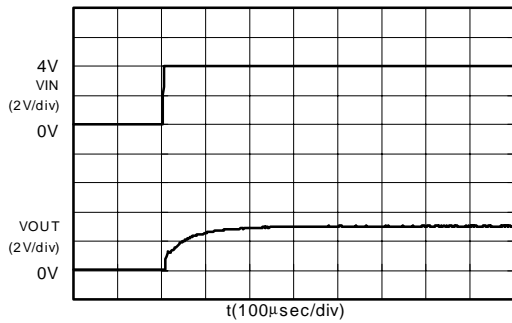

S-816A50AMC (VIN:0V 6V)

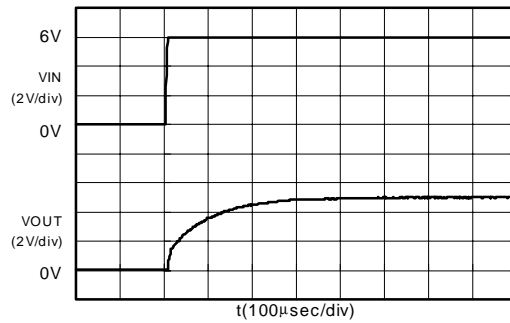

S-816A30AMC (Iout:10mA)

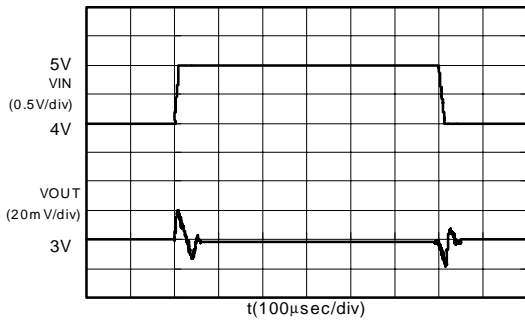

S-816A30AMC (Iout:300mA)

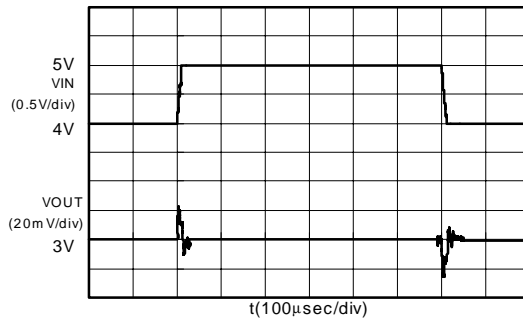

2. Input Transient Response Characteristics (Supply voltage variation VIN:VOUT+1V↔VOUT+2V CL:10uF)

S-816A50AMC (Iout:10mA)

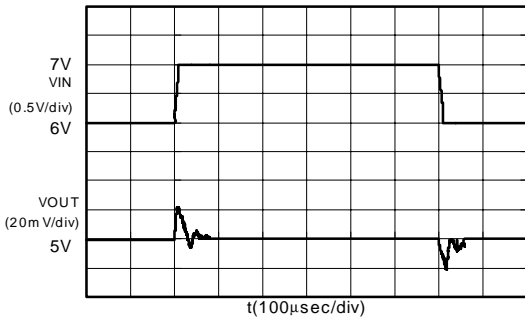

S-816A50AMC (Iout:300mA)

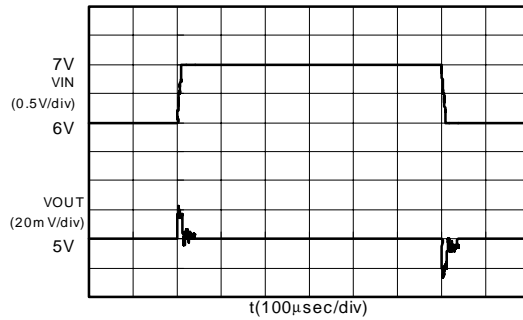

3. Load Transient Response Characteristics ( IOU:1mA ↔100mA CL:10uF)

S-816A30AMC (VIN:4V)

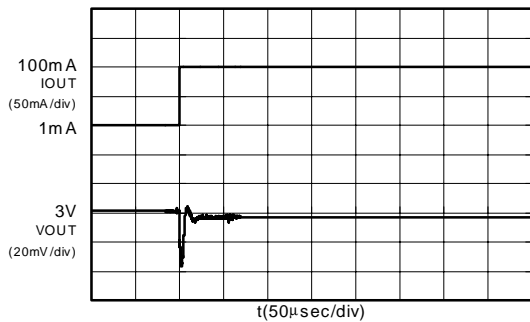

S-816A30AMC (VIN:4V)

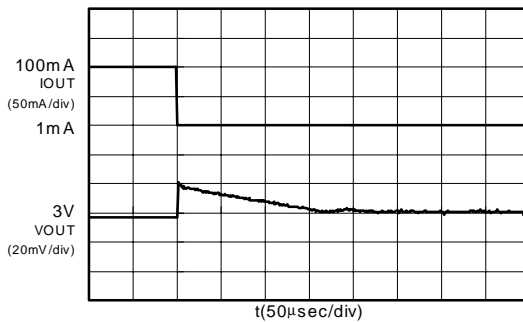

S-816A50AMC (VIN:6V)

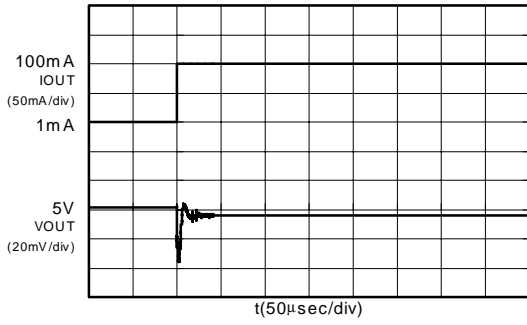

S-816A50AMC (VIN:6V)

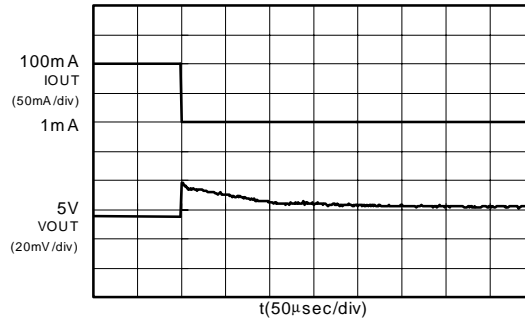

4. Power-Off Terminal Transient Response Characteristics (ON/OFF terminal : 0V→VIN IOUT:0A CL:10uF)

S-816A30AMC (VIN:4V)

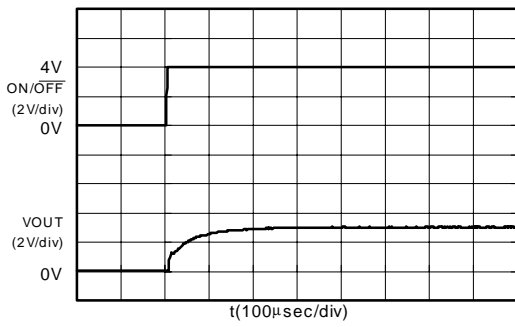

S-816A50AMC (VIN:6V)

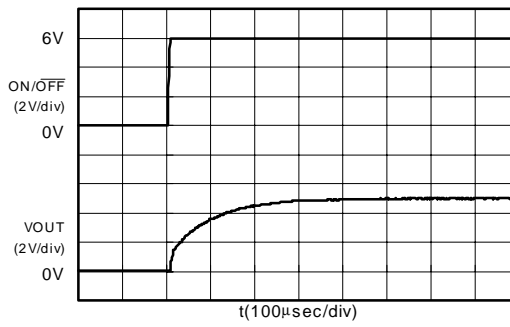

● Dimensions 外形図

Unit : mm

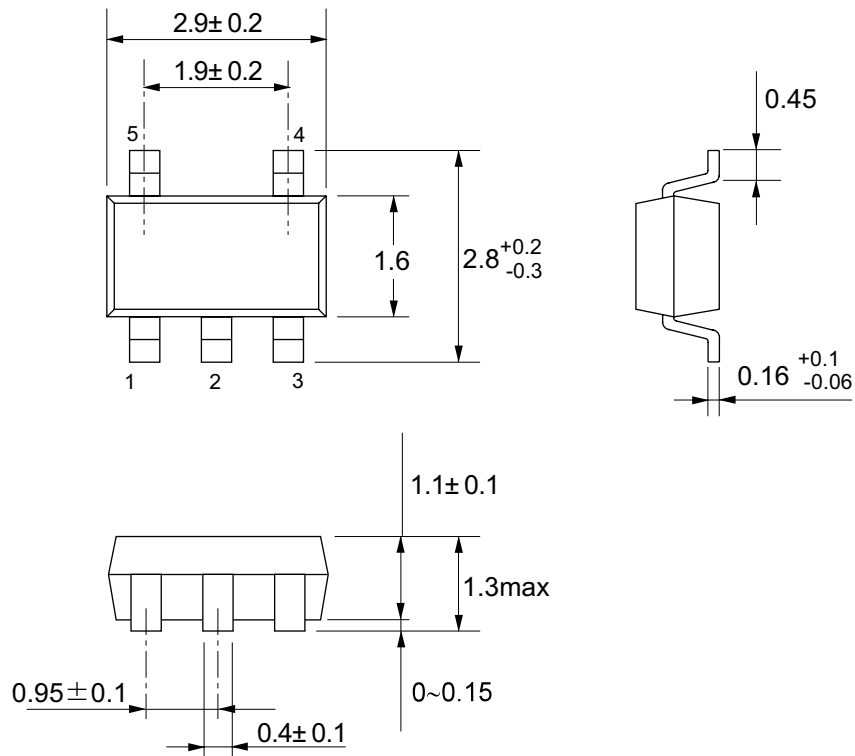

No. : MP005-A-P-SD-1.1

● Taping Specifications テーピング図

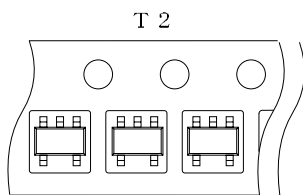
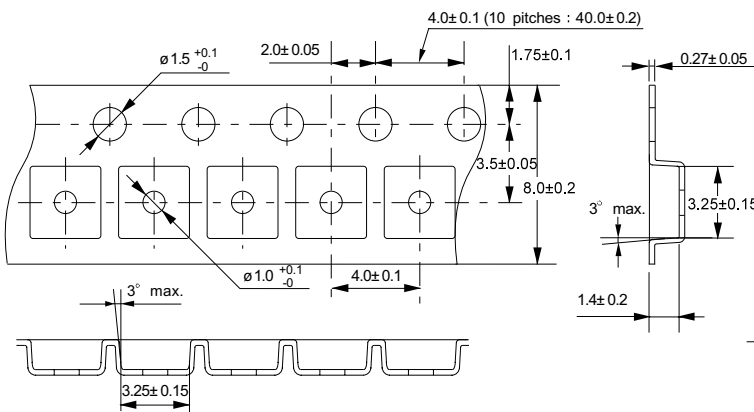

Feed direction  
引き出し方向

No. : MP005-A-C-SD-1.0

● Reel Specifications リール図

3000 pcs./reel

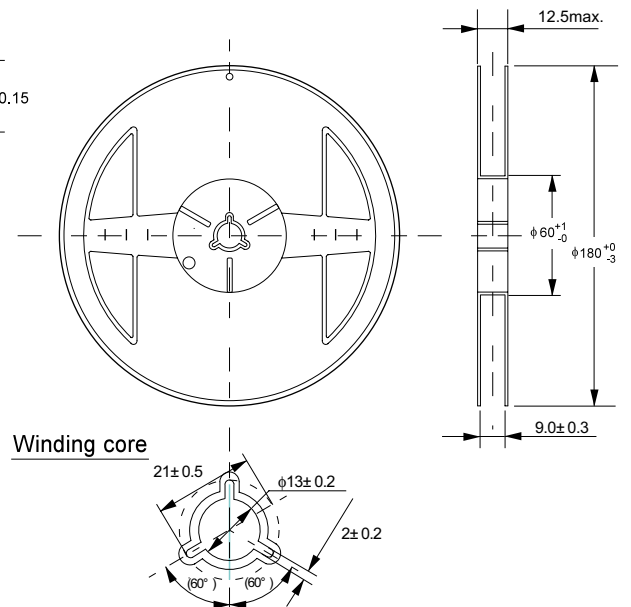

Winding core

No. : MP005-A-R-SD-1.0

● SOT-23-5

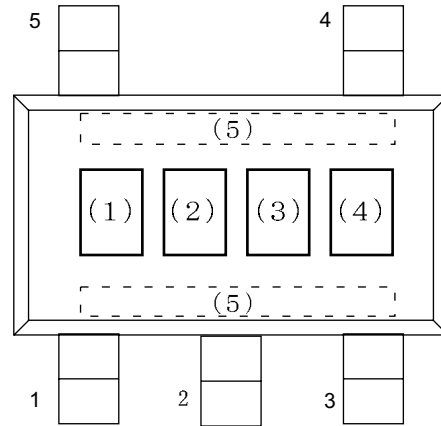

(1) to (3) : Product name (abbreviation)

(4) : Month of assembly

(5) : Dot on one side (Year and week of assembly)

No. : MP 0 0 5 - A - M - S 1 - 1 . 0



- The information described herein is subject to change without notice.
- Seiko Instruments Inc. is not responsible for any problems caused by circuits or diagrams described herein whose related industrial properties, patents, or other rights belong to third parties. The application circuit examples explain typical applications of the products, and do not guarantee the success of any specific mass-production design.
- When the products described herein are regulated products subject to the Wassenaar Arrangement or other agreements, they may not be exported without authorization from the appropriate governmental authority.
- Use of the information described herein for other purposes and/or reproduction or copying without the express permission of Seiko Instruments Inc. is strictly prohibited.
- The products described herein cannot be used as part of any device or equipment affecting the human body, such as exercise equipment, medical equipment, security systems, gas equipment, or any apparatus installed in airplanes and other vehicles, without prior written permission of Seiko Instruments Inc.
- Although Seiko Instruments Inc. exerts the greatest possible effort to ensure high quality and reliability, the failure or malfunction of semiconductor products may occur. The user of these products should therefore give thorough consideration to safety design, including redundancy, fire-prevention measures, and malfunction prevention, to prevent any accidents, fires, or community damage that may ensue.