

---



---

## LOW DROPOUT CMOS VOLTAGE REGULATOR      S-814 Series

---



---

The S-814 Series is a low dropout voltage, high output voltage accuracy and low current consumption positive voltage regulator developed utilizing CMOS technology.

Built-in low ON-resistance transistors provide low dropout voltage and large output current.

A power-OFF circuit ensures long battery life.

Various types of output capacitors can be used in the S-814 Series compared with the past CMOS voltage regulators.

(i.e., small ceramic capacitors can also be used in the S-814 Series).

The SOT-23-5 miniaturized package and the SOT-89-5 package are recommended to be used for configuring portable devices and large output current applications, respectively.

### ■ Features

- Low current consumption
  - During operation: Typ. 30  $\mu$ A, Max. 40  $\mu$ A
  - During power off: Typ. 100 nA, Max. 500 nA
- Output voltage: 0.1 V steps between 2.0 and 6.0 V
- High accuracy output voltage:  $\pm 2.0\%$
- Output current;
  - 110 mA capable (3.0 V output product,  $V_{IN}=4$  V) <sup>Note\*</sup>
  - 180 mA capable (5.0 V output product,  $V_{IN}=6$  V) <sup>Note\*</sup>
- Low dropout voltage
  - Typ. 170 mV (5.0 V output product,  $I_{OUT} = 60$  mA)
- Built-in power-off circuit
- Built-in short current limit circuit
- Low ESR capacitor (e.g., a ceramic capacitor of 0.47  $\mu$ F or more) can be used as the output capacitor.
- Compact package: SOT-23-5, SOT-89-5

Note\*

Check power dissipation of the package when you use large output current.

### ■ Applications

- Power source for battery-powered devices
- Power source for personal communication devices
- Power source for home electric/electronic appliances

■ Block Diagram

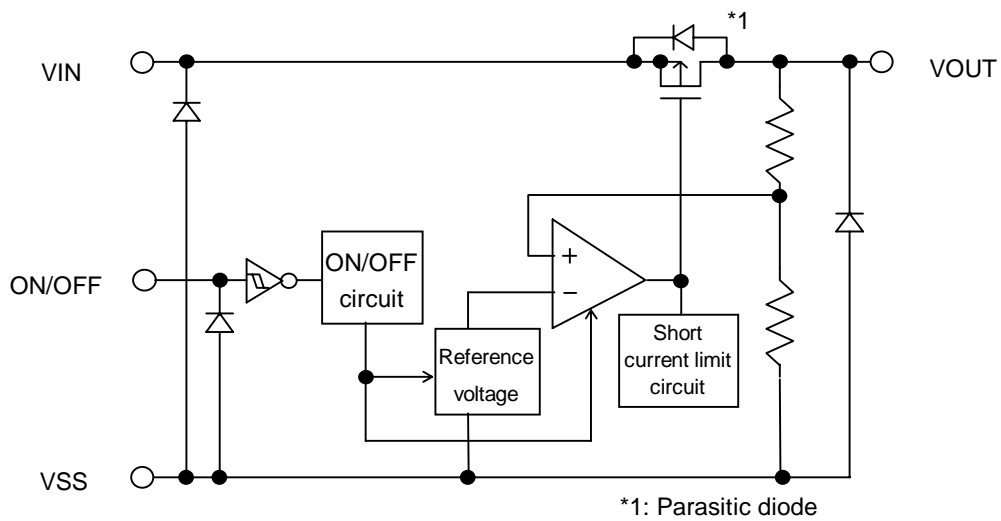

Figure 1 Block Diagram

■ Selection Guide

1. Product Name

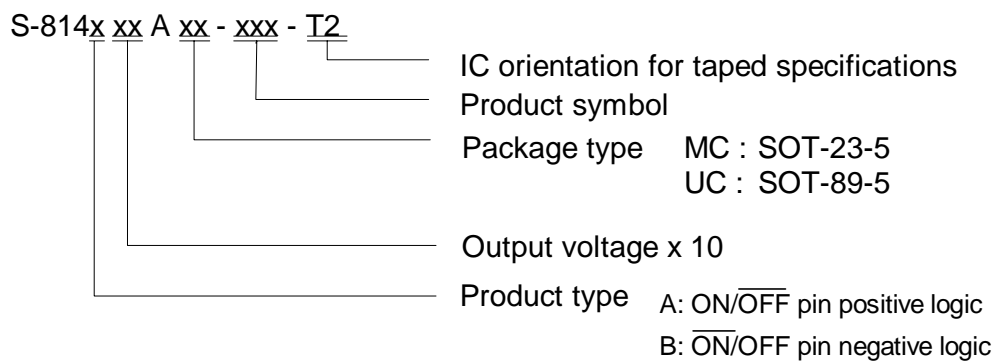

Table 1 Selection Guide

Output Voltage	SOT-23-5	SOT-89-5
2.0 V ± 2.0%	S-814A20AMC-BCK-T2	S-814A20AUC-BCK-T2
2.2 V ± 2.0%	—	S-814A22AUC-BCM-T2
2.4 V ± 2.0%	—	S-814A24AUC-BCO-T2
2.5 V ± 2.0%	S-814A25AMC-BCP-T2	S-814A25AUC-BCP-T2
2.7 V ± 2.0%	S-814A27AMC-BCR-T2	—
2.8 V ± 2.0%	S-814A28AMC-BCS-T2	S-814A28AUC-BCS-T2
3.0 V ± 2.0%	S-814A30AMC-BCU-T2	S-814A30AUC-BCU-T2
3.3 V ± 2.0%	S-814A33AMC-BCX-T2	S-814A33AUC-BCX-T2
3.8 V ± 2.0%	S-814A38AMC-BDC-T2	S-814A38AUC-BDC-T2
4.0 V ± 2.0%	S-814A40AMC-BDE-T2	S-814A40AUC-BDE-T2
5.0 V ± 2.0%	S-814A50AMC-BDO-T2	S-814A50AUC-BDO-T2

Note:

Contact our sales person for products with an output voltage other than those specified above or product type B.

■ Pin Configuration

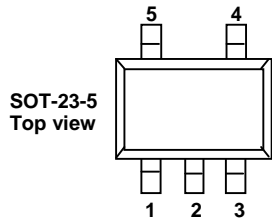

Figure 2 SOT-23-5

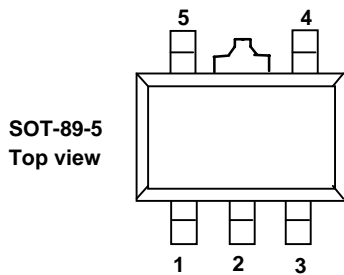

Figure 3 SOT-89-5

Table 2-1 Pin Assignment (1)

Pin No.	Symbol	Description
1	VIN	Voltage input pin
2	VSS	GND pin
3	ON/OFF	Power off pin
4	NC <sup>Note*</sup>	No connection
5	VOUT	Voltage output pin

Table 2-2 Pin Assignment (2)

Pin No.	Symbol	Description
1	VOUT	Voltage output pin
2	VSS	GND pin
3	NC <sup>Note*</sup>	No connection
4	ON/OFF	Power off pin
5	VIN	Voltage input pin

Note\*: Electrically open - - there is no problem even when connecting pin NC to VIN or VSS.

■ Absolute Maximum Ratings

Table 3 Absolute Maximum Ratings (25°C unless otherwise specified)

Item	Symbol	Absolute Maximum Rating	Unit
Input voltage	VIN	12	V
	VON / OFF	VSS-0.3 to 12	V
Output voltage	VOUT	VSS-0.3 to VIN+0.3	V
Power dissipation	PD	250 (SOT-23-5) 500 (SOT-89-5)	mW
Operating temperature range	Tope	-40 to +85	°C
Storage temperature range	Tstg	-40 to +125	°C

Note:

This IC has a protection circuit against static electricity. DO NOT apply high static electricity or high voltage that exceeds the performance of the protection circuit to the IC.

■ Electrical Characteristics

S-814AXXAMC/UC, S-814BXXAMC/UC

Table 4 Electrical Characteristics

(25°C unless otherwise specified)

Item	Symbol	Conditions	Min.	Typ.	Max.	Units	Test circuits	
Output voltage *1)	$V_{OUT(E)}$	$V_{IN}=V_{OUT(S)}+1V, I_{OUT}=30mA$	$V_{OUT(S)} \times 0.98$	$V_{OUT(S)}$	$V_{OUT(S)} \times 1.02$	V	1	
Output current *2)	$I_{OUT}$	$V_{OUT(S)}+1V \leq V_{IN} \leq 10V$	$2.0V \leq V_{OUT(S)} \leq 2.9V$	100 *5)	—	—	mA	3
			$3.0V \leq V_{OUT(S)} \leq 3.9V$	110 *5)	—	—	mA	3
			$4.0V \leq V_{OUT(S)} \leq 4.9V$	135 *5)	—	—	mA	3
			$5.0V \leq V_{OUT(S)} \leq 6.0V$	180 *5)	—	—	mA	3
Dropout voltage *3)	$V_{drop}$	$I_{OUT} = 60mA$	$2.0V \leq V_{OUT(S)} \leq 2.4V$	—	0.51	0.87	V	1
			$2.5V \leq V_{OUT(S)} \leq 2.9V$	—	0.38	0.61	V	1
			$3.0V \leq V_{OUT(S)} \leq 3.4V$	—	0.30	0.44	V	1
			$3.5V \leq V_{OUT(S)} \leq 3.9V$	—	0.24	0.33	V	1
			$4.0V \leq V_{OUT(S)} \leq 4.4V$	—	0.20	0.26	V	1
			$4.5V \leq V_{OUT(S)} \leq 4.9V$	—	0.18	0.22	V	1
			$5.0V \leq V_{OUT(S)} \leq 5.4V$	—	0.17	0.21	V	1
		$5.5V \leq V_{OUT(S)} \leq 6.0V$	—	0.17	0.20	V	1	
Line regulation 1	$\frac{\Delta V_{OUT1}}{\Delta V_{IN} \cdot V_{OUT}}$	$V_{OUT(S)} + 0.5V \leq V_{IN} \leq 10V, I_{OUT} = 30mA$	—	0.05	0.2	%/V	1	
Line regulation 2	$\frac{\Delta V_{OUT2}}{\Delta V_{IN} \cdot V_{OUT}}$	$V_{OUT(S)} + 0.5V \leq V_{IN} \leq 10V, I_{OUT} = 10\mu A$	—	0.05	0.2	%/V	1	
Load regulation	$\Delta V_{OUT3}$	$V_{IN} = V_{OUT(S)} + 1V, 10\mu A \leq I_{OUT} \leq 80mA$	—	30	50	mV	1	
Output voltage temperature coefficient *4)	$\frac{\Delta V_{OUT}}{\Delta T_a \cdot V_{OUT}}$	$V_{IN} = V_{OUT(S)} + 1V, I_{OUT} = 30mA, -40^\circ C \leq T_a \leq 85^\circ C$	—	$\pm 100$	—	ppm/ $^\circ C$	1	
Current consumption during operation	$I_{SS1}$	$V_{IN} = V_{OUT(S)} + 1V, ON/OFF \text{ pin} = ON, \text{ no load}$	—	30	40	$\mu A$	2	
Current consumption when power off	$I_{SS2}$	$V_{IN} = V_{OUT(S)} + 1V, ON/OFF \text{ pin} = OFF, \text{ no load}$	—	0.1	0.5	$\mu A$	2	
Input voltage	$V_{IN}$		—	—	10	V	1	
Power-off pin input voltage "H"	$V_{SH}$	$V_{IN} = V_{OUT(S)} + 1V, R_L = 1k\Omega, \text{ Check it at } V_{OUT} \text{ level.}$	1.5	—	—	V	4	
Power-off pin input voltage "L"	$V_{SL}$	$V_{IN} = V_{OUT(S)} + 1V, R_L = 1k\Omega, \text{ Check it at } V_{OUT} \text{ level.}$	—	—	0.3	V	4	
Power-off pin input current "H"	$I_{SH}$	$V_{IN} = V_{OUT(S)} + 1V, ON/OFF = 7V$	—	—	0.1	$\mu A$	4	
Power-off pin input current "L"	$I_{SL}$	$V_{IN} = V_{OUT(S)} + 1V, ON/OFF = 0V$	—	—	-0.1	$\mu A$	4	
Short current limit	$I_{OS}$	$V_{IN} = V_{OUT(S)} + 1V, V_{OUT} \text{ pin} = 0V$	—	70	—	mA	3	
Ripple rejection	$ RR $	$V_{IN} = V_{OUT(S)} + 1V, f = 100Hz, \Delta V_{rip} = 0.5V_{rms}, I_{OUT}=30mA$	—	45	—	dB	5	

\*1)  $V_{OUT(S)}$ =Specified output voltage

$V_{OUT(E)}$ =Effective output voltage, i.e., the output voltage when fixing  $I_{OUT}(=30 \text{ mA})$  and inputting  $V_{OUT(S)}+1.0 \text{ V}$ .

\*2) Output amperage when output voltage goes below 95% of  $V_{OUT(E)}$  after gradually increasing output current.

\*3)  $V_{drop} = V_{IN1} - (V_{OUT(E)} \times 0.98)$

$V_{IN1}$  = Input voltage when output voltage falls 98% of  $V_{OUT(E)}$  after gradually decreasing input voltage.

\*4) A change in temperatures [mV/ $^\circ C$ ] is calculated using the following equation.

$$\frac{\Delta V_{OUT}}{\Delta T_a} [\text{mV}/^\circ\text{C}] = V_{OUT(S)}[\text{V}] \times \frac{\Delta V_{OUT}}{\Delta T_a \cdot V_{OUT}} [\text{ppm}/^\circ\text{C}] \div 1000$$

\*5) Use load amperage not exceeding this value.

■ Test Circuits

1.

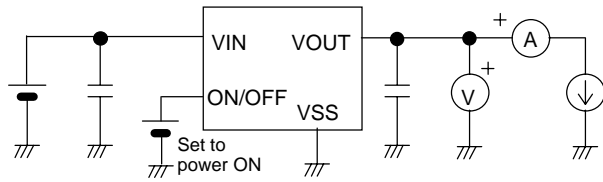

2.

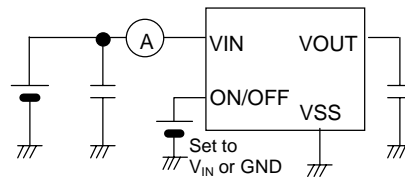

3.

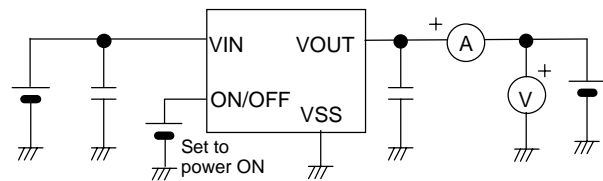

4.

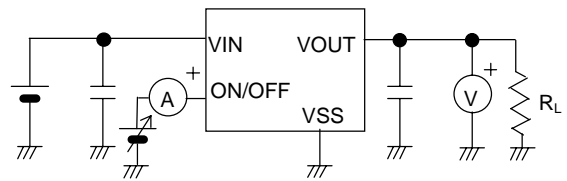

5.

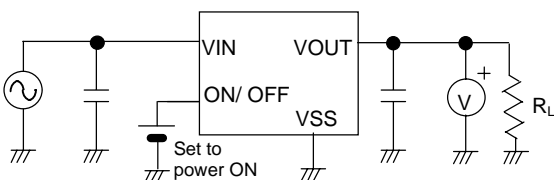
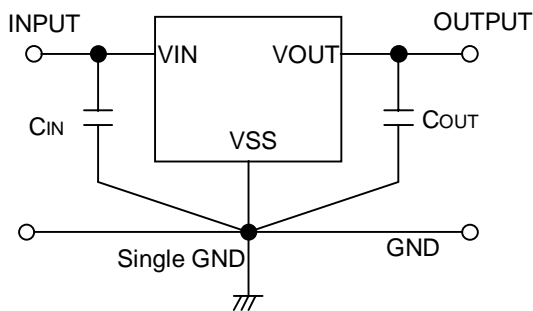

Figure 4 Test Circuits

■ Standard Circuit



In addition to a tantalum capacitor, a ceramic capacitor of 0.47  $\mu$ F or more can be used in CL. CIN is a capacitor used to stabilize input.

Figure 5 Standard Circuit

■ Technical Terms

1. Low dropout voltage regulator

The low dropout voltage regulator is a voltage regulator featuring a low dropout voltage characteristic due to its internal low ON-resistance characteristic transistors.

2. Low ESR

ESR is the abbreviation for Equivalent Series Resistance.

The low ESR output capacitor (CL) can be used in the S-814 Series.

3. Output voltage (V<sub>OUT</sub>)

The accuracy of the output voltage is ensured at ± 2.0% under the specified conditions of input voltage, output current, and temperature, which differ depending upon the product items.

Note:

If you change the above conditions, the output voltage value may vary out of the accuracy range of the output voltage. See the electrical characteristics and characteristics data for details.

4. Line regulations 1 and 2 (ΔV<sub>OUT1</sub>, ΔV<sub>OUT2</sub>)

Indicate the input voltage dependencies of output voltage. That is, the values show how much the output voltage changes due to a change in the input voltage with the output current remained unchanged.

5. Load regulation (ΔV<sub>OUT3</sub>)

Indicates the output current dependencies of output voltage. That is, the values show how much the output voltage changes due to a change in the output current with the input voltage remained unchanged.

6. Dropout voltage (V<sub>drop</sub>)

Indicates a difference between input voltage (V<sub>IN1</sub>) and output voltage when output voltage falls by 98 % of V<sub>OUT</sub> (E) by gradually decreasing the input voltage.

$$V_{drop} = V_{IN1} - [V_{OUT}(E) \times 0.98]$$

7. Temperature coefficient of output voltage [ $\frac{\Delta V_{OUT}}{\Delta T_a \cdot V_{OUT}}$ ]

The shadowed area in Figure 6 is the range where V<sub>OUT</sub> varies in the operating temperature range when the temperature coefficient of the output voltage is ±100 ppm/°C.

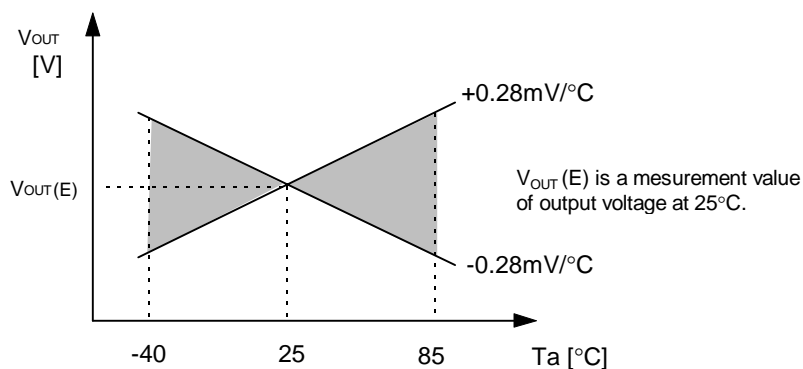

Figure 6 Typical Example of the S-814A28A

A change in temperatures of output voltage [mV/°C] is calculated using the following equation.

$$\frac{\Delta V_{OUT}}{\Delta T_a} [mV/°C] = V_{OUT}(S) [V] \times \frac{\Delta V_{OUT}}{\Delta T_a \cdot V_{OUT}} [ppm/°C] \div 1000$$

↑

Change in temperatures of output voltage

↑

Specified output voltage

↑

Output voltage temperature coefficient

■ Operation

1. Basic operation

Figure 7 shows the block diagram of the S-814 Series.

The error amplifier compares a reference voltage  $V_{REF}$  with part of the output voltage divided by the feedback resistors  $R_s$  and  $R_f$ . It supplies the output transistor with the gate voltage, necessary to ensure certain output voltage free of any fluctuations of input voltage and temperature.

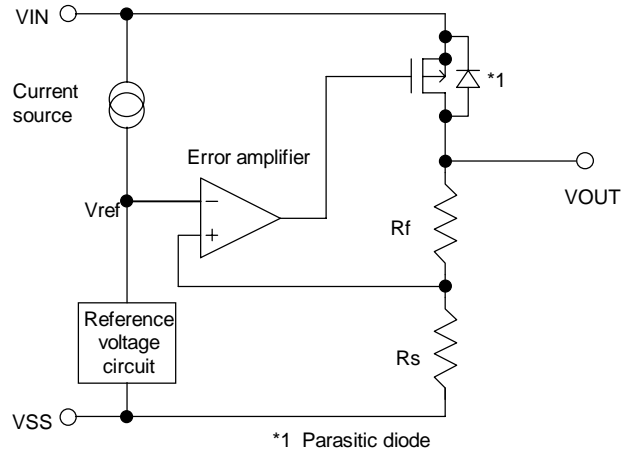

Figure 7 Typical Circuit Block Diagram

2. Output transistor

The S-814 Series uses a low on-resistance Pch MOS FET as the output transistor.

Be sure that VOUT does not exceed  $V_{IN}+0.3$  V to prevent the voltage regulator from being broken due to inverse current flowing from VOUT pin through a parasitic diode to VIN pin.

3. Power Off Pin (ON/OFF Pin)

This pin starts and stops the regulator.

When the ON/OFF pin is switched to the power off level, the operation of all internal circuits stops, the built-in Pch MOSFET output transistor between pins VIN and VOUT is switched off, allowing current consumption to be drastically reduced. The VOUT pin enters the Vss level due to internally divided resistance of several  $M\Omega$  between pins VOUT and VSS.

Furthermore, the structure of the ON/OFF pin is as shown in Figure 8. Since the ON/OFF pin is neither pulled down nor pulled up internally, do not use it in the floating state. In addition, please note that current consumption increases if a voltage of 0.3 V to  $V_{IN}-0.3$  V is applied to the ON/OFF pin. When the power off pin is not used, connect it to the VIN pin in case the product type is "A" and to the Vss pin in case of "B".

Product type	ON/OFF pin	Internal circuit	VOUT pin voltage	Current consumption
A	"H" : Power on	Operating	Set value	I <sub>ss1</sub>
A	"L" : Power off	Stop	V <sub>ss</sub> level	I <sub>ss2</sub>
B	"H" : Power off	Stop	V <sub>ss</sub> level	I <sub>ss2</sub>
B	"L" : Power on	Operating	Set value	I <sub>ss1</sub>

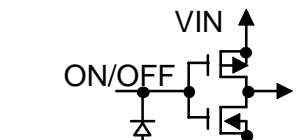

Figure 8 ON/OFF Pin

4. Short Current Limit Circuit

The S-814 Series incorporates a short current limit circuit to protect the output transistor against shortcircuiting between pins VOUT and VSS. The short current limit circuit controls output current as shown in (1) OUTPUT VOLTAGE versus OUTPUT CURRENT curve, and prevents output current of approx. 70 mA or more from flowing even if VOUT and VSS pins are shorted.

However, the short current limit circuit does not protect thermal shutdown.

Be sure that input voltage and load current do not exceed the specified power dissipation level.

When output current is large and a difference between input and output voltages is large even if not shorted, the short current limit circuit may start functioning and the output current may be controlled to the specified amperage.

For details, refer to (3) MAXIMUM OUTPUT CURRENT versus INPUT VOLTAGE curve (page 10).

### ■ Selection of Output Capacitor (CL)

Mount an output capacitor between VOUT and VSS pins for phase compensation.

The S-814 Series enables customers to use a ceramic capacitor as well as a tantalum or an aluminum electrolytic capacitor.

- A ceramic capacitor or an OS capacitor:  
Use a capacitor of 0.47  $\mu\text{F}$  or more.
- A tantalum or an aluminum electrolytic capacitor:  
Use a capacitor of 0.47  $\mu\text{F}$  or more and ESR of 10  $\Omega$  or less.  
Pay special attention not to cause an oscillation due to an increase in ESR at low temperatures, when you use the aluminum electrolytic capacitor.

Evaluate the capacitor taking into consideration its performance including temperature characteristics.

Overshoot and undershoot characteristics differ depending upon the type of the output capacitor you select.

Refer to "Output Capacitor Dependencies of Overshoot and Undershoot" in transient response characteristic examples (page 13).

### ■ Design Considerations

- Design wiring patterns for VIN, VOUT and GND pins to decrease impedance.  
When mounting the output capacitor, connect pins VOUT and VSS as close as possible.
- Note that output voltage may be increased at low load current (less than 10  $\mu\text{A}$ ).
- To prevent oscillation, it is recommended to use the external components under the following conditions.
  - \* Output capacitor (CL): 0.47  $\mu\text{F}$  or more
  - \* Equivalent Series Resistance (ESR): 10  $\Omega$  or less
  - \* Input series resistance (RIN): 10  $\Omega$  or less
- The voltage regulator may oscillate when power supply impedance is high and input capacitor is low or not connected.
- Be sure that input voltage and load current do not exceed the power dissipation level of the package.
- SII claims no responsibility for any and all disputes arising out of or in connection with any infringement of the products including this IC upon patents owned by a third party.
- Determine necessary output amperage, taking into consideration the minimum value of output current and Note \*5) of Table 4 "Electrical Characteristics" (page 4).



■ Typical Performance Curves

(1) OUTPUT VOLTAGE versus OUTPUT CURRENT (When load current increases)

S-814A20A(Ta=25°C)

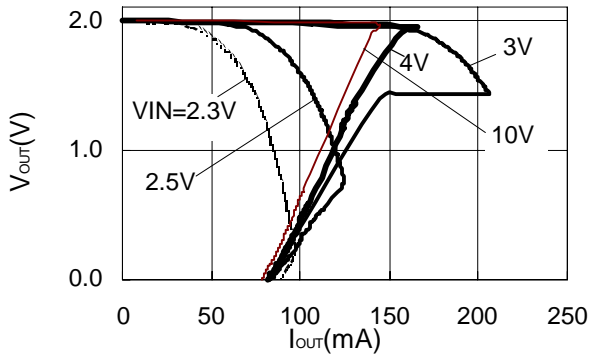

S-814A30A(Ta=25°C)

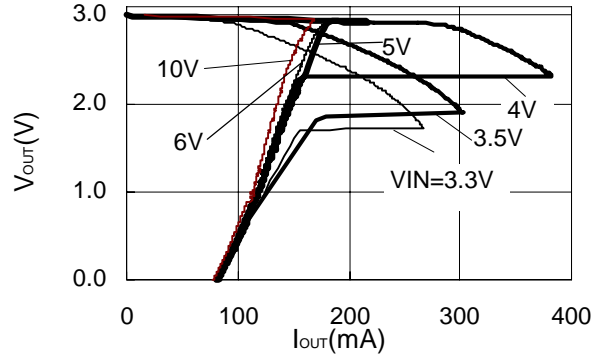

S-814A50A(Ta=25°C)

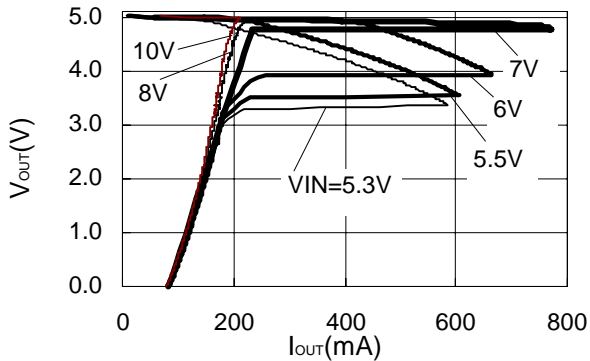

- \* Determine necessary output amperage, taking into consideration the following parameters:
- Minimum value of output current of Table 4 "Electrical Characteristics" and Note \*5) (page 4);
  - Power dissipation of the package

(2) OUTPUT VOLTAGE versus INPUT VOLTAGE

S-814A20A (Ta=25°C)

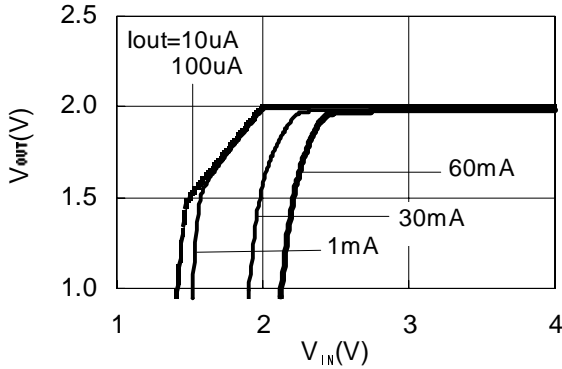

S-814A30A (Ta=25°C)

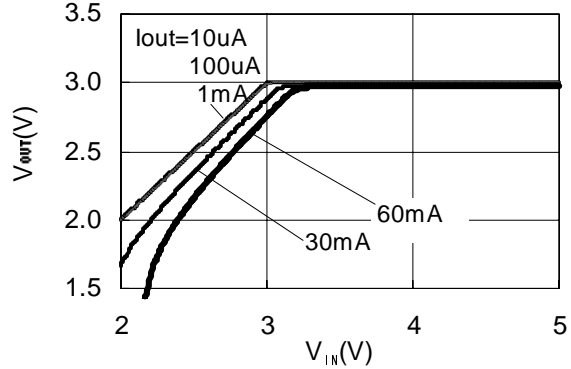

S-814A50A (Ta=25°C)

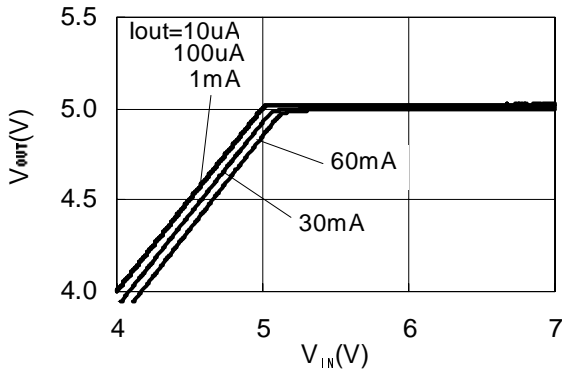

(3) MAXIMUM OUTPUT CURRENT versus INPUT VOLTAGE

S-814A20A

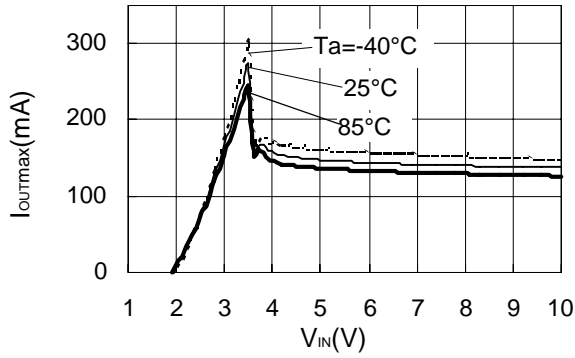

S-814A30A

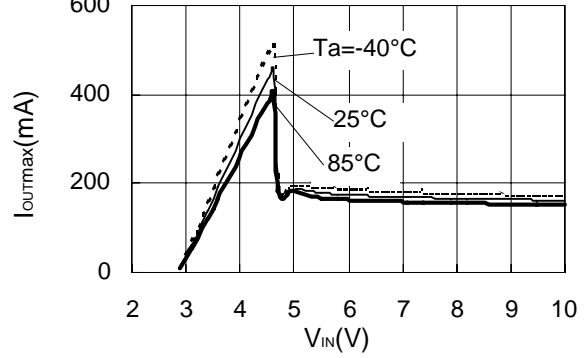

S-814A50A

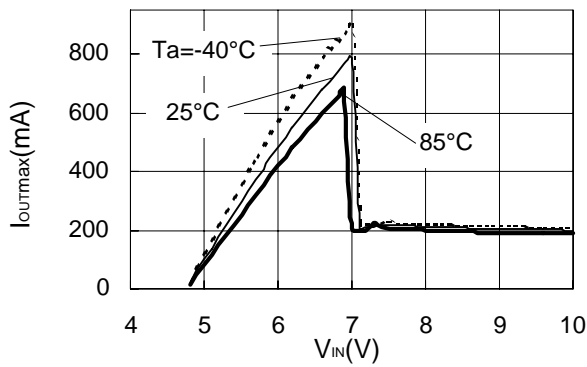

\* Determine necessary output amperage, taking into consideration the following parameters:

- Minimum value of output current of Table 4 "Electrical Characteristics" and Note \*5) (page 4);
- Power dissipation of the package

(4) OUTPUT CURRENT versus DROPOUT VOLTAGE

S-814A20A

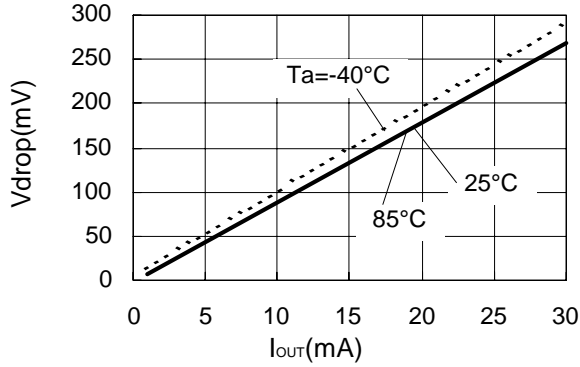

S-814A30A

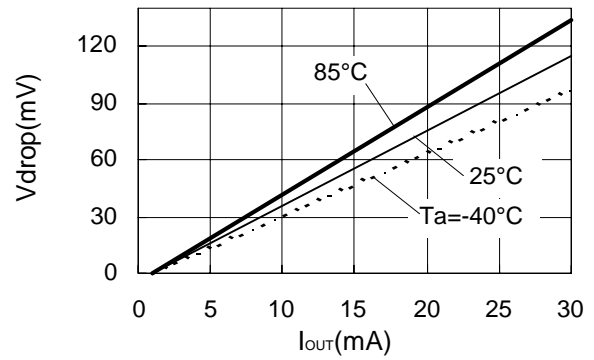

S-814A50A

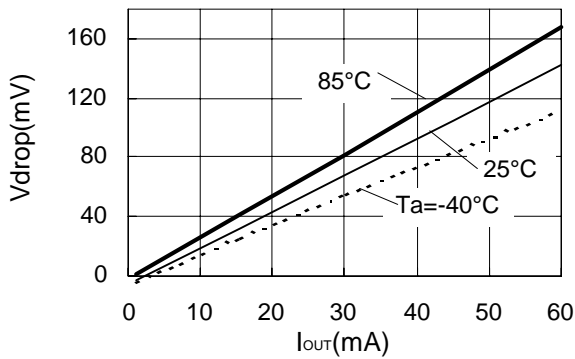

(5) OUTPUT VOLTAGE versus AMBIENT TEMPERATURE

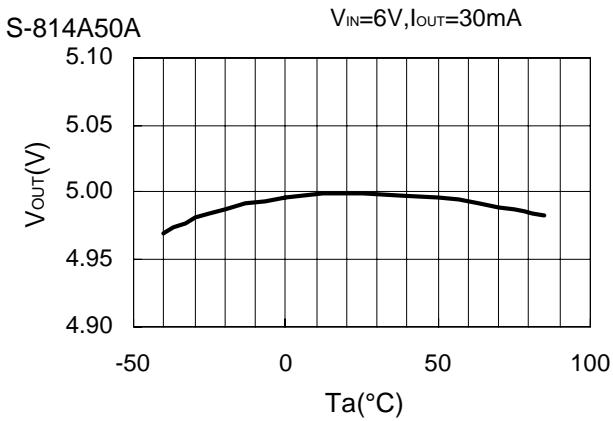
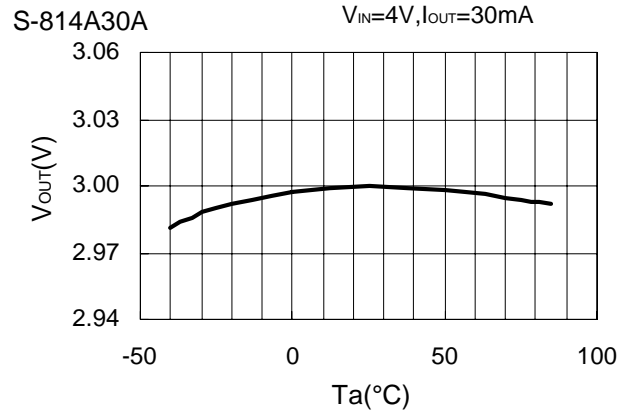
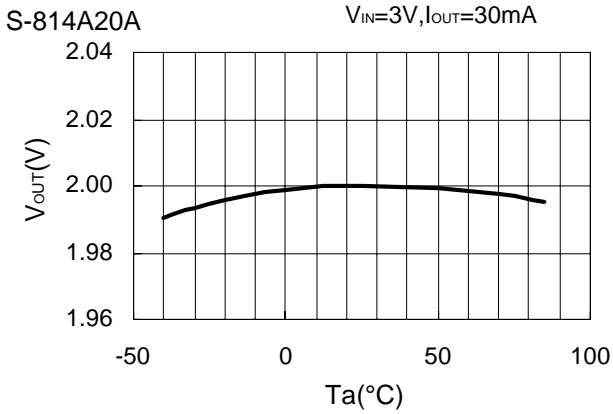

(6) LINE REGULATION versus AMBIENT TEMPERATURE

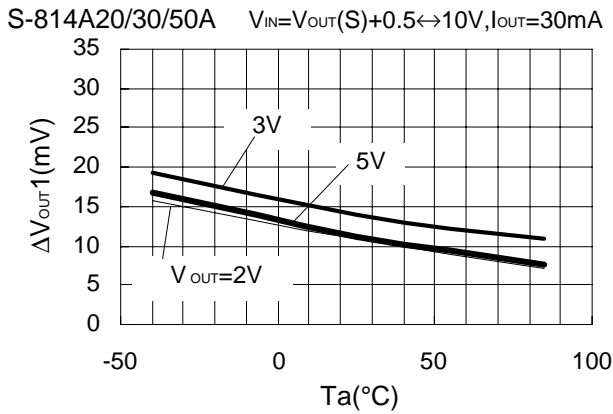

(7) LOAD REGULATION versus AMBIENT TEMPERATURE

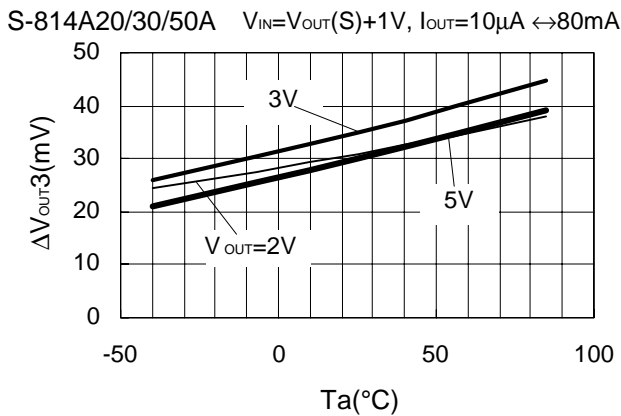

(8) CURRENT CONSUMPTION versus INPUT VOLTAGE

S-814A20A

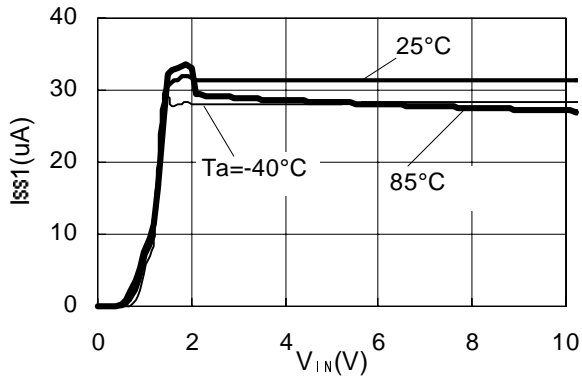

S-814A30A

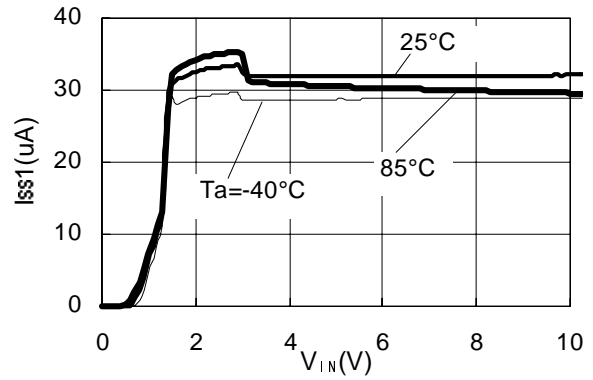

S-814A50A

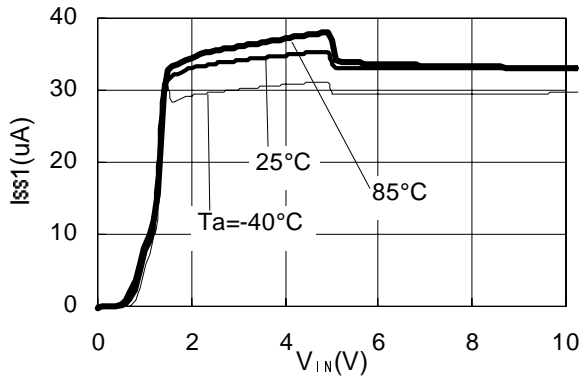

(9) THRESHOLD VOLTAGE OF POWER OFF PIN versus INPUT VOLTAGE

S-814A20A

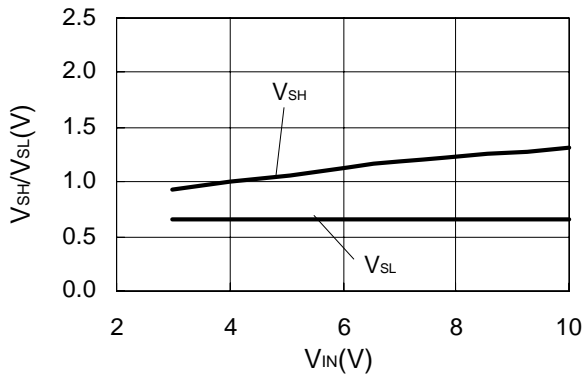

S-814A30A

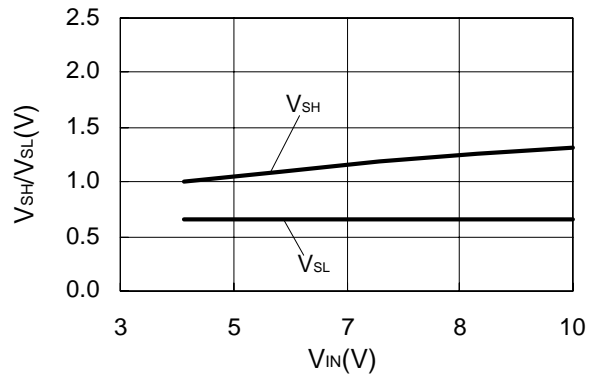

S-814A50A

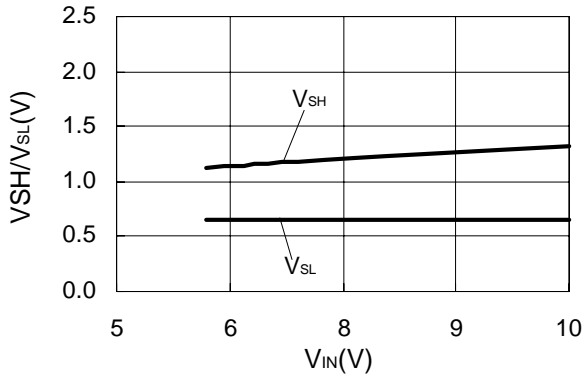

REFERENCE DATA

TRANSIENT RESPONSE CHARACTERISTICS (S-814A30A, Typical data: Ta=25°C)

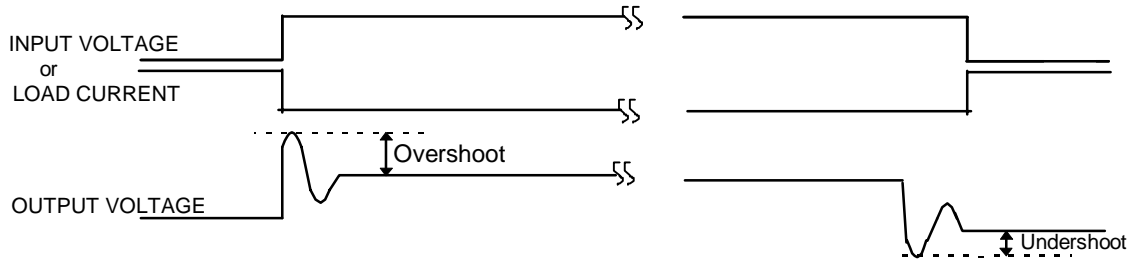

(1) At power on

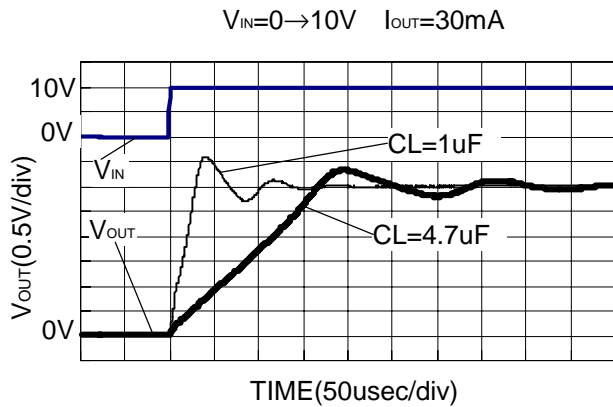

Load dependencies of overshoot

$V_{IN}=0 \rightarrow V_{OUT}(S)+1V$ ,  $CL=1\mu F$

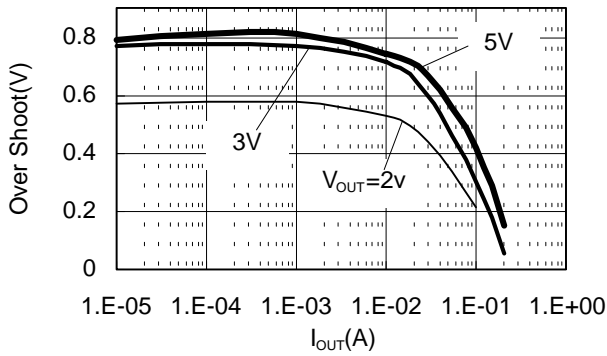

Output capacitor (CL) dependencies of overshoot

$V_{IN}=0 \rightarrow V_{OUT}(S)+1V$   $I_{OUT}=30mA$

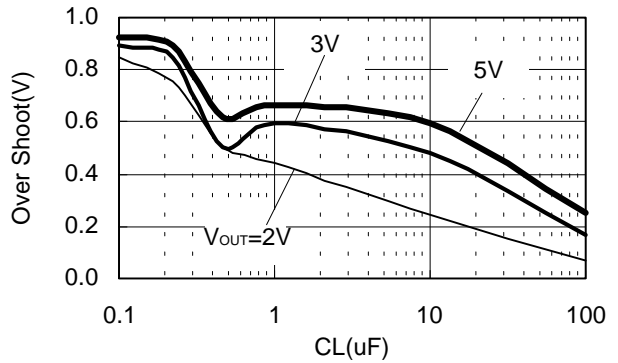

VDD dependencies of overshoot

$V_{IN}=0 \rightarrow VDD$ ,  $I_{OUT}=30mA$ ,  $CL=1\mu F$

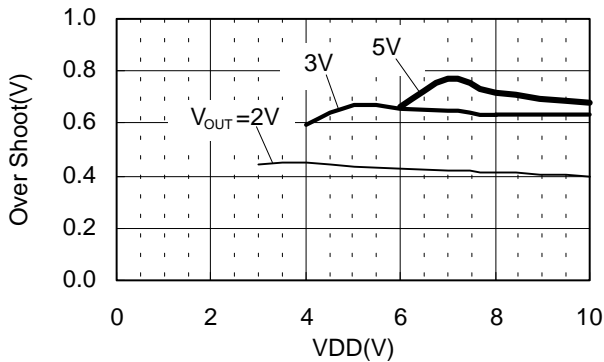

Temperature dependencies of overshoot

$V_{IN}=0 \rightarrow V_{OUT}(S)+1V$ ,  $I_{OUT}=30mA$ ,  $CL=1\mu F$

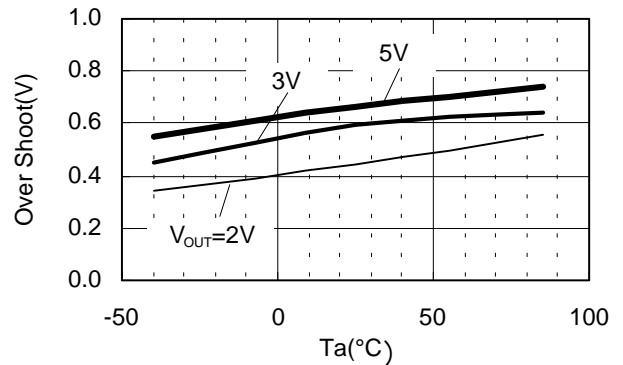

(2) At power on/off control by the power on/off pin

$V_{IN}=10V$  ON/OFF=0→10V  $I_{OUT}=30mA$

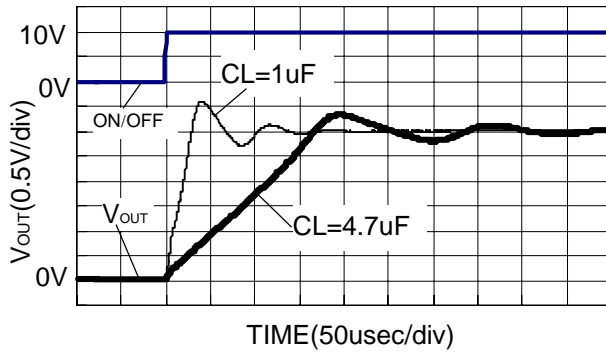

Load dependencies of overshoot

$V_{IN}=V_{OUT}(S)+1V, CL=1\mu F, ON/OFF=0 \rightarrow V_{OUT}(S)+1V$

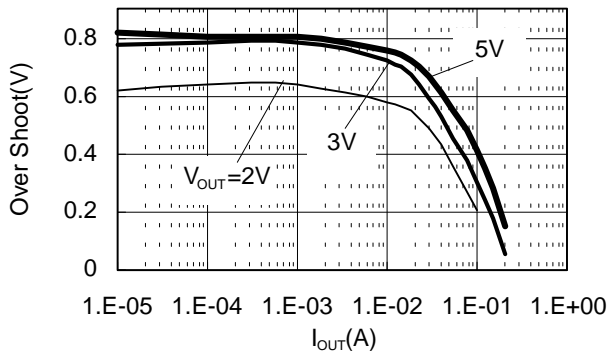

Output capacitor (CL) dependencies of overshoot

$V_{IN}=V_{OUT}(S)+1V, I_{OUT}=30mA, ON/OFF=0 \rightarrow V_{OUT}(S)+1V$

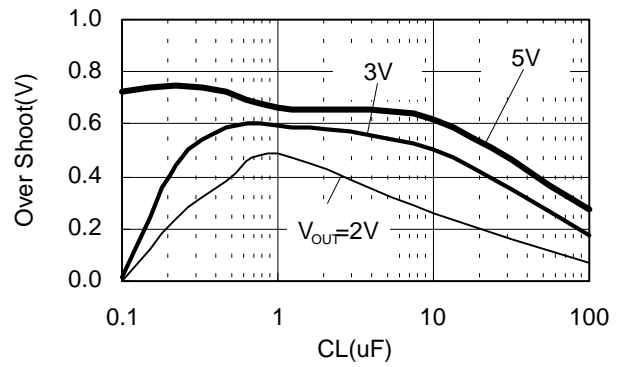

VDD dependencies of overshoot

$V_{IN}=VDD, I_{OUT}=30mA, CL=1\mu F, ON/OFF=0 \rightarrow VDD$

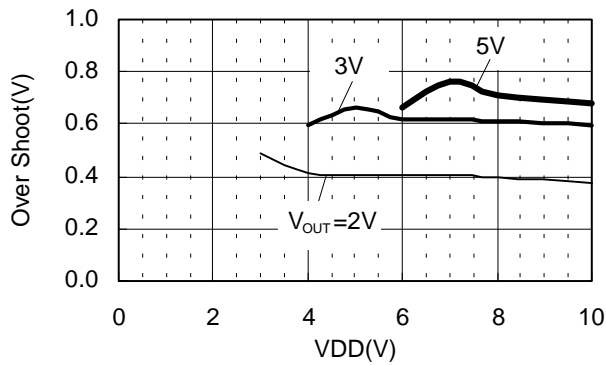

Temperature dependencies of overshoot

$V_{IN}=V_{OUT}(S)+1V, I_{OUT}=30mA, CL=1\mu F, ON/OFF=0 \rightarrow V_{OUT}(S)+1V$

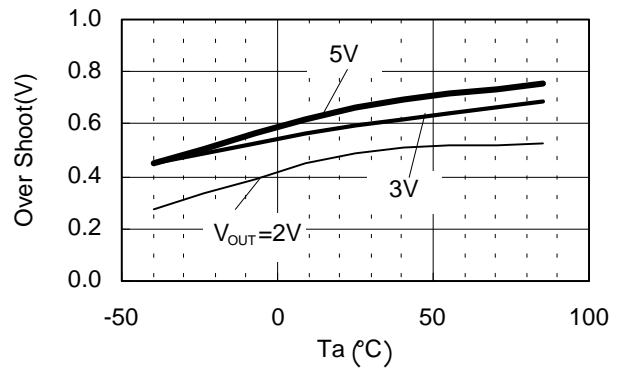

(3) At power fluctuation

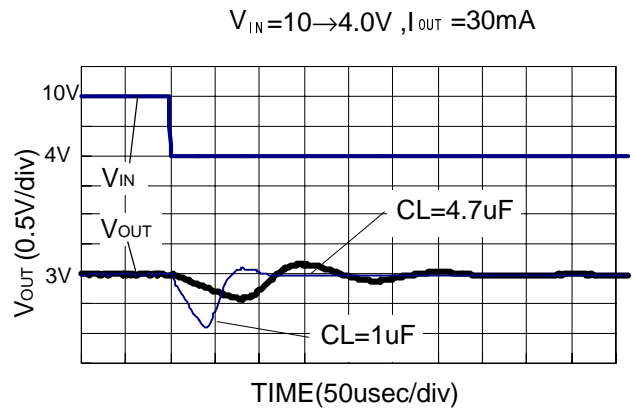
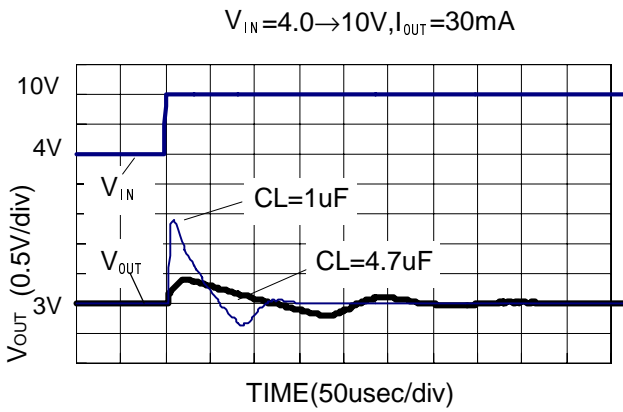

Load dependencies of overshoot

$V_{IN}=V_{OUT}(S)+1V \rightarrow V_{OUT}(S)+2V, CL=1\mu F$

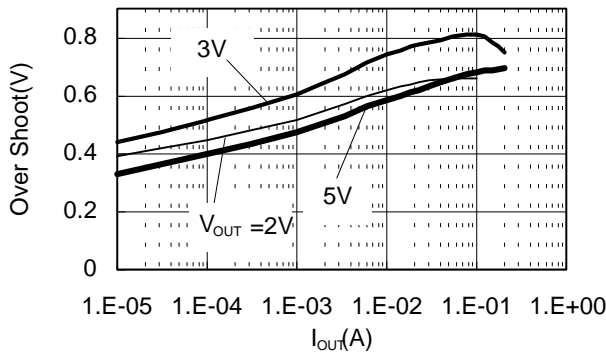

Output capacitor (CL) dependencies of overshoot

$V_{IN}=V_{OUT}(S)+1V \rightarrow V_{OUT}(S)+2V, I_{OUT}=30mA$

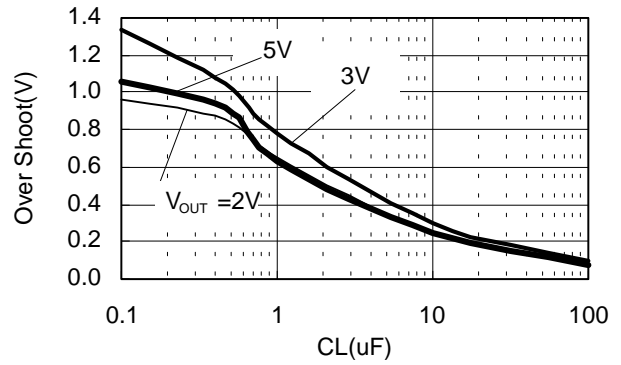

VDD dependencies of overshoot

$V_{IN}=V_{OUT}(S)+1V \rightarrow VDD, I_{OU}=30mA, CL=1\mu F$

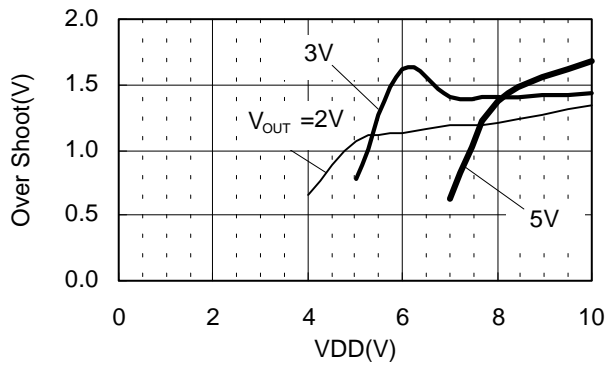

Temperature dependencies of overshoot

$V_{IN}=V_{OUT}(S)+1V \rightarrow V_{OUT}(S)+2V, I_{OUT}=30mA, CL=1\mu F$

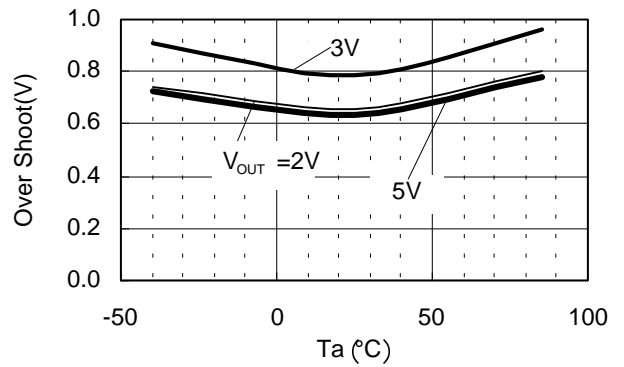

Load dependencies of undershoot

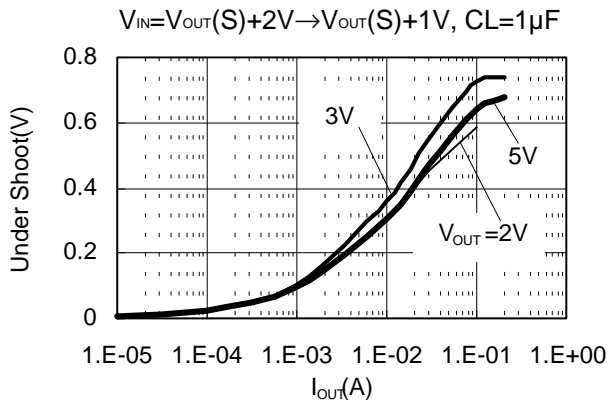

Output capacitor (CL) dependencies of undershoot

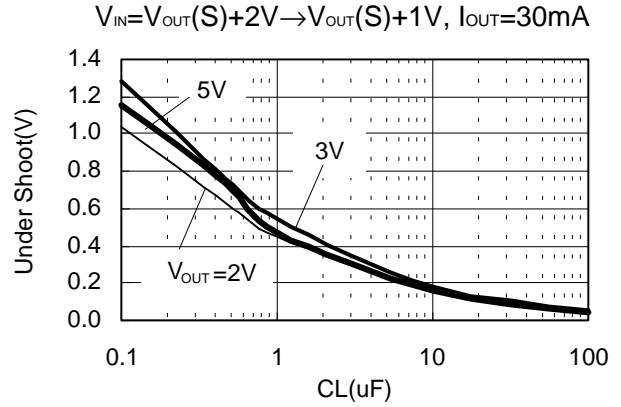

VDD dependencies of undershoot

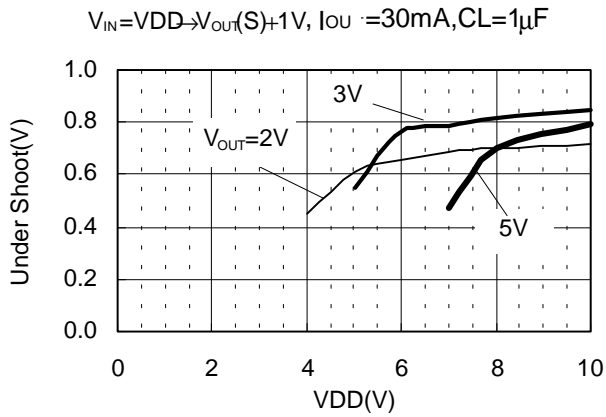

Temperature dependencies of undershoot

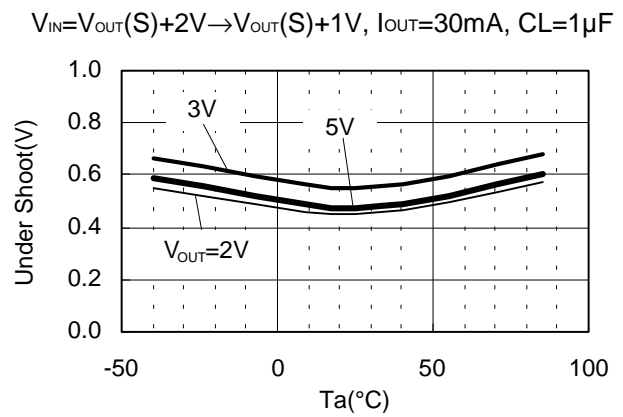



(4) At load fluctuation

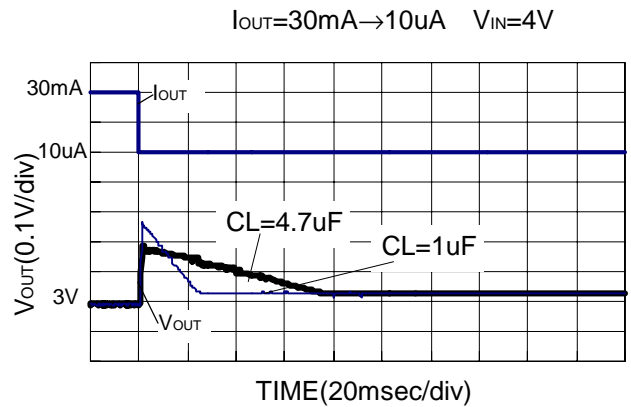
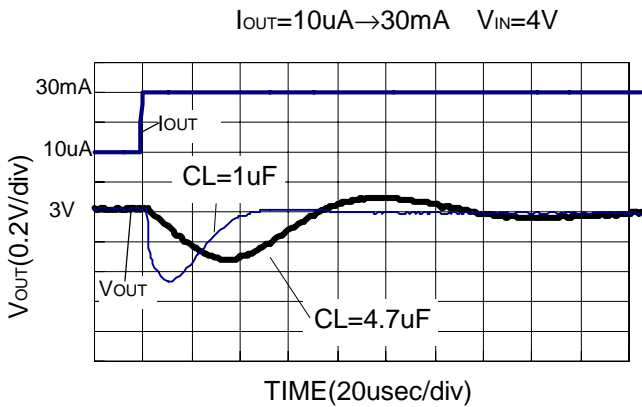

**Load current dependencies of overshoot**  
 $\Delta I_{OUT}$  shows larger load current at load current fluctuation. Smaller current at load current fluctuation is fixed to 10  $\mu A$ .  
 (i.e.)  
 $\Delta I_{OUT}=1.E-02$  (A) means load current fluctuation from 10 mA to 10  $\mu A$

**Output capacitor (CL) dependencies of overshoot**  
 $V_{IN}=V_{OUT}(S)+1V$ ,  $I_{OUT}=30mA \rightarrow 10\mu A$

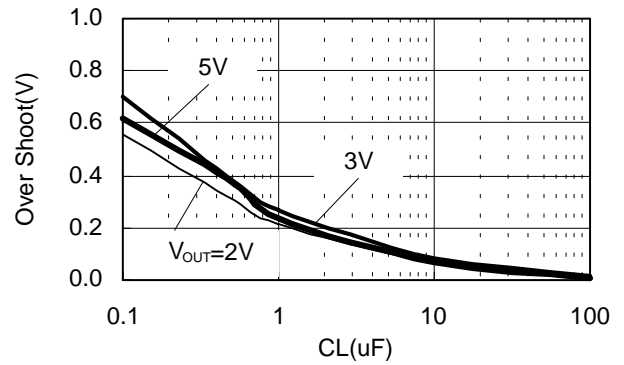
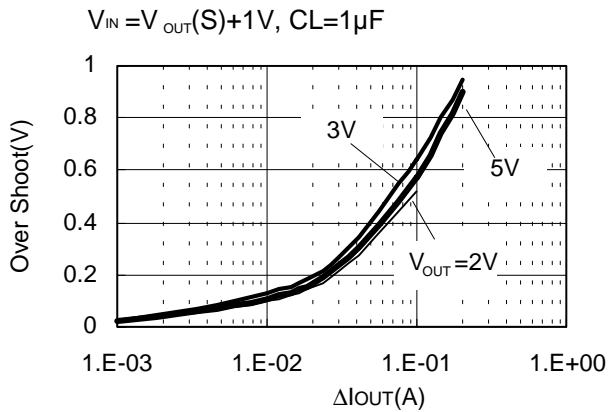

**VDD dependencies of overshoot**  
 $V_{IN}=VDD$ ,  $I_{OUT}=30mA \rightarrow 10\mu A$ ,  $CL=1\mu F$

**Temperature dependencies of overshoot**  
 $V_{IN}=V_{OUT}(S)+1V$ ,  $I_{OUT}=30mA \rightarrow 10\mu A$ ,  $CL=1\mu F$

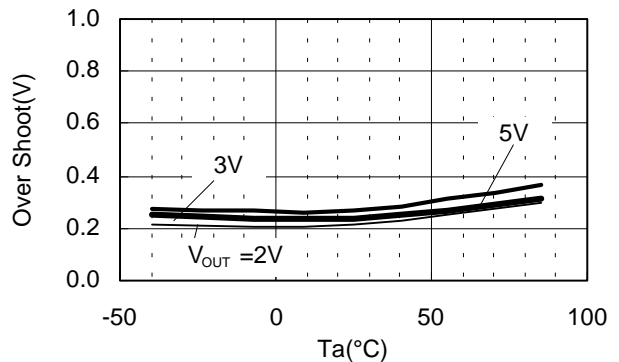
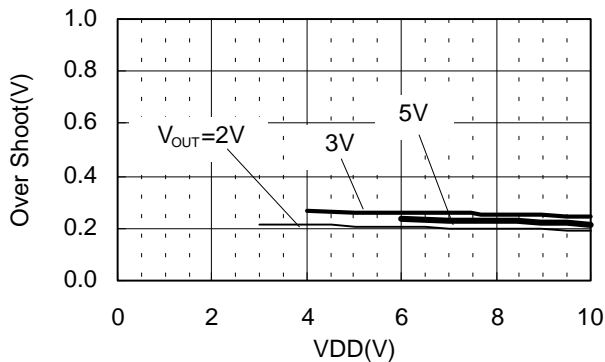

Load current dependencies of undershoot

$\Delta I_{OUT}$  shows larger load current at load current fluctuation. Lower current at load current fluctuation is fixed to 10  $\mu$ A.

(i.e.)

$\Delta I_{OUT}=1.E-02$  (A) means load current fluctuation from 10  $\mu$ A to 10 mA

$V_{IN} = V_{OUT}(S) + 1V, CL = 1\mu F$

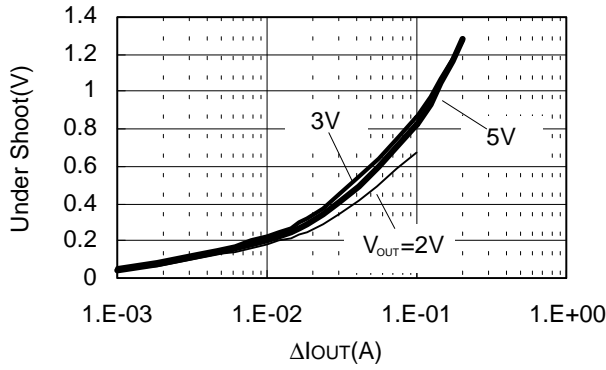

Output capacitor (CL) dependence of undershoot

$V_{IN} = V_{OUT}(S) + 1V, I_{OUT} = 10\mu A \rightarrow 30mA$

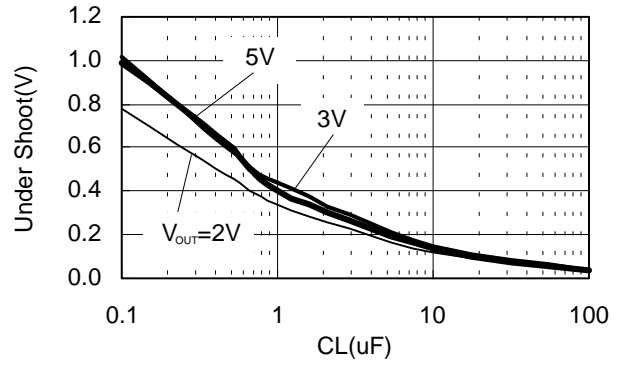

VDD dependencies of undershoot

$V_{IN} = VDD, I_{OUT} = 10\mu A \rightarrow 30mA, CL = 1\mu F$

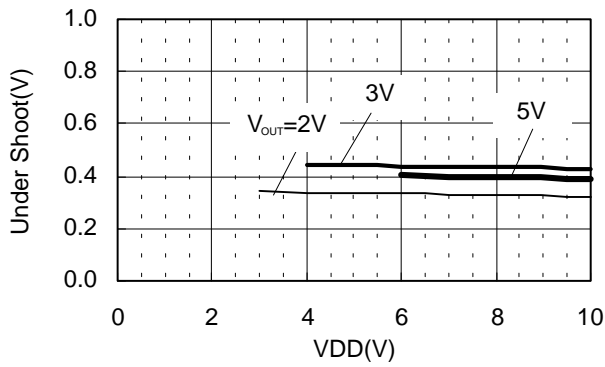

Temperature dependencies of undershoot

$V_{IN} = V_{OUT}(S) + 1V, I_{OUT} = 10\mu A \rightarrow 30mA, CL = 1\mu F$

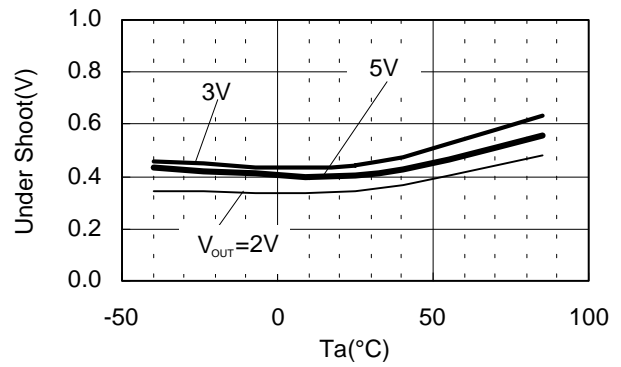

● Dimensions 外形図

Unit : mm

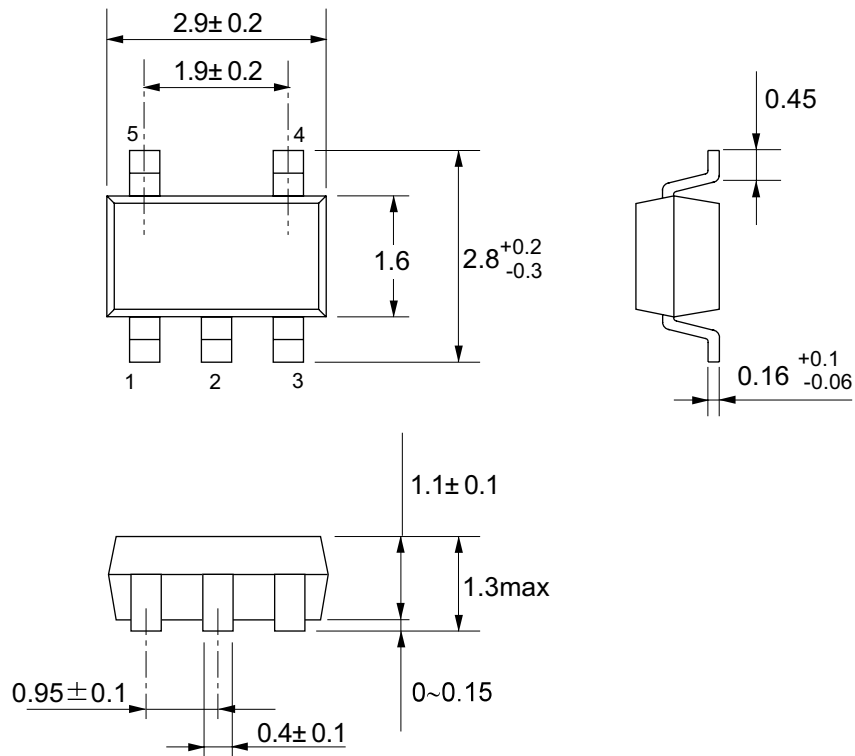

No. : MP005-A-P-SD-1.1

● Taping Specifications テーピング図

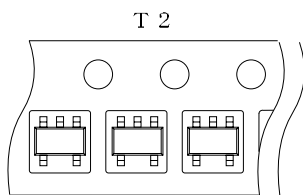
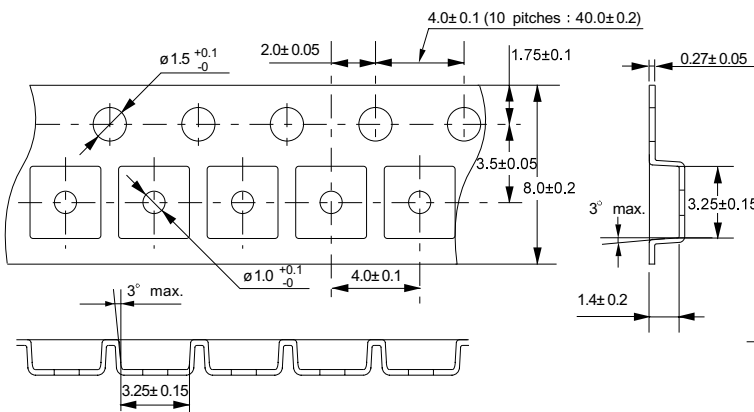

Feed direction  
引き出し方向

No. : MP005-A-C-SD-1.0

● Reel Specifications リール図

3000 pcs./reel

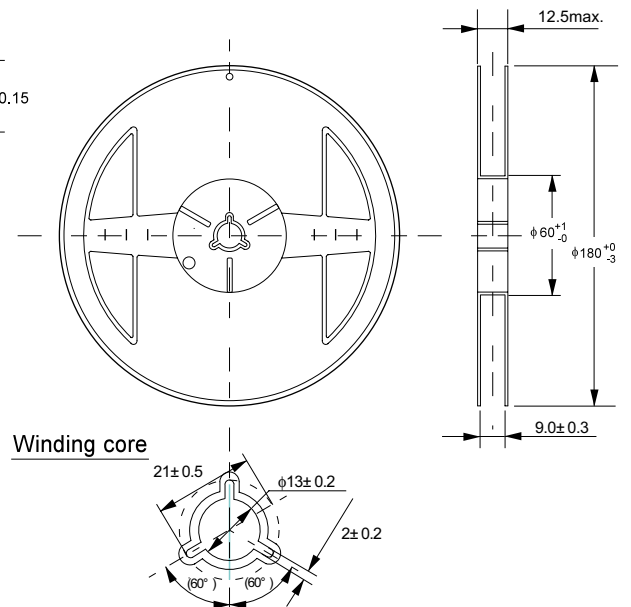

No. : MP005-A-R-SD-1.0

Unit : mm

● Dimensions

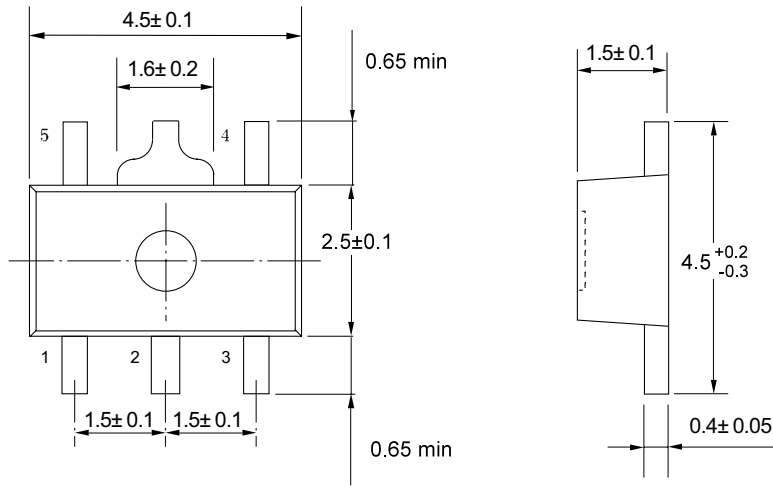

No. : UP005-A-P-SD-1. 1

● Taping Specifications

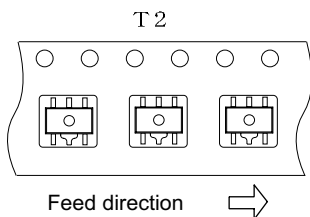
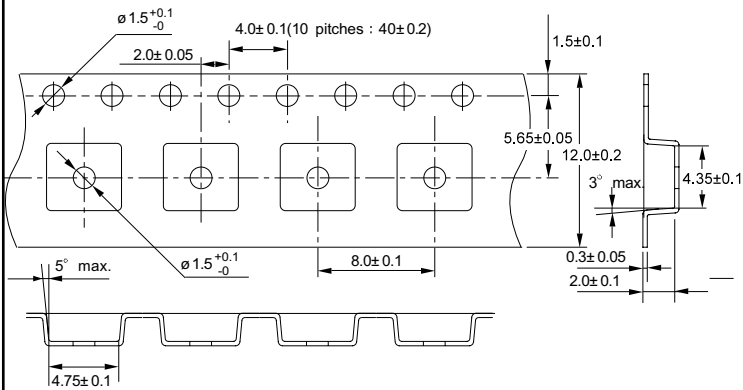

No. : UP005-A-C-SD-1. 0

● Reel Specifications

1 reel holds 1000 ICs.

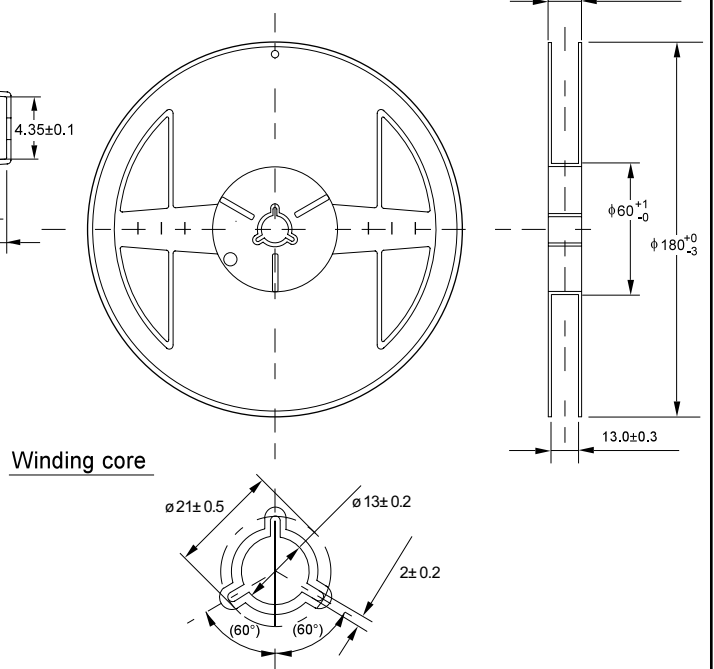

No. : UP005-A-R-SD-1. 0

● SOT-23-5

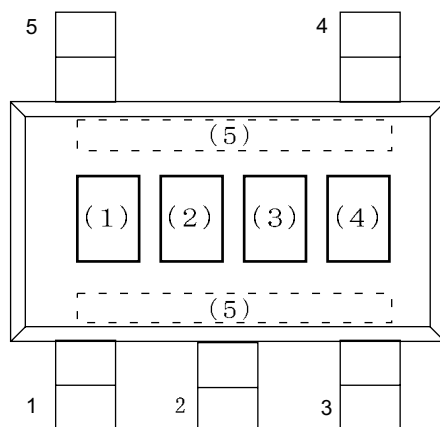

(1) to (3) : Product name (abbreviation)

(4) : Month of assembly

(5) : Dot on one side (Year and week of assembly)

No. : MP 0 0 5 - A - M - S 1 - 1 . 0

● SOT-89-5

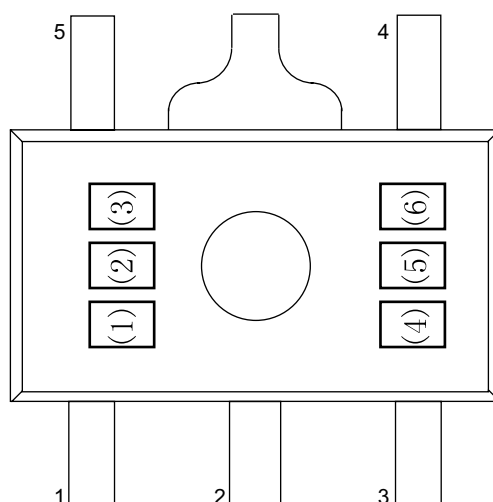

(1) to (3) : Product name (abbreviation)

(4) : Year of assembly

(5) : Month of assembly

(6) : Week of assembly

No. : UP 0 0 5 - A - M - S 1 - 1 . 0

- The information described herein is subject to change without notice.
- Seiko Instruments Inc. is not responsible for any problems caused by circuits or diagrams described herein whose related industrial properties, patents, or other rights belong to third parties. The application circuit examples explain typical applications of the products, and do not guarantee the success of any specific mass-production design.
- When the products described herein are regulated products subject to the Wassenaar Arrangement or other agreements, they may not be exported without authorization from the appropriate governmental authority.
- Use of the information described herein for other purposes and/or reproduction or copying without the express permission of Seiko Instruments Inc. is strictly prohibited.
- The products described herein cannot be used as part of any device or equipment affecting the human body, such as exercise equipment, medical equipment, security systems, gas equipment, or any apparatus installed in airplanes and other vehicles, without prior written permission of Seiko Instruments Inc.
- Although Seiko Instruments Inc. exerts the greatest possible effort to ensure high quality and reliability, the failure or malfunction of semiconductor products may occur. The user of these products should therefore give thorough consideration to safety design, including redundancy, fire-prevention measures, and malfunction prevention, to prevent any accidents, fires, or community damage that may ensue.