

 **SUMITOMO ELECTRIC INDUSTRIES, LTD.**

Japan
Sumitomo Electric Industries, Ltd.
(Tokyo)

3-9-1 Shibaura Rune-site Tower,
Shibaura, Minato-ku, Tokyo
108-8539, Japan
Tel: +81-3-6722-3283
Fax: +81-3-6722-3284

(Osaka)

4-5-33, Kitahama, Chuo-ku, Osaka
541-0041, Japan
Tel: +81-6-6220-4245
Fax: +81-6-6220-6231

Sumitomo Electric Device
Innovations, INC.

1, Kanai-cho, Sakae-ku,
Yokohama, Kanagawa
244-0845, Japan
Tel: +81-45-853-8150
Fax: +81-45-853-8174
www.sedi.co.jp

North America
Sumitomo Electric Device
Innovations USA

West Coast (Headquarters)
2355 Zanker Rd.
San Jose, CA 95131, USA
Tel: (408) 232-9500
Fax: (408) 428-9111
www.sei-device.com

East Coast

4021 Stirrup Creek Drive, Suite 200
Durham, NC 27703, USA
Tel: (919) 361-1600
Fax: (919) 361-1619

Europe
Sumitomo Electric Europe, Ltd.

220 Centennial Park
Elstree WD6 3SL United Kingdom
Tel: +44 (0)20 89538118
Fax: +44 (0)20 89538228



Wireless Device Products

Sumitomo Electric Industries – Reliable, Advanced Technology

Generating Value for the Customer

As an industry pioneer for over 30 years, Sumitomo Electric Industries has overcome many technical challenges to become the most respected supplier of compound semiconductor products. Our advanced technologies and solutions continue to meet the demand of growing and diverse markets in the area of information/communications and sensor/radar. At Sumitomo Electric Industries, we are committed to providing the best value for our customers while protecting the global environment.

Contents

● Total RF Solutions	P3
● GaN HEMTs	
GaN HEMTs	P5
● MMICs	
C to Ka Band Power Amplifier MMICs (Packages)	P7
C to V Band Power Amplifier MMICs (Chip)	P9
Ku to V Band Low Noise Amplifier MMICs	P11
Ku to Ka Band Converter MMICs	P13
Ku to V Band Multiplier MMICs	P14
Voltage Controlled Oscillator MMICs	P15
24GHz Oscillator MMICs	P16
● GaAs FETs	
Internally Matched High Power GaAs FETs	P17
High Power GaAs FETs	P21
Small Signal GaAs FETs	P23
GaAs FETs Chip	P24
● Low-noise HEMTs	
GaAs HEMTs	P25
● Package	P26
● Creating Value for Customers	P33

Total RF Solutions from SUMITOMO ELECTRIC

Device Index



Applications

WCDMA
UMTS

WiMAX
WLAN

P-to-P
SATCOM

VSAT
DBS

P-to-P

VSAT

FWA
P-to-P

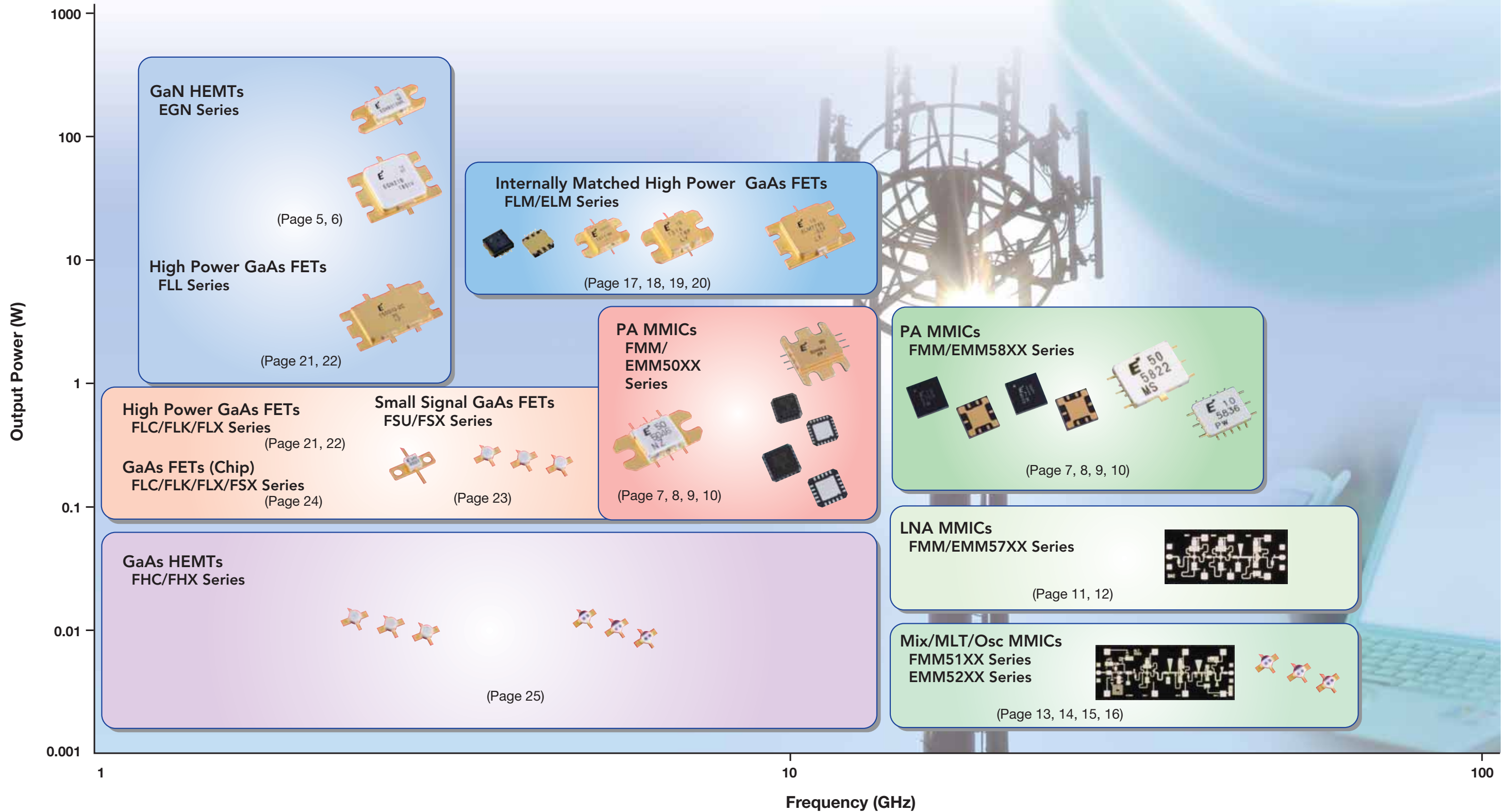

GaN HEMTs (High Electron Mobility Transistors)

GaN HEMTs (High Electron Mobility Transistors)

Features

- High Channel Temperature (Tch): Up to 250°C
- Higher Impedance: ~20Ω (Easy to Match)
- High Operating Voltage: 50V
- High Breakdown Voltage: 250V
- High Power: Up to 320W
- High Efficiency: 70% @P3dB, C series
- High Efficiency: >32% @LTE Pout (Ave) see BTS (Final stage)
- High Gain: 18dB @2.1GHz, C series
- Excellent suitability with Digital Pre-Distortion System

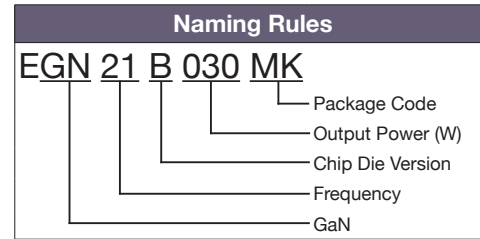

For General Purpose

Part Number	Frequency (GHz)	P3dB Typ. (dBm)	GL Typ. (dB)	η @P3dB Typ. (%)	IDS (DC) (mA)	Rth Typ. (°C/W)	Outline/Package Code
EGNB010MK	3.5	41.0	13.0	60	100	4.5	MK
EGNB030MK	2.7	46.5	13.0	60	200	2.0	
EGNB045MK	2.2	47.5	13.0	60	250	1.4	
EGNB070MK	0.9	49.5	18.0	70	400	1.5	
EGNB090MK	0.9	51.0	18.0	70	500	1.2	
EGNB060M1A*	2.7	49.0	12.0	55	400	1.1	M1A
EGNB090M1A*	2.2	50.0	11.5	55	500	0.75	
EGNB180M1A*	0.9	53.5	17.5	65	1000	0.65	

*: Under Development, Sample Available

For BTS (Final Stage)

Part Number	Application	Frequency (GHz)	Psat*1 Typ. (dBm)	Pout (Ave.) Typ. (dBm)	GP Typ. (dB)	η @Pout (Ave.) Typ. (%)	IDS (DC) (mA)	Rth Typ. (°C/W)	Outline/Package Code
EGN21B090IV	2.1G LTE	2.14	50.0	42.0 ²	16.0 ²	33 ²	500	1.2	IV
EGN21B180IV	2.1G LTE	2.14	53.0	45.0 ²	16.0 ²	32 ²	1000	0.6	
EGNC105MK	0.9G LTE	0.9	51.0	43.0 ³	20.0 ³	35 ³	400	2.0	MK
EGNC160MK	0.9G LTE	0.9	52.5	44.5 ³	18.0 ³	35 ³	600	1.4	
EGNC210MK	0.9G LTE	0.9	53.5	45.5 ³	17.5 ³	35 ³	750	1.1	
EGN16C105MK	1.6G LTE	1.6	50.5	42.5 ³	19.0 ³	33 ³	400	2.0	
EGN21C070MK	2.1G LTE	2.14	49.5	41.5 ³	17.0 ³	33 ³	300	2.5	
EGN21C105I2D	2.1G LTE	2.14	50.3	42.0 ²	18.0 ²	32 ²	400	2.0	I2D
EGN21C210I2D	2.1G LTE	2.14	53.0	45.0 ²	18.0 ²	32 ²	750	1.1	I2D
EGN21C320IV	2.1G LTE	2.14	55.0	47.0 ²	18.0 ²	31 ²	1100	0.75	IV
EGN26C070I2D	2.6G WiMAX	2.6	48.8	40.8 ³	18.0 ³	35 ³	300	2.5	I2D

*1: 10%-duty RF pulse (DC supply constant)

*2: Pout=(Ave.), f0=2.135GHz, f1=2.145GHz, W-CDMA (3GPP3.4 12-00) BS-1 64ch 47.5% clipping modulation (PAR=8.5dB@0.01%)

*3: Pout=(Ave.), W-CDMA (3GPP3.4 12-00) BS-1 64ch 85% clipping modulation (PAR=8.5dB@0.01%)

For BTS (Driver Stage)

Part Number	Frequency (GHz)	Psat*1 Typ. (dBm)	Pout*2 (Ave.) Typ. (dBm)	GP*2 Typ. (dB)	η *2@Pout (Ave.) Typ. (%)	IDS (DC) (mA)	Rth Typ. (°C/W)	Outline/Package Code
EGN21C020MK	2.14	43.5	30.0	19.0	12.5	100	6.0	MK
EGN21C030MK	2.14	45.0	31.5	19.0	12.5	150	5.0	
EGN26C020MK	2.6	43.5	30.0	18.0	12.5	100	6.0	
EGN26C030MK	2.6	45.0	31.5	18.0	12.5	150	5.0	

*1: 10%-duty RF pulse (DC supply constant)

*2 : Pout=(Ave.), CW

Note: Tc (op)=+25°C



C to Ka Band Power Amplifier MMICs (Packages)

SEDI provides GaAs power amplifier MMICs mounted in a suitable high frequency package with output power 50mW - 4W at frequencies ranging from C-band to Ka-band. SEDI provides various types of packages including highly reliable hermetically sealed types, low cost surface mount types and very low cost QFN types. These MMICs can be packaged to meet the customer's cost/performance requirements.

Features

- Input and Output Internally Matched $Z_{in}/Z_{out} = 50\Omega$
- High Output Power (Up to 4W)
- High Gain
- Low Distortion
- Small Hermetically Sealed Package (V1B/VU/VF/GJ)
- Low Cost Surface Mount Package (ZV/ZB/V1B/VU/YC/YD/YE/YF)

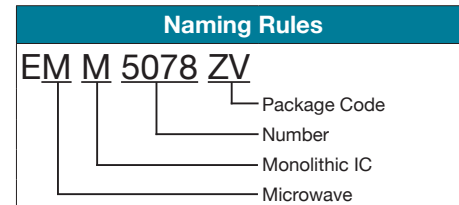

Power Amplifier MMIC Lineup (Package)

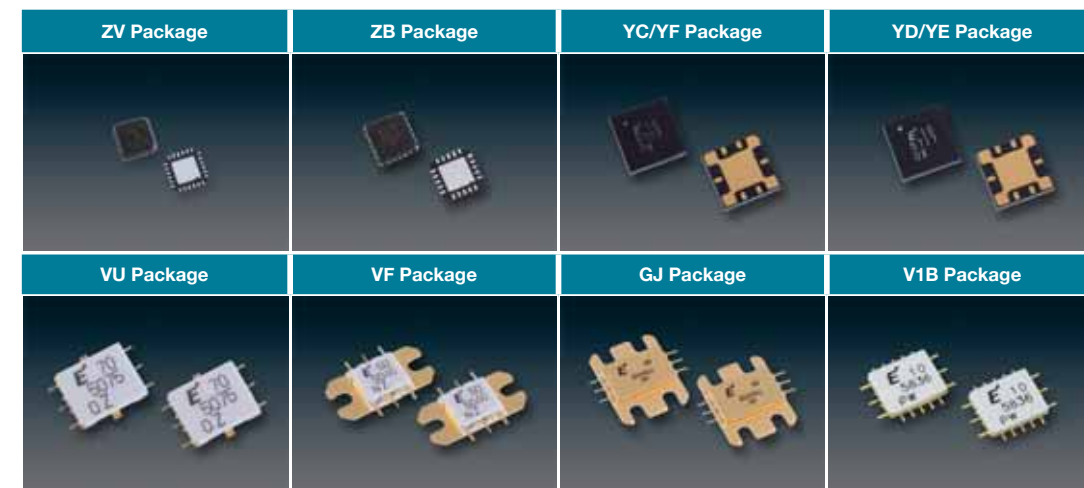
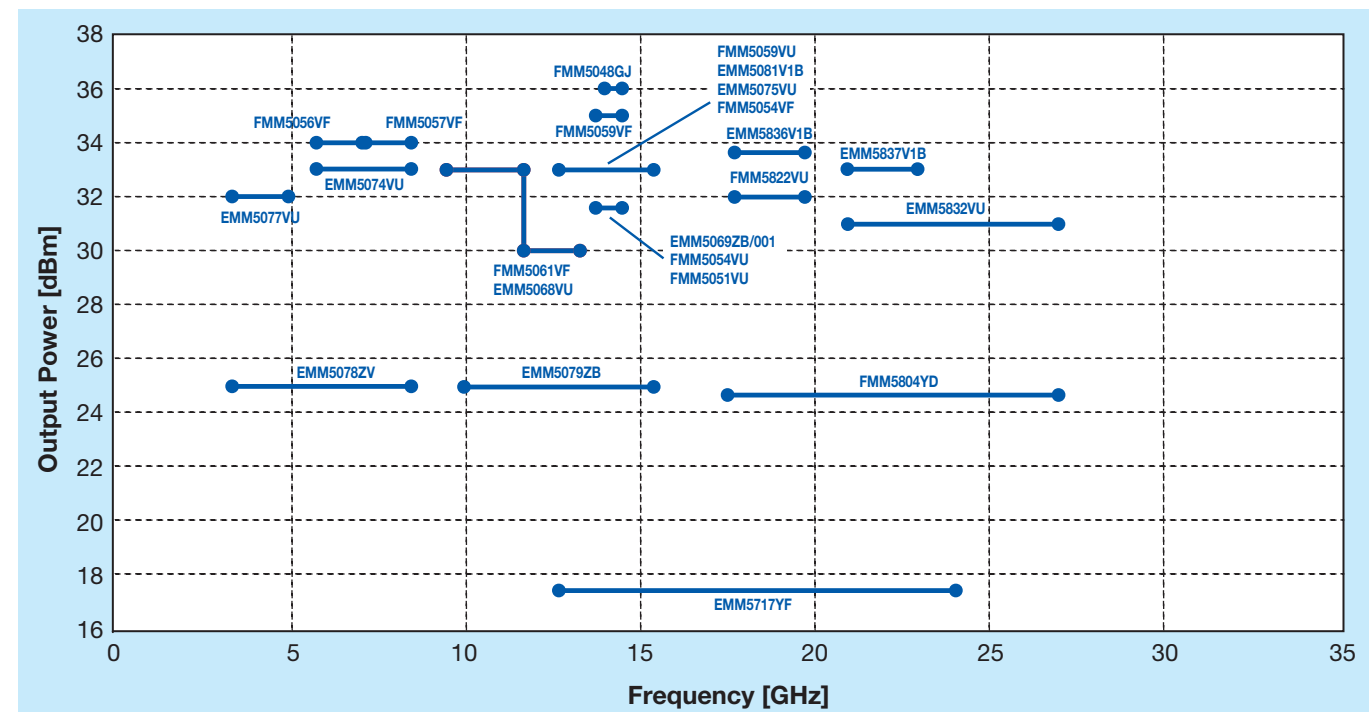

C to Ka Band Power Amplifier MMICs (Packages)

Specifications

Ta=+25°C

Part Number	Frequency Range f (GHz)	Output Power at 1dB G.C.P. P1dB dBm (Typ.)	Gain at 1dB G.C.P. G1dB dB (Typ.)	3rd. Order Intercept Point OIP3 dBm (Typ.)	Drain-Source Voltage VDD (V)	Drain Current at 1dB G.C.P. IDD mA (Typ.)	Outline/Package Code	Function/Application
EMM5078ZV	3.4-8.5	26	29	35	6	350	ZV	Driver Amp., LO Buffer Amp. C-Band VSAT and Radio Link
EMM5077VU	3.4-5.0	31 (f=3.4-4.2GHz) 29.5 (f=4.2-5.0GHz)	25	39.5 (f=3.4-4.2GHz) 38 (f=4.2-5.0GHz)	6	1200 (f=3.4-4.2GHz) 1250 (f=4.2-5.0GHz)	VU	Power Amp. Radio Link
EMM5074VU	5.8-8.5	32 (f=5.8-7.1GHz) 33 (f=7.1-8.5GHz)	26	41	6	1400 (f=5.8-7.1GHz) 1450 (f=7.1-8.5GHz)	VU	Power Amp. C-Band VSAT and Radio Link
FMM5056VF	5.8-7.2	34	28	-	10	1100	VF	Power Amp. Radio Link
FMM5057VF	7.1-8.5	34	26	-	10	1100	VF	
EMM5068VU	9.5-13.3	33 (f=9.5-11.7GHz) 31 (f=11.7-13.3GHz)	25 (f=9.5-11.7GHz) 23 (f=11.7-13.3GHz)	40	6	1500 (f=9.5-11.7GHz) 1400 (f=11.7-13.3GHz)	VU	Power Amp. Radio Link
FMM5061VF	9.5-13.3	33 (f=9.5-11.7GHz) 31 (f=11.7-13.3GHz)	26 (f=9.5-11.7GHz) 24 (f=11.7-13.3GHz)	41.5	6	1700 (f=9.5-11.7GHz) 1500 (f=11.7-13.3GHz)	VF	
EMM5079ZB	10-15.4	25.5 (f=10-11.7GHz) 24 (f=11.7-15.4GHz)	22	31 (f=10-11.7GHz) 35 (f=11.7-15.4GHz)	6	380	ZB	Driver Amp., LO Buffer Amp. Ku-Band VSAT and Radio Link
EMM5717YF	12.7-24	17.5	23	29	3	180	YF	Power Amp. Ku-Band VSAT and Radio Link
EMM5075VU	12.7-15.4	33	25	42	6	1500	VU	
FMM5051VU	13.75-14.5	31.5	30.5	-	5	800	VU	Power Amp. Ka-Band VSAT
FMM5054VU	13.75-14.5	31	29	37	6	950	VU	
FMM5054VF	13.75-14.5	33	31	37	7	1050	VF	
EMM5069ZB/001	13.75-14.5	32.5	29	37.5	5	1500	ZB	
EMM5081V1B	13.75-14.5	33.5	29	39.5	6	1400	V1B	
FMM5059VU	13.75-14.5	33.5	29	39.5	6	1400	VU	
FMM5059VF	13.75-14.5	35	28	40	7	1600	VF	
FMM5048GJ	13.75-14.5	36	26	-	10	2100	GJ	
FMM5804YD	17.5-26.5	24.5	16	-	6	350	YD	Driver Amp. Ka-Band VSAT and Radio Link
FMM5822VU	17.7-19.7	32	21	38.5	6	1100	VU	Power Amp. Radio Link
EMM5836V1B	17.7-19.7	33.5	26	40	6	1800	V1B	
EMM5837V1B	21.2-23.6	33	21	41	6	1800	V1B	
EMM5832VU	21.2-26.5	31	19	36.5	6	1000	VU	

G.C.P.: Gain Compression Point

C to V Band Power Amplifier MMICs (Chip)

SEDI is providing a full line-up of GaAs power amplifier MMIC chips with output power at 50mW to 3W. These MMICs are designed for VSAT (Very Small Aperture Terminal) and radio link transmitter applications that require high power, high gain and low distortion in a 50Ω system. SEDI has a full line-up of MMIC products specified from C-band through V-band.

Features

- Input and Output Internally Matched $Z_{in}/Z_{out} = 50\Omega$
- High Output Power (Up to 3W)
- High Gain
- Low Distortion
- High Reliability

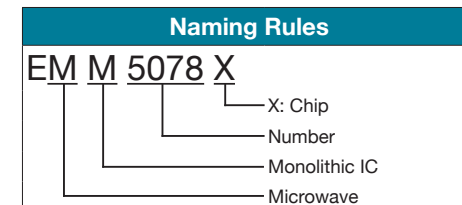

◆ Power Amplifier MMIC Lineup (Chip)

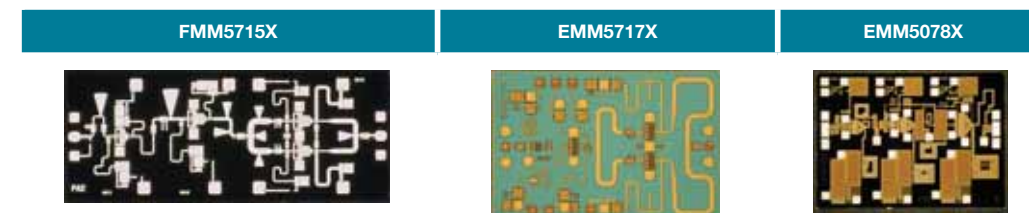
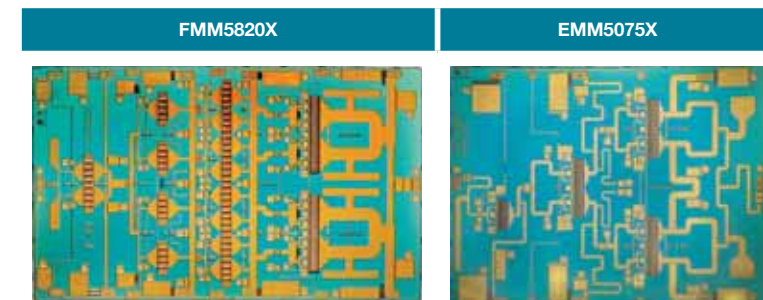
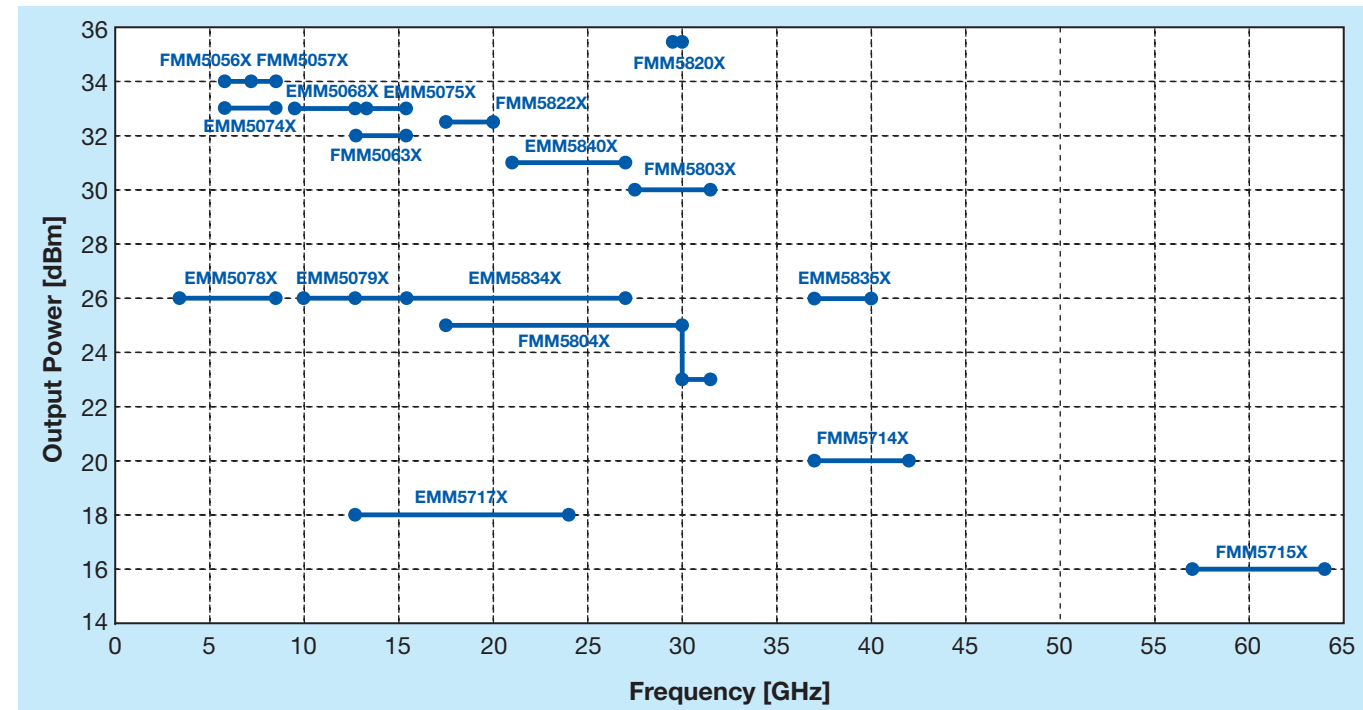

C to Ka Band Power Amplifier MMICs (Packages)

Specifications

Ta=+25°C

Part Number	Frequency Range f (GHz)	Output Power at 1dB G.C.P. P1dB dBm (Typ.)	Gain at 1dB G.C.P. G1dB dB (Typ.)	3rd. Order Intercept Point OIP3 dBm (Typ.)	Drain-Source Voltage VDD (V)	Drain Current at 1dB G.C.P. IDD mA (Typ.)	Function/Application
EMM5078X	3.4-8.5	26	29	35	6	350	Driver Amp., LO Buffer Amp. C-Band VSAT and Radio Link
EMM5074X	5.8-8.5	32 (f=5.8-7.1GHz) 32.5 (f=7.1-8.5GHz)	27	41	6	1450	Power Amp. C-Band VSAT and Radio Link
FMM5056X	5.8-7.2	34	28	-	10	1100	
FMM5057X	7.1-8.5	34	26	-	10	1100	Power Amp. Radio Link
EMM5068X	9.5-13.3	33	25	42.5	6	1500	
EMM5079X	10-15.4	25	22.5	31 (f=10-11.7GHz) 35 (f=11.7-15.4GHz)	6	350	Driver Amp., LO Buffer Amp. Ku-Band VSAT and Radio Link
EMM5717X	12.7-24	18	22	-	3	180	
EMM5834X	12.7-27	26	23	32.5	6	370	
FMM5063X	12.75-15.4	32	29	38.5	6	1000	Power Amp. Ku-Band VSAT and Radio Link
EMM5075X	12.7-15.4	33	26	43.5	6	1300	
FMM5804X	17.5-31.5	25 (f=17.5-30GHz) 23 (f=30-31.5GHz)	18	-	6	300	Driver Amp. Ka-Band VSAT and Radio Link
FMM5822X	17.5-20	32.5	21	41	6	1000	Power Amp. Radio Link
EMM5840X	21-27	31	24	39	6	1000	
FMM5803X	27.5-31.5	30	14 (f=27.5-30GHz) 12 (f=30-31.5GHz)	-	6	700	Power Amp. Ka-Band VSAT and Radio Link
FMM5820X	29.5-30	35	23	-	7	2200	
FMM5714X	37-42	17 (f=37GHz) 20 (f=42GHz)	21	26.5 (f=37GHz) 29 (f=42GHz)	3	200	Power Amp. Ku-Band VSAT
EMM5835X	37-40	27	20	36	6	600	Power Amp. Radio Link
FMM5715X	57-64	16	17	-	3	150	

G.C.P.: Gain Compression Point

Ku to V Band Low Noise Amplifier MMICs

The FMM/EMM57-series MMICs are designed for VSAT and radio link receiver applications. The performance of low noise figure and high associated gain are achieved using pHEMT technology and EB lithography process. SEDI has line-ups of MMIC products specified from Ku-band through V-band.

Features

- Input and Output Internally Matched $Z_{in}/Z_{out} = 50\Omega$
- Low Noise Figure
- High Gain
- Wide Band
- High Reliability Bare Die (X)
- Low Cost Surface Mount Package (YC/YF)

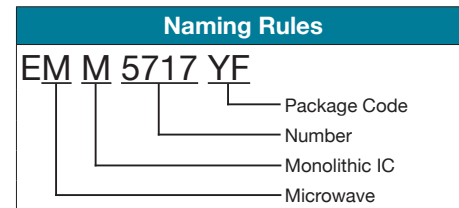

Low Noise Amplifier MMIC Lineup

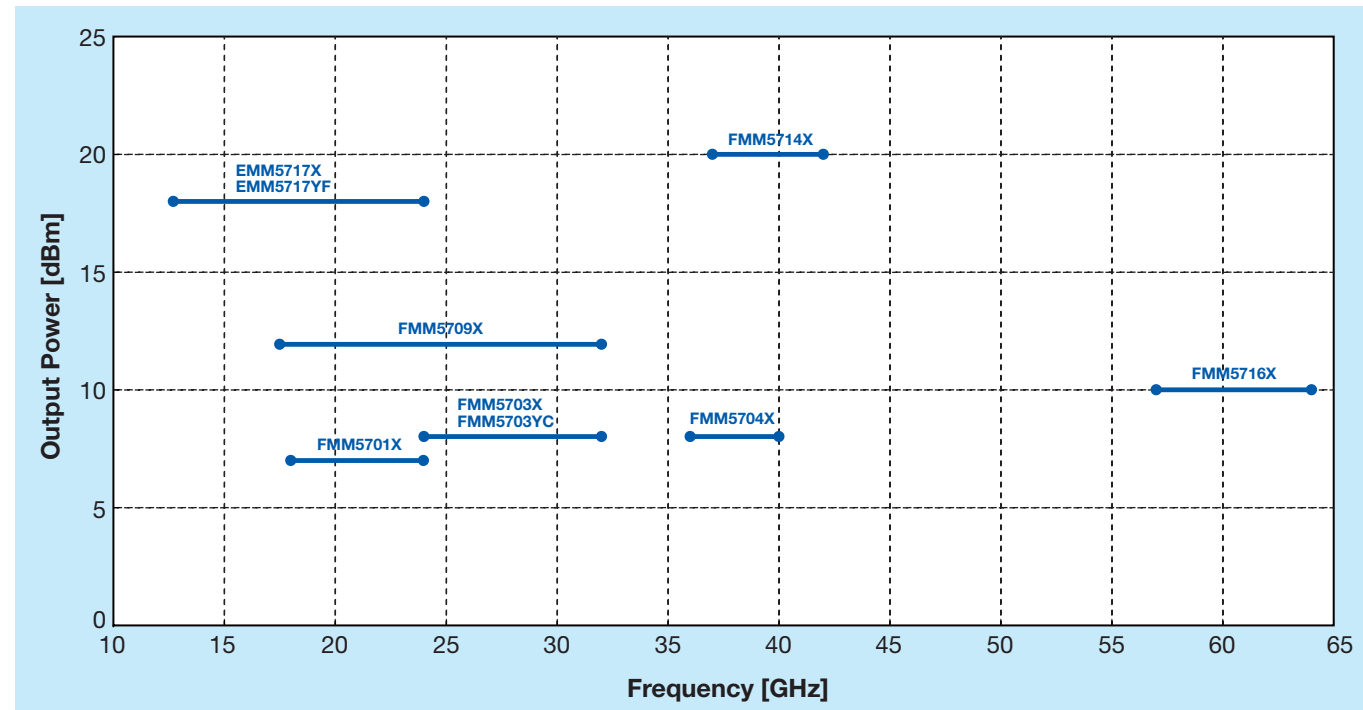

Ku to V Band Low Noise Amplifier MMICs

Specifications

Ta=+25°C

Part Number	Frequency Range f (GHz)	Drain-Source Voltage VDD (V)	Noise Figure NF dB (Typ.)	Associated Gain Gas dB (Typ.)	Output Power at 1dB G.C.P. P1dB dBm (Typ.)	Drain Current IDD mA (Typ.)	Outline/Package Code	Application
EMM5717X	12.7-24	3	2.5	23	18	180	Chip	VSAT and Radio Link
EMM5717YF	12.7-24	3	3	23	17.5	180	YF	
FMM5709X	17.5-32	3	2.5	23	12.5	60	Chip	
FMM5701X	18-28	5	1.5	13.5	7	12	Chip	
FMM5703X	24-32	3	2	18	9	20	Chip	
FMM5703YC	24-30	3	2.5	18	6	20	YC	
FMM5704X	36-40	3	2	18	9	20	Chip	
FMM5714X	37-42	3	3	22	17 (f=37GHz) 20 (f=42GHz)	200	Chip	
FMM5716X	57-64	3	5	22	10	30	Chip	

G.C.P.: Gain Compression Point

Ku to Ka Band Converter MMICs

SEDI provides Mixer MMICs that are designed for VSAT and radio link applications. These devices use an up-converter for the transmitter and a down-converter for the receiver.

These MMICs include a local buffer amplifier integrated on MMIC chip.

Features

- Wide Frequency Range
- High Conversion Gain
- High Integrated
- Low Distortion

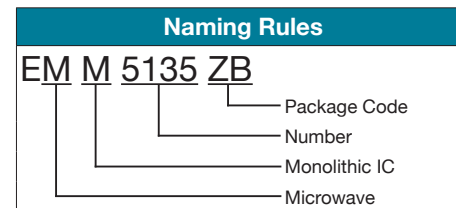

Specifications

Ta=+25°C

Part Number	RF Frequency Range f (GHz)	Drain-Source Voltage VDD (V)	Conversion Gain (dB)	Current Consumption (mA)	Outline/Package Code	Function
EMM5135ZB	13.75-14.5	5	8	130	ZB	with LO/RF AMP, Up Converter
FMM5116X	20-32	5	-10	140	Chip	with Doubler, Up Converter
FMM5116YE*	20-30	5	-11	160	YE	
FMM5117YE*	20-30	5	-11	160	YE	with Doubler, Down Converter

*: Under Development

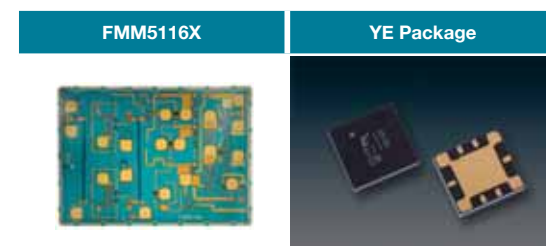

Ku to V Band Multiplier MMICs

These multipliers were developed for the local oscillator of a radio link transmitter/receiver. This MMIC is designed for a wide frequency range with high conversion gain.

Features

- Wide Frequency Range
- High Conversion Gain

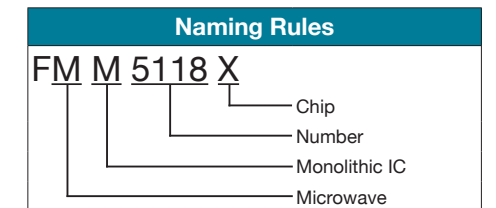

Specifications

Ta=+25°C

Part Number	RF Frequency Range f (GHz)	Drain-Source Voltage VDD (V)	Conversion Gain (dB)	Current Consumption (mA)	Function
FMM5118X	20-32	5	14	130	Doubler
FMM5125X	57-64	5	-5	100	Quadrupler



Voltage Controlled Oscillator MMICs

24GHz Oscillator MMICs

The SEDI EMM5207ZF uses a newly developed VCO MMIC technology. This device achieves low phase noise performance while using MESFET technology. The EMM5207ZF is mounted in a low cost plastic package to meet the demand for low cost Ku-band VSAT systems.

The EMM5206LP is an oscillator for Ku-band to K-band sensor applications. This device shows negative resistance in the frequency band and operates with a single positive bias voltage.

Features

- On Chip Resonator
- Low Phase Noise: $\Delta n = -90\text{dBc/Hz}$ @100kHz offset
- High Frequency Modulation Linearity
- f/2 PLL Monitor Port

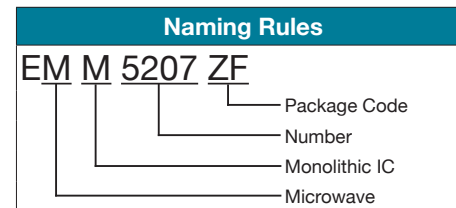

Features

- High Output Power: $P_{out} = 5\text{dBm}$ @Vdd = 4V (Typ.)
- Low Power Consumption: $I_{dd} = 20\text{mA}$ @Vdd = 4V (Typ.)
- Low Phase Noise: $\Delta n = -100\text{dBc/Hz}$ @100kHz offset, $f_{osc} = 24\text{GHz}$
- Low Spurious Level: $RJ2nd = -40\text{dBc}$ (Typ.)

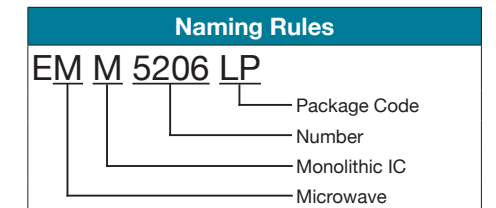

Specifications

Ta=+25°C

Part Number	Oscillation Frequency f_{osc} (GHz)	Drain-Source Voltage $V_{cc}, V_{ccTx}, V_{ccRx}$ (V)	Tuning Voltage (V)	Total Supply Current mA (Typ.)	Output Power P_{out} dBm (Typ.)	Phase Noise at 100kHz offset Δn dBc (Typ.)	Outline/Package Code	Application
EMM5207ZF	12.72~13.85	5	-1.5 ~ -12	115	Tx: 14, Rx: 10.5, Monitor: -3	-95	ZF	Ku-Band VSAT

Tx Frequency Range: 12.72GHz to 13.2GHz, Rx Frequency Range: 12.8GHz to 13.85GHz, RFOut/2 Frequency Range: 6.36GHz to 6.925GHz

Specifications

Ta=+25°C

Part Number	Oscillation Frequency f_{osc} (GHz)	Drain-Source Voltage VDD (V)	Output Power P_{out} dBm (Typ.)	Drain Current I_{dd} mA (Typ.)	Phase Noise at 100kHz offset Δn dBc (Typ.)	2nd Harmonic Rejection $RJ2nd$ dBc (Typ.)	Outline/Package Code	Application
EMM5206LP	15~24.5	4	5	20	-100	-40	LP	Microwave Sensor



Internally Matched High Power GaAs FETs

The FLM/ELM Series are internally matched power GaAs FETs developed for radio link applications which require high power, high gain, and low distortion in a 50Ω system that are available from 2GHz to 15.3GHz frequency bands.

ELM-4PS series are cost effective products of plastic package which can be surface-mounted to save assembly cost. These products can be provided in both taping-reel and Tray.

Features: 4PS series (New Products)

- Input/Output Internally Matched
- Plastic Package for SMT applications
- High Gain
- High Output Power (4W)
- High PAE
- Frequency Bands (5.9 to 6.4GHz, 6.4 to 7.2GHz, 7.1 to 7.9GHz, 7.7 to 8.5GHz)

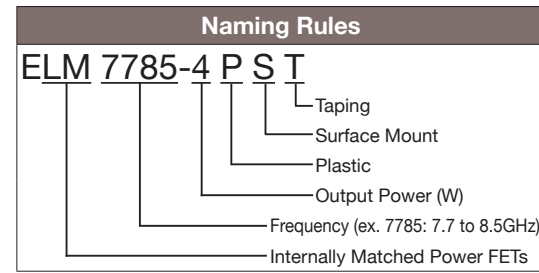

Features

- Input/Output Internally Matched $Z_{in}/Z_{out} = 50\Omega$
- Hermetic Metal Wall package
- High Gain
- High Output Power (Up to 60W)
- Low Distortion
- Covers Wide Band

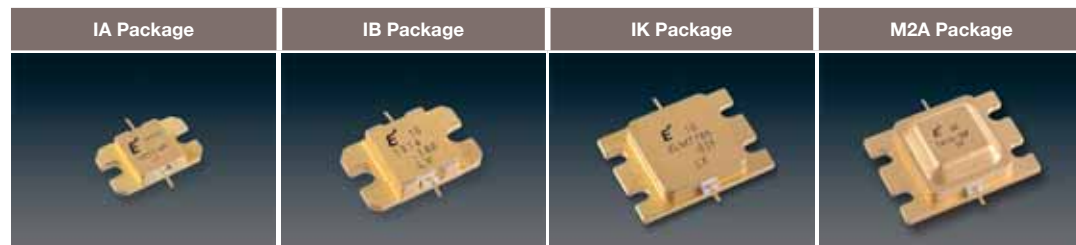
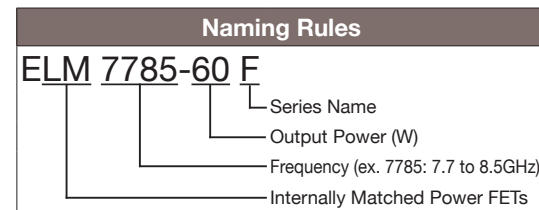

Internally Matched High Power GaAs FET Lineup

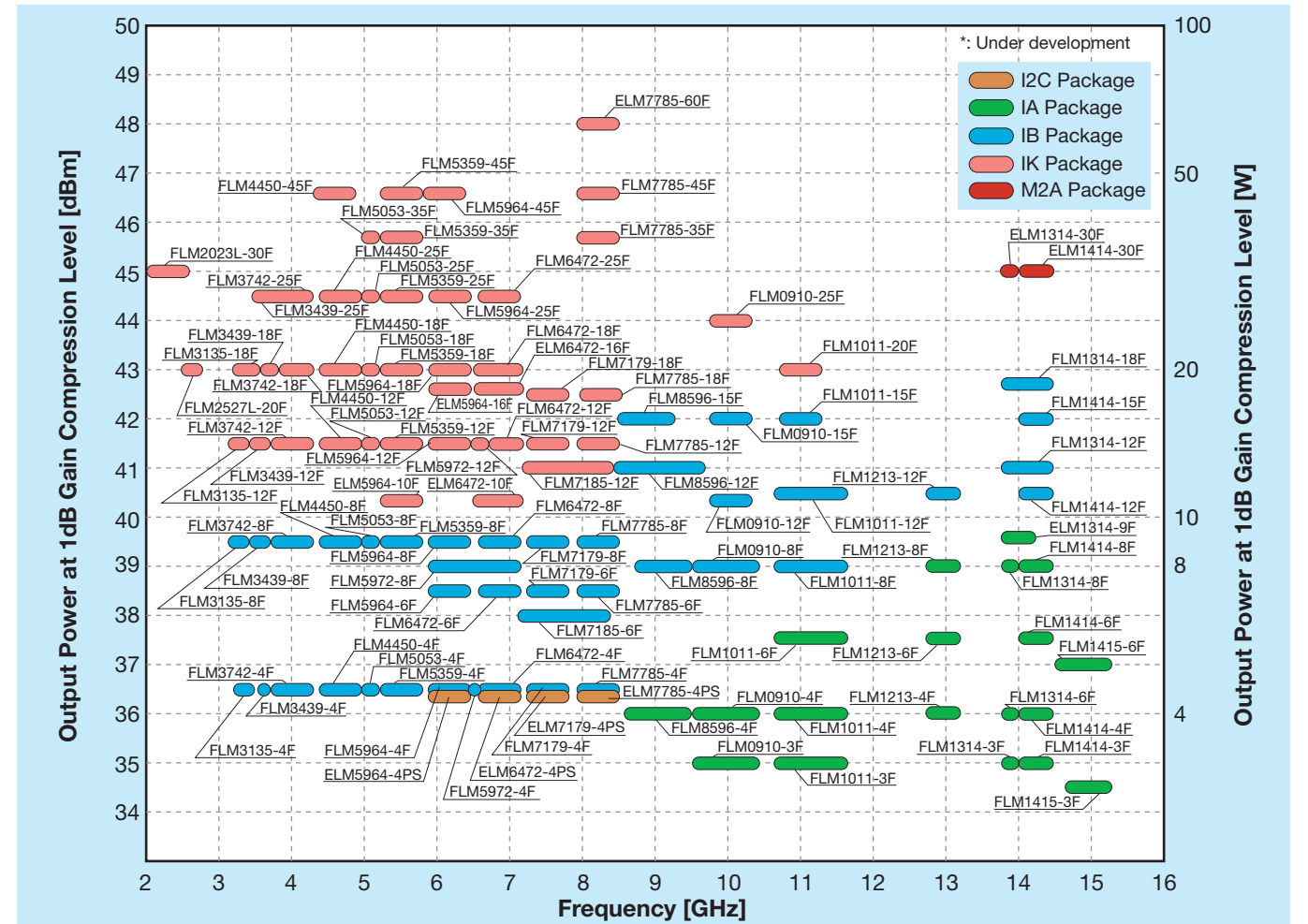

Specifications: 4PS series

Part Number	Frequency Band	2tone test			η_{add} Typ. (%)	Frequency f (GHz)	VDS Typ. (V)	IDS(RF) Typ. (mA)	Rth Typ. (°C/W)	Outline/Package Code	Feature/Application	
		IM3 Typ. (dBc)	@Pout S.C.L. Typ. (dBm)	P1dB Typ. (dBm)								G1dB Typ. (dB)
ELM5964-4PS	C	-43	25.5	36	11.5	37	5.9-6.4	10	1100	4.5	I2C	• Internally matched • Optimized for each frequency band
ELM6472-4PS	C	-43	25.5	36	11	36	6.4-7.2	10	1100	4.5	I2C	
ELM7179-4PS	C	-43	25.5	36	10.5	35	7.1-7.9	10	1100	4.5	I2C	
ELM7785-4PS	C	-43	25.5	36	10	34	7.7-8.5	10	1100	4.5	I2C	

Specifications

Part Number	Frequency Band	2tone test		P1dB Typ. (dBm)	G1dB Typ. (dB)	η add Typ. (%)	Frequency f (GHz)	VDS Typ. (V)	IDS(RF) Typ. (mA)	Rth Typ. (°C/W)	Outline/Package Code	Feature/Application
		IM3 Typ. (dBc)	@Pout S.C.L. Typ. (dBm)									
FLM2023L-30F	L	-45	34.5	45	13	43	2.025-2.285	10	7000	1.2	IK	
FLM2527L-20F	L	-	-	43	11	38	2.5-2.7	10	4800	1.6	IK	
FLM3135-4F	S	-45	25.5	36.5	12	38	3.1-3.5	10	1100	5	IB	
FLM3135-8F	S	-45	28.5	39.5	11	37	3.1-3.5	10	2200	3	IB	
FLM3135-12F	S	-45	30.5	41.5	11.5	40	3.1-3.5	10	3250	2.3	IK	
FLM3135-18F	S	-45	32.0	43	10.5	37	3.1-3.5	10	4800	1.6	IK	
FLM3439-4F	S	-46	25.5	36.5	12	38	3.4-3.9	10	1100	5	IB	
FLM3439-8F	S	-46	28.5	39.5	11	37	3.4-3.9	10	2200	3	IB	
FLM3439-12F	S	-46	30.5	41.5	11.5	40	3.4-3.9	10	3250	2.3	IK	
FLM3439-18F	S	-46	32.0	43	10.5	37	3.4-3.9	10	4800	1.6	IK	
FLM3439-25F	S	-46	33.5	44.5	10.5	41	3.4-3.9	10	6200	1.4	IK	
FLM3742-4F	C	-46	25.5	36.5	12	38	3.7-4.2	10	1100	5	IB	
FLM3742-8F	C	-46	28.5	39.5	11	37	3.7-4.2	10	2200	3	IB	
FLM3742-12F	C	-46	30.5	41.5	11.5	40	3.7-4.2	10	3250	2.3	IK	
FLM3742-18F	C	-46	32.0	43	10.5	37	3.7-4.2	10	4800	1.6	IK	
FLM3742-25F	C	-46	33.5	44.5	10.5	41	3.7-4.2	10	6200	1.4	IK	
FLM4450-4F	C	-46	25.5	36.5	11	37	4.4-5.0	10	1100	5	IB	
FLM4450-8F	C	-46	28.5	39.5	10	36	4.4-5.0	10	2200	3	IB	
FLM4450-12F	C	-46	30.5	41.5	10.5	39	4.4-5.0	10	3250	2.3	IK	
FLM4450-18F	C	-46	32.0	43	9.5	36	4.4-5.0	10	4800	1.6	IK	
FLM4450-25F	C	-46	33.5	44.5	9.5	40	4.4-5.0	10	6200	1.4	IK	
FLM4450-45F	C	-	-	46.5	10	41	4.4-5.0	12	8000	1.1	IK	
FLM5053-4F	C	-46	25.5	36.5	10.5	37	5.0-5.3	10	1100	5	IB	
FLM5053-8F	C	-46	28.5	39.5	9.5	36	5.0-5.3	10	2200	3	IB	
FLM5053-12F	C	-46	30.5	41.5	9.5	38	5.0-5.3	10	3250	2.3	IK	
FLM5053-18F	C	-46	32.0	43	8.5	35	5.0-5.3	10	4800	1.6	IK	
FLM5053-25F	C	-46	33.5	44.5	8.5	39	5.0-5.3	10	6200	1.4	IK	• 50Ω internally matched
FLM5053-35F	C	-45	34.5	45.5	8	35	5.0-5.3	10	8000	1.1	IK	• No external matching
FLM5359-4F	C	-46	25.5	36.5	10.5	37	5.3-5.9	10	1100	5	IB	• Optimized for each frequency band
FLM5359-8F	C	-46	28.5	39.5	9.5	36	5.3-5.9	10	2200	3	IB	
FLM5359-12F	C	-46	30.5	41.5	9.5	38	5.3-5.9	10	3250	2.3	IK	
FLM5359-18F	C	-46	32.0	43	8.5	35	5.3-5.9	10	4800	1.6	IK	
FLM5359-25F	C	-46	33.5	44.5	8.5	39	5.3-5.9	10	6200	1.4	IK	
FLM5359-35F	C	-	-	45.5	9	35	5.3-5.9	10	8500	1.1	IK	
FLM5359-45F	C	-	-	46.5	8.5	36	5.3-5.9	12	8500	0.8	IK	
FLM5964-4F	C	-46	25.5	36.5	10	37	5.9-6.4	10	1100	5	IB	
FLM5964-6F	C	-46	27.5	38.5	10	37	5.9-6.4	10	1625	4	IB	
FLM5964-8F	C	-46	28.5	39.5	10	37	5.9-6.4	10	2200	3	IB	
ELM5964-10F	C	-46	29	40.5	10	39	5.9-6.4	10	2600	3	IK	
FLM5964-12F	C	-46	30.5	41.5	10	37	5.9-6.4	10	3250	2.3	IK	
ELM5964-16F	C	-45	31.5	42.5	10	40	5.9-6.4	10	4000	2.7	IK	
FLM5964-18F	C	-46	32.0	43	10	37	5.9-6.4	10	4875	1.6	IK	
FLM5964-25F	C	-46	33.5	44.5	10	37	5.9-6.4	10	6500	1.4	IK	
FLM5964-35F	C	-40	35.0	45.5	9	36	5.9-6.4	10	8500	1.1	IK	
FLM5964-45F	C	-40	35.5	47	8.5	39	5.9-6.4	10	11000	1.1	IK	
FLM5964-4F/001	C	-45	25.5	36.5	9.5	36	5.85-6.75	10	1100	5	IB	
FLM5964-8F/001	C	-45	28.5	39.5	9	35	5.85-6.75	10	2200	3	IB	
FLM5964-12F/001	C	-45	30.5	41.5	9	37	5.85-6.75	10	3250	2.3	IK	
FLM5964-18F/001	C	-45	31.5	42.5	9	35	5.85-6.75	10	4400	1.6	IK	
FLM5972-4F	C	-45	25.5	36.5	9.5	36	5.9-7.2	10	1100	5	IB	
FLM5972-8F	C	-45	28.0	39.0	8.5	31	5.9-7.2	10	2200	3	IB	
FLM5972-12F	C	-45	30.5	41.5	9.5	37	5.9-7.2	10	3250	2.3	IK	
FLM6472-4F	C	-46	25.5	36.5	9.5	36	6.4-7.2	10	1100	5	IB	
FLM6472-6F	C	-46	27.5	38.5	9.5	37	6.4-7.2	10	1625	4	IB	
FLM6472-8F	C	-46	28.5	39.5	9.5	36	6.4-7.2	10	2200	3	IB	
ELM6472-10F	C	-46	29	40.5	9.5	36	6.4-7.2	10	2600	3	IK	
FLM6472-12F	C	-46	30.5	41.5	9.5	37	6.4-7.2	10	3250	2.3	IK	
ELM6472-16F	C	-45	31.5	42.5	9.5	40	6.4-7.2	10	4000	2.7	IK	
FLM6472-18F	C	-46	32.0	43	9.5	37	6.4-7.2	10	4875	1.6	IK	

Note: Tc (op) = +25°C IM3: 3rd Order Intermodulation Distortion

Specifications

Part Number	Frequency Band	2tone test		P1dB Typ. (dBm)	G1dB Typ. (dB)	η add Typ. (%)	Frequency f (GHz)	VDS Typ. (V)	IDS(RF) Typ. (mA)	Rth Typ. (°C/W)	Outline/Package Code	Feature/Application
		IM3 Typ. (dBc)	@Pout S.C.L. Typ. (dBm)									
FLM6472-25F	C	-46	33.5	44.5	9.5	38	6.4-7.2	10	6500	1.4	IK	
FLM7179-4F	C	-46	25.5	36.5	9	35	7.1-7.9	10	1100	5	IB	
FLM7179-6F	C	-46	27.5	38.5	9	34	7.1-7.9	10	1625	4	IB	
FLM7179-8F	C	-46	28.5	39.5	9	35	7.1-7.9	10	2200	3	IB	
FLM7179-12F	C	-46	30.5	41.5	9	38	7.1-7.9	10	3250	2.3	IK	
FLM7179-18F	C	-46	32.0	42.5	8	30	7.1-7.9	10	4875	1.6	IK	
FLM7185-6F	C	-45	27.0	38.0	8	30	7.1-8.5	10	1625	4	IB	
FLM7185-12F	C	-45	30.0	41.0	8	30	7.1-8.5	10	3250	2.3	IK	
FLM7785-4F	C	-46	25.5	36.5	8.5	35	7.7-8.5	10	1100	5	IB	
FLM7785-6F	C	-46	27.5	38.5	8.5	31	7.7-8.5	10	1750	4	IB	
FLM7785-8F	C	-46	28.5	39.5	8.5	34	7.7-8.5	10	2200	3	IB	
FLM7785-12F	C	-46	30.5	41.5	8.5	34	7.7-8.5	10	3500	2.3	IK	
FLM7785-18F	C	-45	31.5	42.5	7	29	7.7-8.5	10	4700	1.6	IK	
ELM7785-35F	C	-	-	45.5	8.5	35	7.7-8.5	10	8500	1.1	IK	
FLM7785-45F	C	-	-	46.5	7	32.5	7.7-8.5	10	11000	1.1	IK	
ELM7785-60F	C	-	-	48.0	7	37	7.7-8.5	10	13200	0.8	11K	
FLM8596-4F	X	-45	25.5	36.0	7.5	29	8.5-9.6	10	1100	5	IA	
FLM8596-8F	X	-45	28.5	39.0	7.5	29	8.5-9.6	10	2200	3	IB	
FLM8596-12F	X	-45	29.5	40.5	7.5	25	8.5-9.6	10	3600	2.3	IB	
FLM8596-15F	X	-	-	42	7.5	32	8.5-9.6	10	4000	2.3	IB	
FLM0910-3F	X	-46	24.0	35	7.5	29	9.5-10.5	10	825	5	IA	
FLM0910-4F	X	-46	25.5	36	7.5	29	9.5-10.5	10	1100	5	IA	
FLM0910-8F	X	-46	28.5	39	7.5	29	9.5-10.5	10	2200	3	IB	
FLM0910-12F	X	-	-	40.5	7	25	9.5-10.5	10	3500	2.3	IB	
FLM0910-15F	X	-	-	42	7.5	32	9.5-10.5	10	4000	2.3	IB	
FLM0910-25F	X	-	-	44	7	30	9.5-10.5	10	6500	1.4	IK	• 50Ω internally matched
FLM1011-3F	X	-46	24.0	35	7.5	29	10.7-11.7	10	825	5	IA	• No external matching
FLM1011-4F	X	-46	25.5	36	7	29	10.7-11.7	10	1100	5	IA	• Optimized for each frequency band
FLM1011-6F	X	-49	25.0	37.5	7.5	28	10.7-11.7	10	1650	4	IA	
FLM1011-8F	X	-46	28.5	39	7	29	10.7-11.7	10	2200	3	IB	
FLM1011-12F	X	-45	29.5	40.5	6	25	10.7-11.7	10	3500	2.3	IB	
FLM1011-15F	X	-45	30.0	42	7	31	10.7-11.7	10	4000	2.3	IB	
FLM1011-20F	X	-45	31.0	43	7	27	10.7-11.7	10	6000	1.4	IK	
FLM1213-4F	Ku	-46	25.5	36	6.5	28	12.7-13.2	10	1100	5	IA	
FLM1213-6F	Ku	-49	25.0	37.5	7	28	12.7-13.2	10	1650	4	IA	
FLM1213-8F	Ku	-46	28.5	39	6.5	28	12.7-13.2	10	2200	3	IA	
FLM1213-12F	Ku	-45	28.0	40.5	5.5	24	12.7-13.2	10	3300	2.3	IB	
FLM1314-3F	Ku	-45	24.0	35	5.5	27	13.75-14.5	10	825	5	IA	
FLM1314-6F	Ku	-45	26.5	37.5	5.5	22	13.75-14.5	10	1650	4	IA	
FLM1314-8F	Ku	-45	28.0	39	6	27	13.75-14.5	10	2400	2.8	IA	
ELM1314-9F	Ku	-30	33.0	39.5	6.0	30	13.75-14.5	10	2400	3.5	IA	
FLM1314-12F	Ku	-45	29.0	41.0	6	23	13.75-14.5	10	4200	1.8	IB	
FLM1314-18F	Ku	-30	36.0	42.5	6	27	13.75-14.5	10	5000	1.8	IB	
ELM1314-30F	Ku	-30	37.5	45	5	25	13.75-14.5	10	8000	1	M2A	
ELM1314-30F/001	Ku	-30	38.0	44.5	5.5	22	13.75-14.5	10	9000	1	M2A	
FLM1414-3F	Ku	-46	24.0	35	6.5	27	14.0-14.5	10	825	5	IA	
FLM1												

High Power GaAs FETs (10V & 12V Operation)

SEDI has developed 40W - 240W high power Push-Pull GaAs FETs for Mobile Base Station applications such as PHS, Cellular, W-CDMA and WiMAX. Additionally, plastic packaged devices are under development for cost driven systems.

Features

- High Output Power: Up to 240W
- High Gain
- Operating Voltage: 10V, 12V
- Proven Reliability

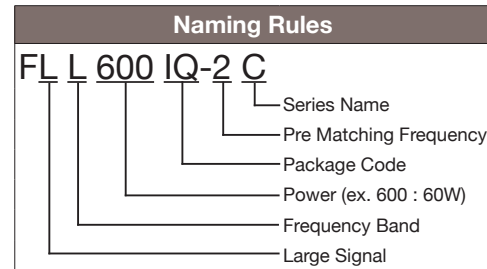

◆ L-Band, S-Band High Output GaAs FET Lineup

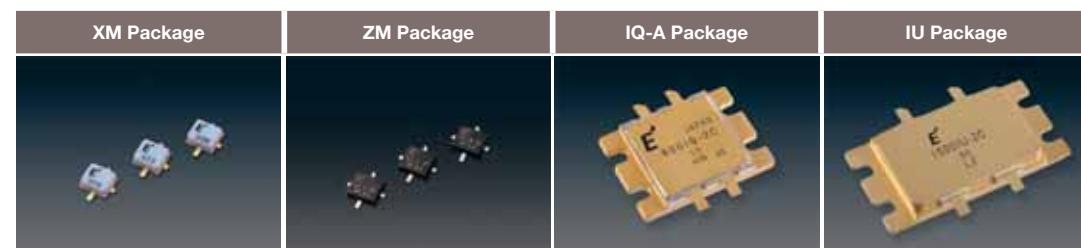
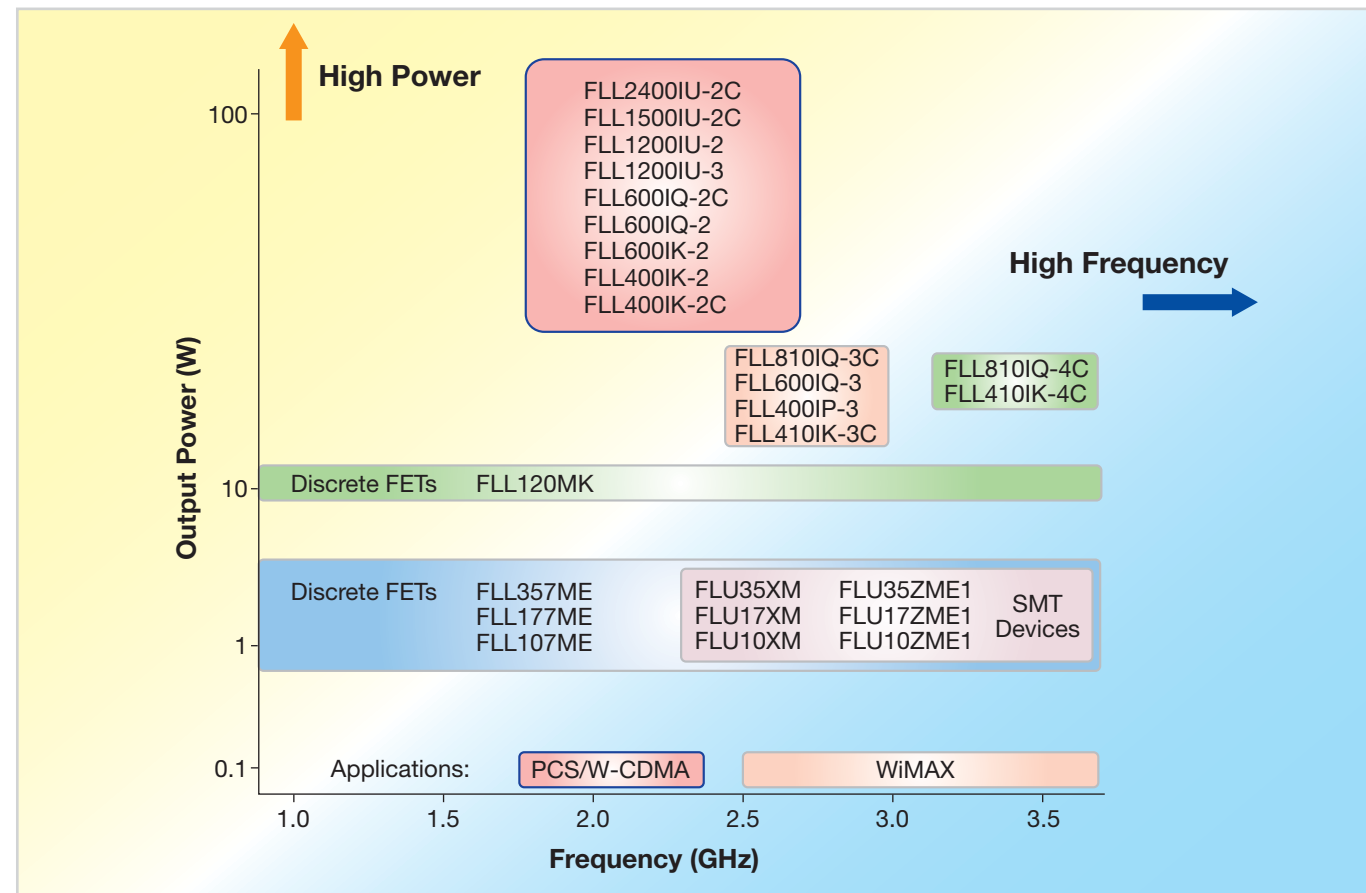

High Power GaAs FETs (10V & 12V Operation)

Specifications

Part Number	Frequency Band	Series	P1dB Typ. (dBm)	G1dB Typ. (dB)	η_{add} Typ. (%)	Frequency (GHz)	VDS Typ. (V)	IDS(DC) Typ. (mA)	Rth Typ. (°C/W)	Outline/Package Code	Feature
FLU10XM	L	FLU	29.5	14.5	47	2	10	180	25	XM	SMT-Device
FLU10ZME1 ^{*4}	L	FLU	29.5	13.0	46	2	10	180	15	ZM	
FLU17XM	L	FLU	32.5	12.5	46	2	10	360	15	XM	
FLU17ZME1 ^{*4}	L	FLU	32.5	12.5	45	2	10	360	12	ZM	
FLU35XM	L	FLU	35.5	12.5	46	2	10	720	7.5	XM	Single-end
FLU35ZME1 ^{*4}	L	FLU	35.5	11.5	45	2	10	720	5	ZM	
FLL107ME	L	FLL	29.5	13.5	47	2.3	10	180	25	ME	
FLL177ME	L	FLL	32.5	12.5	46	2.3	10	360	15	ME	
FLL357ME	L	FLL	35.5	11.5	46	2.3	10	720	7.5	ME	Single-end
FLL57MK	L	FLL	36	11.5	37	2.3	10	990	6.2	MK	
FLL120MK	L	FLL	40	10.0	40	2.3	10	2200	3.3	MK	
FLL200IB-1 ^{*1}	L	FLL	42.5	13.0	35	1.5	10	4800	1.6	IB	
FLL200IB-2 ^{*1}	L	FLL	42.5	11.0	34	2.3	10	4800	1.6	IB	Single-end
FLL200IB-3 ^{*1}	L	FLL	42.5	11.0	34	2.6	10	4800	1.6	IB	
FLL300IL-1	L	FLL	44.5	13.0	45	0.9	10	6000	1.0	IL	
FLL300IL-2	L	FLL	44.5	12.0	44	1.8	10	6000	1.0	IL	
FLL300IL-3	L	FLL	44.5	10.0	42	2.6	10	6000	1.0	IL	Single-end
FLL400IK-2	L	FLL	46.5	12.0	46	1.96	12	4000	1.3	IK	
FLL400IK-2C	L	FLL	46.0 ^{*2}	13.0 ^{*3}	45	2.17	12	1500	1.3	IK	
FLL410IK-3C	L	FLL	46.0 ^{*2}	13.0 ^{*3}	52	2.6	12	3000	1.3	IK	
FLL410IK-4C	S	FLL	46.0 ^{*2}	11.5 ^{*3}	44	3.6	12	3000	1.0	IK	Single-end
FLL600IK-2	L	FLL	48.0	13.5	45	1.96	12	4000	0.8	IK	
FLL310IQ-3A	L	FLL	45.0	9.0	40	2.7	12	7000	1.0	IQ-A	
FLL400IP-2	L	FLL	45.5	10.0	44	1.96	12	2000	1.0	IP	
FLL400IP-3	L	FLL	45.5	9.0	43	2.5	12	2000	1.0	IP	Single-end
FLL600IQ-2	L	FLL	48.0	10.5	43	1.96	12	4000	0.8	IQ-A	
FLL600IQ-2C	L	FLL	48.0 ^{*2}	12.0 ^{*3}	51	2.17	12	1500	0.8	IQ-A	
FLL600IQ-3	L	FLL	48.0	10.0	43	2.7	12	4000	0.8	IQ-A	
FLL800IQ-2C	L	FLL	49.0 ^{*2}	11.0 ^{*3}	50	2.17	12	2000	0.8	IQ-A	Push-Pull
FLL810IQ-3C	L	FLL	49.0 ^{*2}	12.0 ^{*3}	50	2.6	12	5000	0.8	IQ-B	
FLL810IQ-4C	S	FLL	49.0 ^{*2}	9.5 ^{*3}	45	3.6	12	5000	0.8	IQ-B	
FLL1200IU-2	L	FLL	50.8 ^{*2}	11.0 ^{*3}	44	1.96	12	5000	0.6	IU	
FLL1200IU-3	L	FLL	50.8 ^{*2}	11.0 ^{*3}	44	2.5	12	5000	0.6	IU	Push-Pull
FLL1500IU-2C	L	FLL	51.8 ^{*2}	12.0 ^{*3}	48	2.17	12	4000	0.55	IU	
FLL2400IU-2C	L	FLL	53.8 ^{*2}	11.5 ^{*3}	-	2.17	12	6000	0.45	IU	

Part Number	Frequency Band	Series	P1dB Typ. (dBm)	G1dB Typ. (dB)	η_{add} Typ. (%)	Frequency (GHz)	VDS Typ. (V)	IDS(DC) Typ. (mA)	Rth Typ. (°C/W)	Outline/Package Code	Feature
FLC317MG-4 ^{*1}	C	FLC	34.8	9.5	37	4.2	10	720	8	MG	General-use
FLC097WF	C	FLC	28.8	8.5	35	6	10	180	25	WF	
FLC167WF	C	FLC	31.8	7.5	35	6	10	360	15	WF	
FLC257MH-6 ^{*1}	C	FLC	34	9	36	6.4	10	600	8	MH	
FLC057WG	C	FLC	27	9	38	8	10	120	27	WG	
FLC107WG	C	FLC	30	8	36	8	10	240	16	WG	
FLC257MH-8 ^{*1}	C	FLC	34	8	35	8.5	10	600	8	MH	
FLX107MH-12 ^{*1}	X	FLX	30	7.5	33	12.5	10	240	15	MH	
FLX207MH-12 ^{*1}	X	FLX	32.5	7	28	12.5	10	480	10	MH	
FLK017WF	Ku	FLK	20.5	7.5	26	14.5	10	36	65	WF	
FLK027WG	Ku	FLK	24	7	32	14.5	10	60	40	WG	
FLK057WG	Ku	FLK	27	7	32	14.5	10	120	20	WG	
FLK107MH-14 ^{*1}	Ku	FLK	30	6.5	31	14.5	10	240	15	MH	
FLK207MH-14 ^{*1}	Ku	FLK	32.5	6	27	14.5	10	480	10	MH	

*1: Partially Input/Output Matched *2: Pout *3: GL *4: Plastic Mold Package Note: Tc(op)=+25°C

Small Signal GaAs FETs

GaAs FETs (Chip)

The FSU/FSX series are GaAs FETs that are designed for medium output power amplifier and oscillator applications with a wide dynamic range up to X-band frequencies. Tape and reel is available for both LP/LG packages.

Features

- Medium Power: P1dB = 15 to 24.5dBm
- High Gain: G1dB = 8 to 19dB
- High Reliability
- Hermetic Metal/Ceramic Packages (WF/LG)

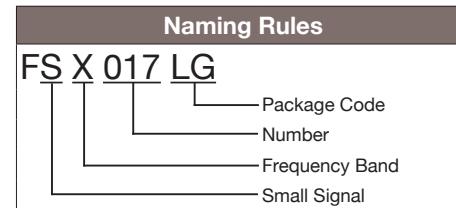

Specifications

Part Number	P1dB Typ. (dBm)	G1dB Typ. (dB)	Measurement Conditions 1			Noise figure NF Typ. (dB)	Associated gain Gas Typ. (dB)	Measurement Conditions 2			Outline/ Package Code	Feature/ Application
			Frequency f (GHz)	Drain Voltage VDS (V)	Drain Current IDS (mA)			Frequency f (GHz)	Drain Voltage VDS (V)	Drain Current IDS (mA)		
FSU01LG	20	19	2	6	40	0.5	18.5	2	3	10	LG *	Medium Power
FSU02LG	23	17	2	6	80	1.5	17.5	2	3	20	LG *	
FSX027WF	24.5	10	8	8	77	2.5	9.5	8	3	30	WF	Medium Power
FSX017WF	21.5	11	8	8	39	2.5	10.5	8	3	10	WF	
FSX017LG	16	8	12	4	30	-	-	-	-	-	LG *	

*: FSU01LG, FSU02LG, FSX017LG are all in LG-pkg with short lead.
Note: Tc (op) = +25°C



Features

- High Gain, High Frequency Chip

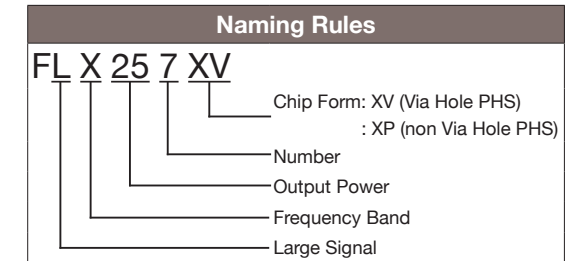

Specifications

Part Number	1dB Compression Power P1dB (dBm)	1dB Compression Gain G1dB (dB)	Power Added Efficiency η_{add} (%)	Frequency f (GHz)	Drain Voltage VDS (V)	Drain Current IDS (mA)	Application
FSX017X	21.5	11	42	8.0	8	38	X-band Amplifier
FSX027X	24.5	10	41	8.0	8	77	
FLX257XV	33.5	7.5	31	10.0	10	600	C-band Amplifier
FLC087XP	28.5	7	31.5	8.0	10	180	
FLC157XP	31.5	6	29.5	8.0	10	360	
FLC307XP	34.8	9.5	37	4.0	10	720	Ku-band Amplifier
FLK017XP	20.5	8	26	14.5	10	36	
FLK027XP	24	7	32	14.5	10	60	
FLK027XV	24	7	32	14.5	10	60	
FLK057XV	27	7	32	14.5	10	120	
FLK107XV	30	6.5	31	14.5	10	240	
FLK207XV	32.5	6	27	14.5	10	480	

X: Conventional Chip, XP: PHS (Plated Heat Sink), XV: Via Hole PHS

GaAs HEMTs (High Electron Mobility Transistors)

The HEMT series of products was developed by SEDI for a wide range of general purpose applications including, but not limited, to DBS converters, Handsets, Base Station, Radio-Telescope and many other applications where low-noise and gain is required. SEDI has a full lineup of HEMT products specified for applications in the 4GHz to 12GHz frequency range.

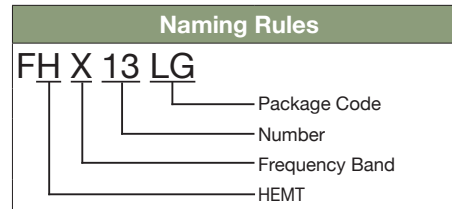

Specifications

Part Number	Noise figure NF Typ. (dB)	Associated Gain Gas Typ. (dB)	Drain Voltage VDS (V)	Drain Current IDS (mA)	Frequency f (GHz)	Outline/Package Code	Application
FHC40LG	0.3	15.5	2	10	4	LG	CS Front-end, TVRO, Handyphone BTS
FHC30LG	0.35	14.5	2	10	4	LG	
FHX76LP	0.4	13.5	2	10	12	LP	BS/CS LNA
FHX13LG	0.45	13.0	2	10	12	LG	
FHX14LG	0.55	13.0	2	10	12	LG	
FHX04LG	0.75	10.5	2	10	12	LG	
FHX05LG	0.9	10.5	2	10	12	LG	
FHX06LG	1.1	10.5	2	10	12	LG	
FHX35LG	1.2	10.0	3	10	12	LG	Low Noise Amp, Mixer, GPS
FHX35LP	1.2	10.0	3	10	12	LP	

Part Number	Noise figure NF Typ. (dB)	Associated Gain Gas Typ. (dB)	Drain Voltage VDS (V)	Drain Current IDS (mA)	Frequency f (GHz)	Application
FHX13X	0.45	13	2	10	12	Low Noise Amp, DBS LNB
FHX14X	0.55	13	2	10	12	
FHX04X	0.75	10.5	2	10	12	
FHX05X	0.9	10.5	2	10	12	
FHX06X	1.1	10.5	2	10	12	
FHX45X	0.55	12	2	10	12	
FHX35X	1.2	10	2	10	12	

X: Conventional Chip



Wireless Devices Package

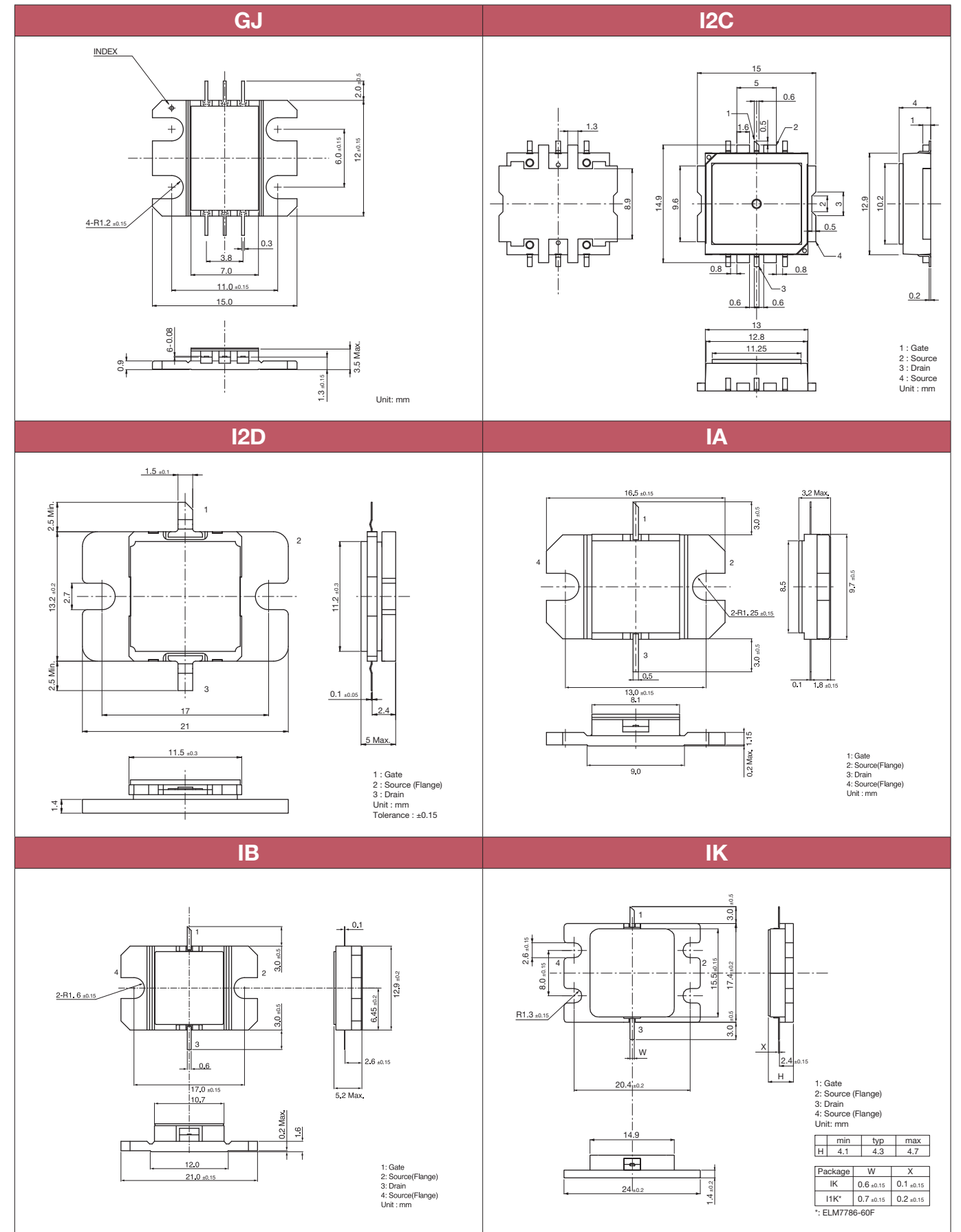

Wireless Devices Package

Wireless Devices Package

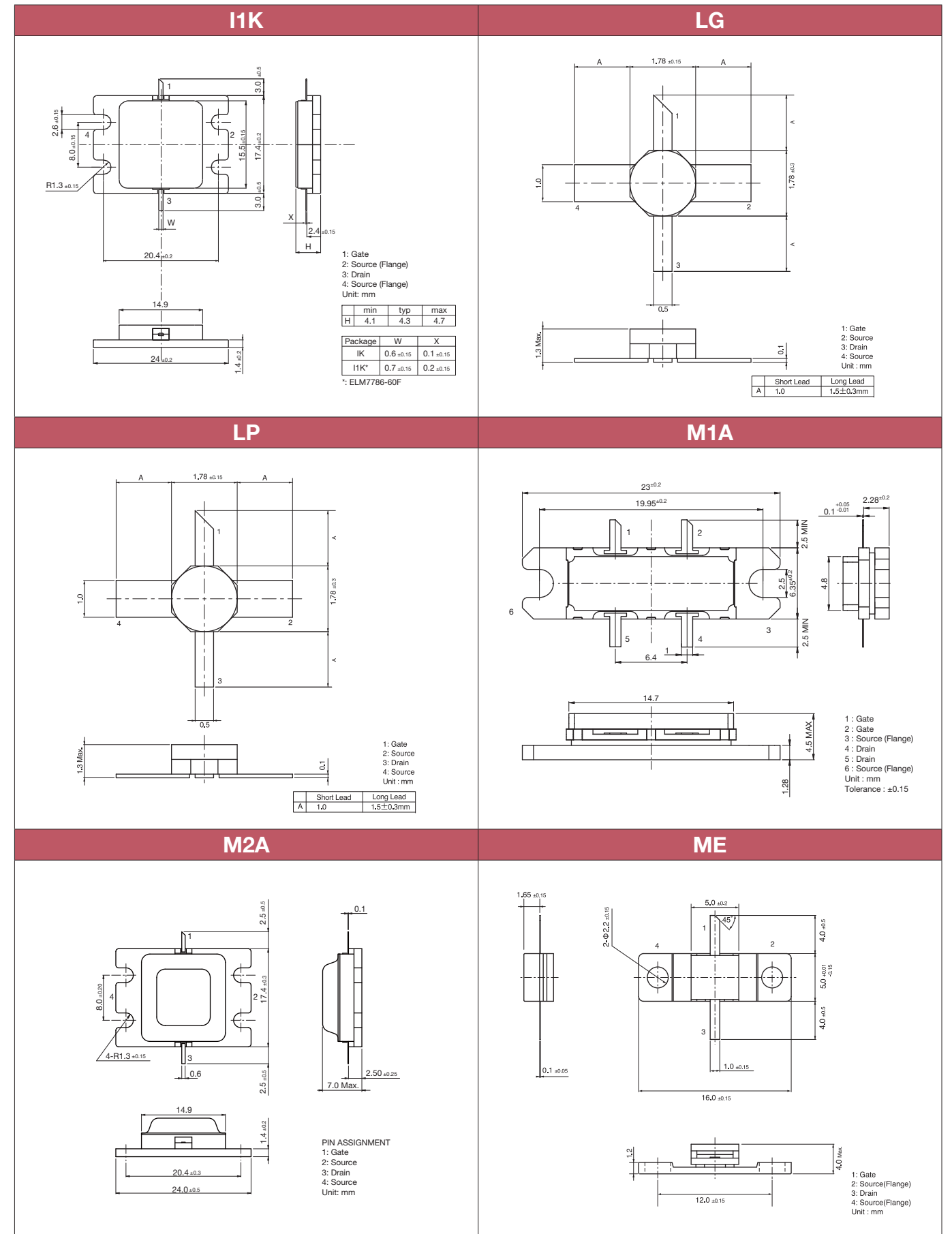
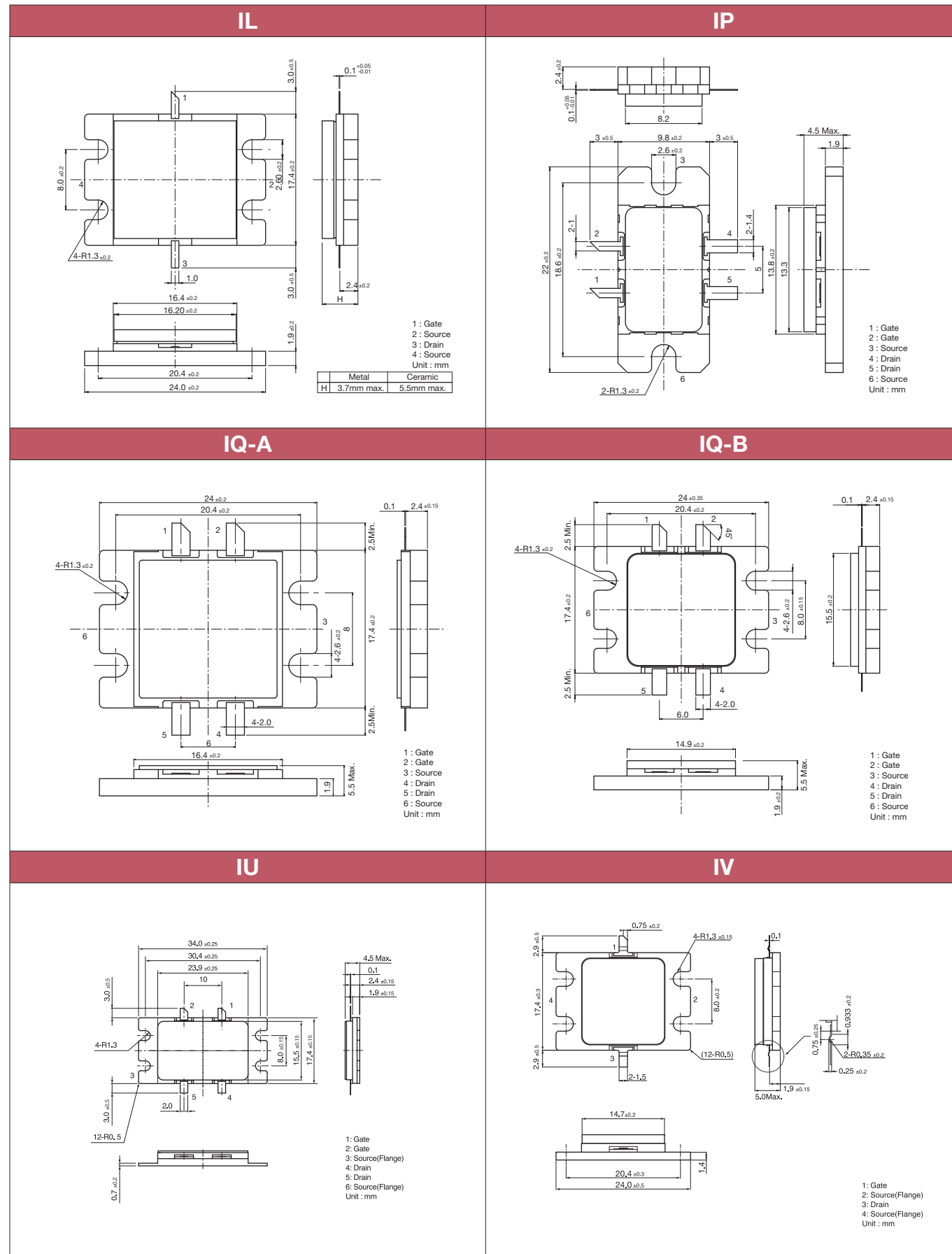

Wireless Devices Package

Wireless Devices Package

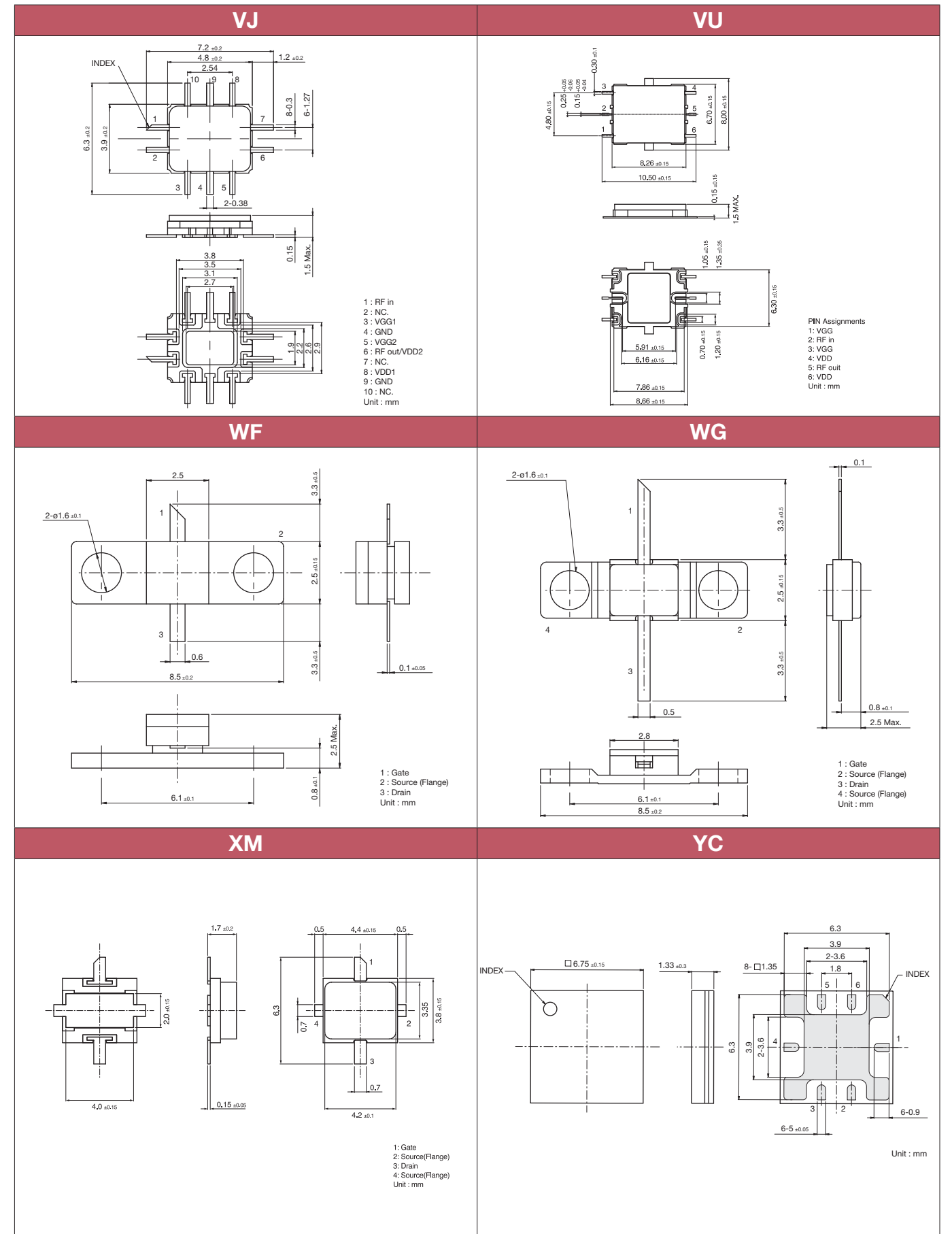
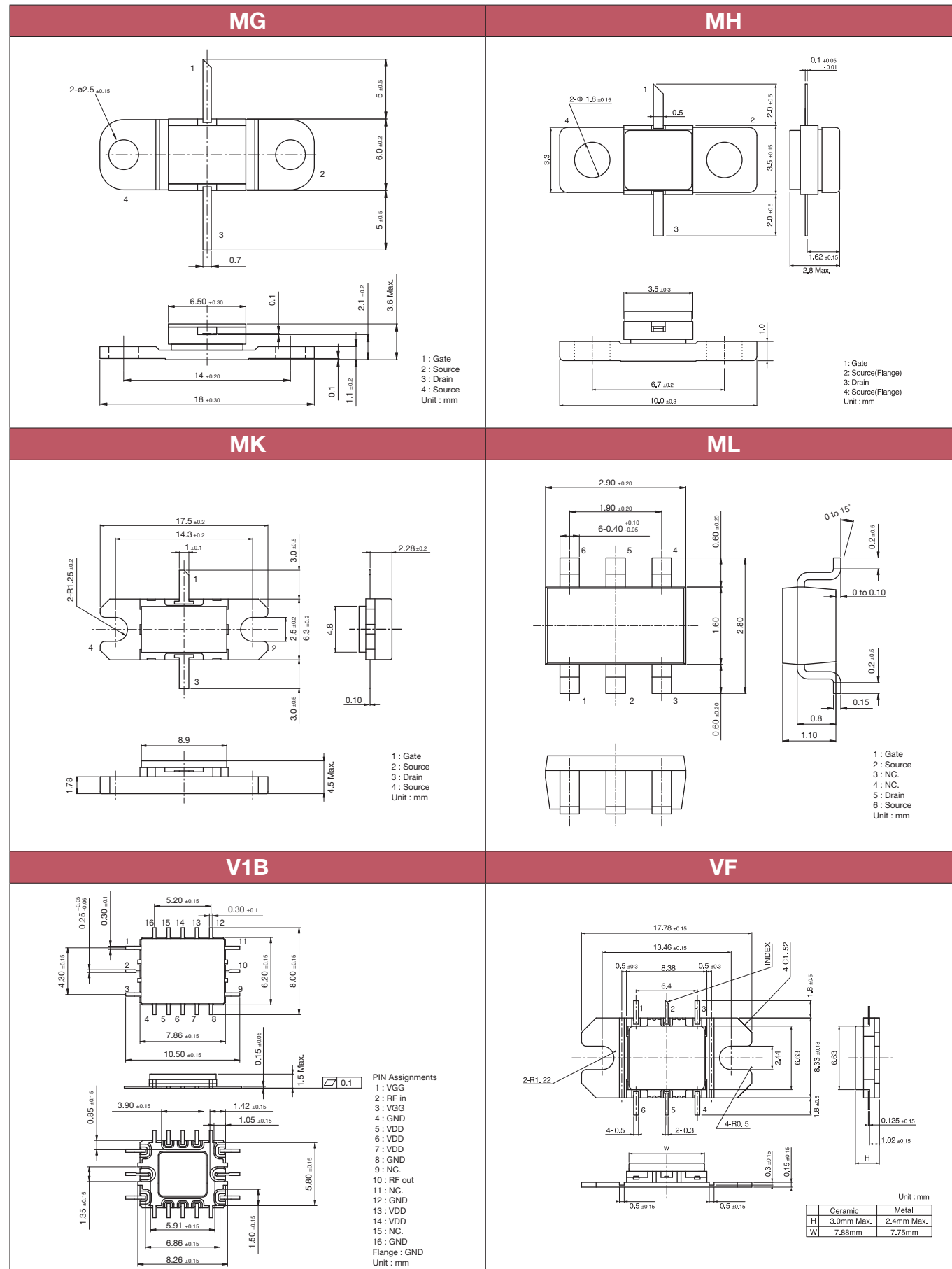

Wireless Devices Package

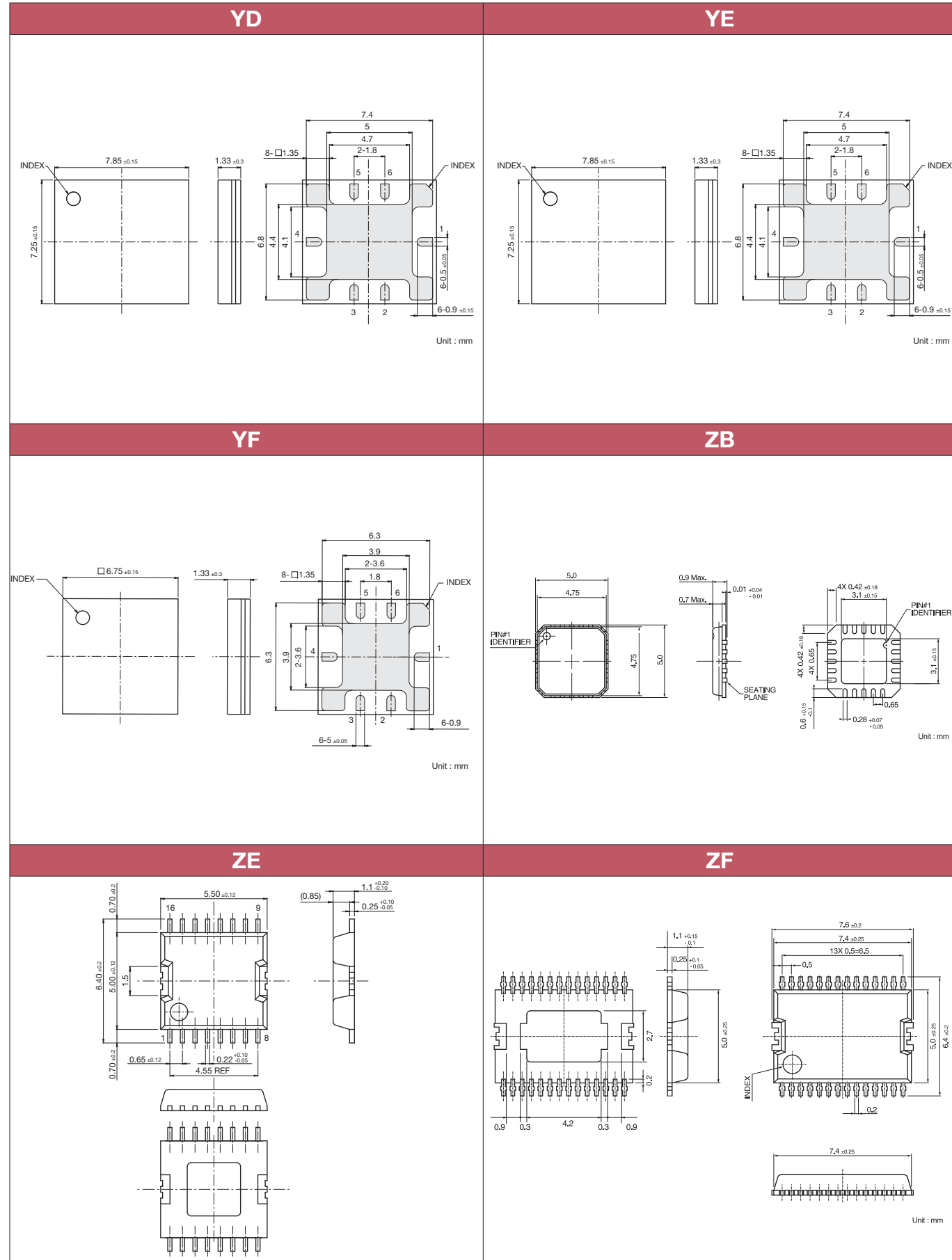

Wireless Devices Package

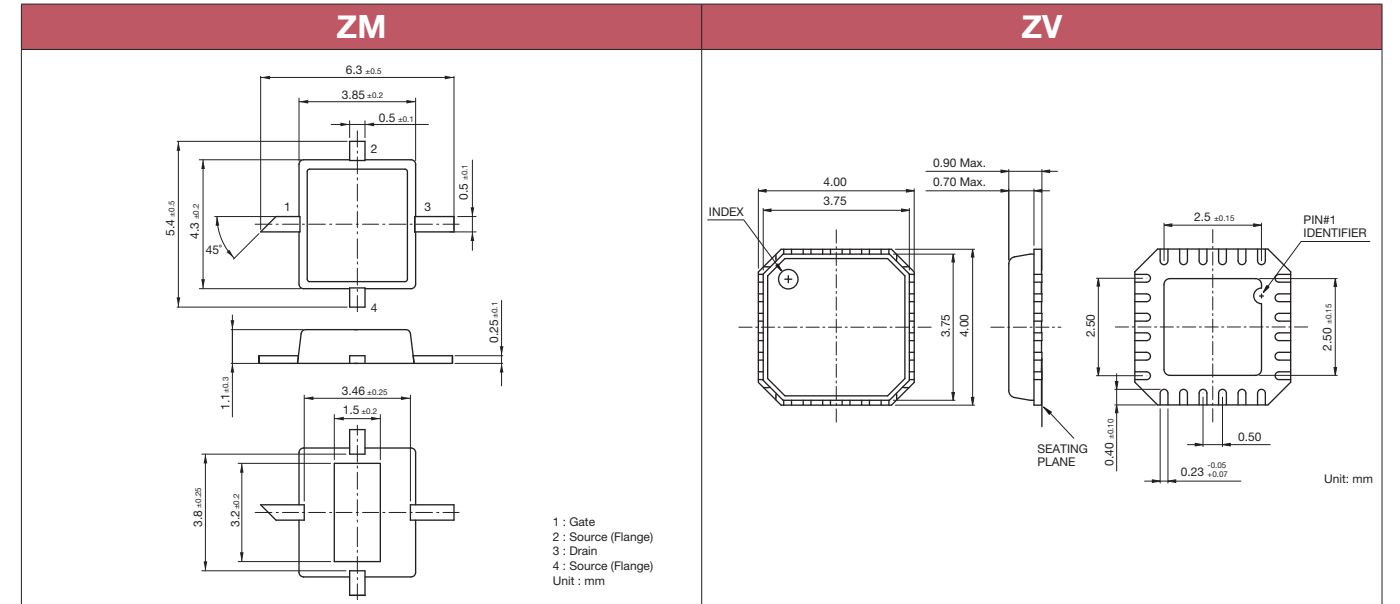

Corporate Quality Assurance

Sumitomo Electric Device Innovations strives to achieve the highest quality and reliability performance on all the products it supplies. This is accomplished through a systemic approach that emphasizes quality at every stage of product development through the manufacturing process. Quality is built into the product from design to wafer fabrication, test, and assembly. Sumitomo Electric Device Innovations has a Quality Management System that is certified to ISO9000 (ISO9001: 2000). This system assures customers the highest quality product with long term reliability required for their applications.

Quality Management

◆ ISO9001 Record

Sep. 1993	ISO9002 (Fujitsu Quantum Devices)
Nov. 1998	ISO9001
Sep. 2003	ISO9001: 2000
Apr. 2004	Eudyna Device Inc.
Oct. 2004	Expansion to Yokohama Factory
Oct. 2005	Expansion to Eudyna Microwave Assembly



Environmental Management

◆ ISO14001 Record

Aug. 1998	ISO14001
Aug. 2004	Expansion to Eudyna Microwave Assembly(Kofu)
Aug. 2007	Expansion to Eudyna Microwave Assembly(Matsushiro)
Aug. 2009	Sumitomo Electric Device Innovations



For Safety, Observe the Following Procedures Environmental Management

- Do not put this product into the mouth.
- Do not alter the form of this product into a gas, powder, or liquid through burning, crushing, or chemical processing as these by-products are dangerous to the human body if inhaled, ingested, or swallowed.
- Respect all applicable laws of the country when discarding this product.
This product must be disposed in accordance with methods specified by applicable hazardous waste procedures.

Any information, such as descriptions of a function and examples of application circuits, in this document are presented solely as a reference for the purpose to show examples of operations and uses of Sumitomo Electric Device Innovations semiconductor device(s); Sumitomo Electric Device Innovations does not warrant the proper operation of the device(s) with respect to its use based on such information. When the user develops equipment incorporating the device(s) based on such information, they must assume full responsibility arising out of using such information. Sumitomo Electric Device Innovations assumes no liability for any damages whatsoever arising out of the use of the information.

Any information in this document, including descriptions of function and schematic diagrams, shall not be construed as a license for the use or exercise of any intellectual property right, such as patent right or copyright, or any other right of Sumitomo Electric Device Innovations or any third party nor does Sumitomo Electric Device Innovations warrant non-infringement of any third-party's intellectual property right or other right by using such information. Sumitomo Electric Device Innovations assumes no liability for any infringement of the intellectual property rights or other rights of third parties which would result from the use of information contained herein.

The products described in this document are designed, developed and manufactured as contemplated for general use, including, without limitation, ordinary industrial use, general office use, personal use, and household use, but are not designed, developed and manufactured as contemplated (1) for use accompanying fatal risks or dangers that, unless extremely high safety is secured, could have a serious effect to the public, and could lead directly to death, personal injury, severe physical damage or other loss (i.e., nuclear reaction control in nuclear facility, aircraft flight control, air traffic control, mass transport control, medical life support system, missile launch control in weapon system), or (2) for use requiring extremely high reliability (i.e., submersible repeater and artificial satellite).

Please note that Sumitomo Electric Device Innovations will not be liable to the user and/or any third party for any claims or damages arising from the aforementioned uses of the products.

Any semiconductor devices have an inherent chance of failure. You must protect against injury, damage or loss from such failures by incorporating safety design measures into your facility and equipment such as redundancy, fire protection, and prevention of excessive current levels and other abnormal operating conditions.

If any products described in this document represent goods or technologies subject to certain restrictions on export under the Foreign Exchange and Foreign Trade Law of Japan, the prior authorization of the Japanese government will be required for export of those products from Japan.