

Hydronix

Fast Response, Linear Temperature Sensor
for Concrete Mixers and Aggregate Bins

Thermo-Tuff



THE ORIGINAL – THE LEADERS – THE BEST

Temperature Measurement

The Thermo-Tuff is a low cost, fast response, high precision, linear temperature sensor that has been designed to be used in the harshest of environments such as concrete mixers and aggregate bins. This sensor outclasses its rivals by taking advantage of high speed, high accuracy electronics, thermally isolated from their surroundings to achieve the fastest possible temperature response.

Technical Information

Construction

Body: Stainless Steel.

Sensing Head: Hardened Steel.

Fixing

Bins and Silos: Install in the wall of the bin using the Extension Mounting Sleeve and Collar.

Mixers: Install in the floor of the mixer using the Standard Mounting Collar.

Measurement Range

0-80 degrees C.

Response Time

Installed T90: Industry leading 56 seconds.

Power Supply

The sensor is powered by the 4-20mA current loop.

Analogue Output

Continuous 4-20mA signal, scaled to read between 0 and 80 degrees C.

Cable

Supplied with 4 metre two core screened cable.

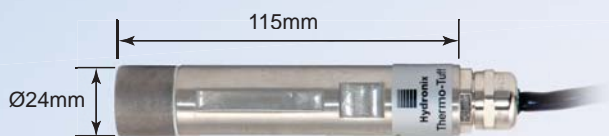

Standard Mounting Collar

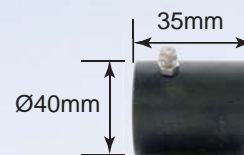

Extension Mounting Sleeve and Collar



Mixer Installation

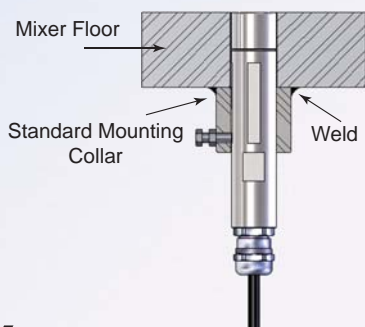

Bin Installation

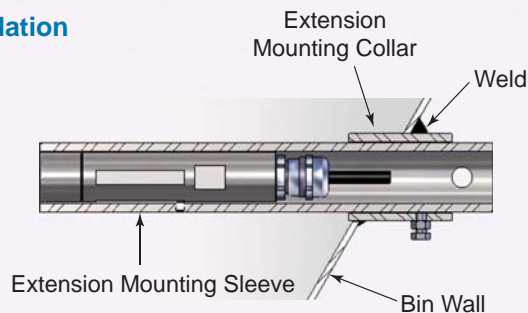

Hydronix

Head Office - United Kingdom:

Tel: +44 (0)1483 468900

Fax: +44 (0)1483 468919

Email: enquiries@hydronix.com

Central Europe & Southern Africa:

Tel: + 49 2563 4858

France:

Tel: + 33 (0) 652 04 89 04

America, Spain & Portugal:

Tel: 888-887-4884 (toll free)

or +1 231-439-5000

Part Number

Description

TT01	Thermo-Tuff Sensor
0310	Standard Mounting Collar
0320	Extension Mounting Sleeve and Collar

www.hydronix.com