

## Engineering Note

Hydronix Limited, 7 Riverside Business Centre, Walnut Tree Close, Guildford,  
Surrey GU1 4UG, England

☎ +44 (0)1483 468900 📠 +44 (0)1483 468919

Title:	Compatibility of HP02 with Alkon 7102 Moisture Probe
Document reference (DRC):	EN0030
Last updated:	V 1.0 05/06/01
Products affected:	HP02
Author:	C.I.Nicholls
Search keywords:	
Summary:	A method is described to ensure swap out compatibility between the HP02 and the Alkon 7102/ 9102

### Contents

I - Summary

II - How to connect the HP02:

1. To an Alkon 8191 Moisture display
2. Directly to a control/PLC/PC

III – How to Adjust HP02 Gain and offset to be identical with Alkon Default

### I - Summary

- A Hydronix HP02 can be used as a swap out replacement for Alkon 7102 moisture sensor. using only standard Hydronix parts and configurations (See Figure 2, 3).
- The HP02 sensor may be connected to the Alkon 8191 moisture display or connected directly to a PLC or PC
- Using the default calibrations of the two sensors results in maximum discrepancy of 0.3% over the range 0% moisture to 12 % moisture. (See Fig 1)
- Even this small discrepancy can be eliminated by simple adjustments to the HP02 calibration constants if required (See Section III)

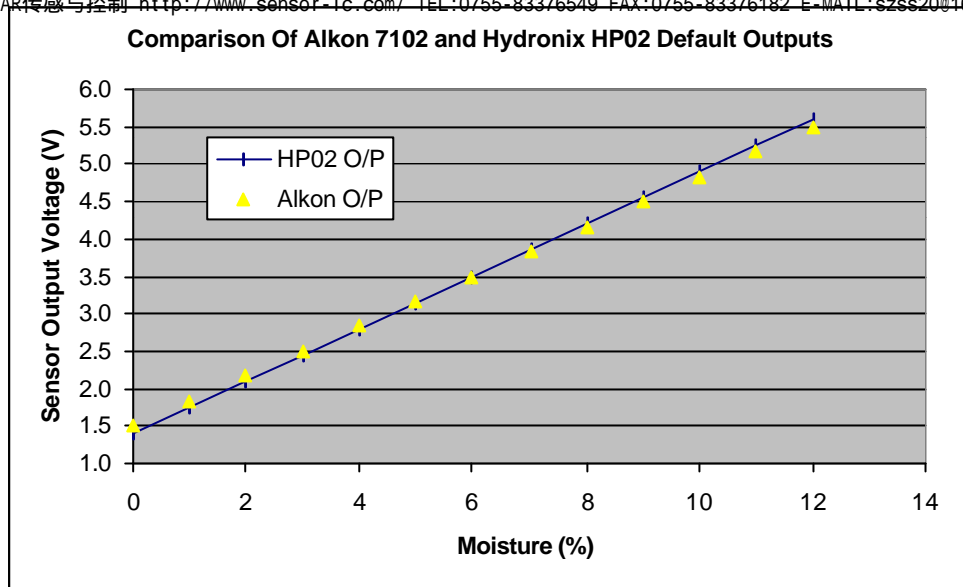

Figure 1 : Comparison of Default Alkon Calibration Against Default Hydronix Calibration

## II - How To Connect the Hydronix HP02 to reproduce the Alkon Sensor Output

Both Alkon and Hydronix aggregate moisture sensors provide an analogue signal which is proportional to the sample moisture content.

By default, the **Alkon Probe** output voltage is  $V_{out} = 0.33 * \text{moisture}(\%) + 1$

The offset value ( 1 in this case) is adjustable via the zero pot on the front panel of the display unit.

The default **HP02** calibration when using a compatibility cable is:

$$V_{out} = 0.35 * \text{moisture}(\%) + 1.4$$

Since the Alkon offset value is arbitrary (it depends upon the setting of the zero pot on the display front panel) Fig1. assumes that the two curves are identical at 6% moisture. With this assumption the difference between the two default calibrations varies from  $-0.3\%$  at 0% moisture to  $+0.3\%$  at 12 % moisture. If required, this discrepancy can be further reduced by minor adjustments to the HP02 calibration constants as described in section III below.

The following sections show how to connect an HP02 to replicate the output of an Alkon sensor.

## 1. Connecting HP02 to an Alkon 8191 Moisture Display

The power supply in the Alkon 8191 display unit produces 12 V at 120mA, which is insufficient power to operate the HP02. Therefore an external power supply must be used to power the HP02. Any 1A DC power supply with an output between 12 and 30V may be used (e.g. Hydronix part no. 0115). Connections should be made as shown below.

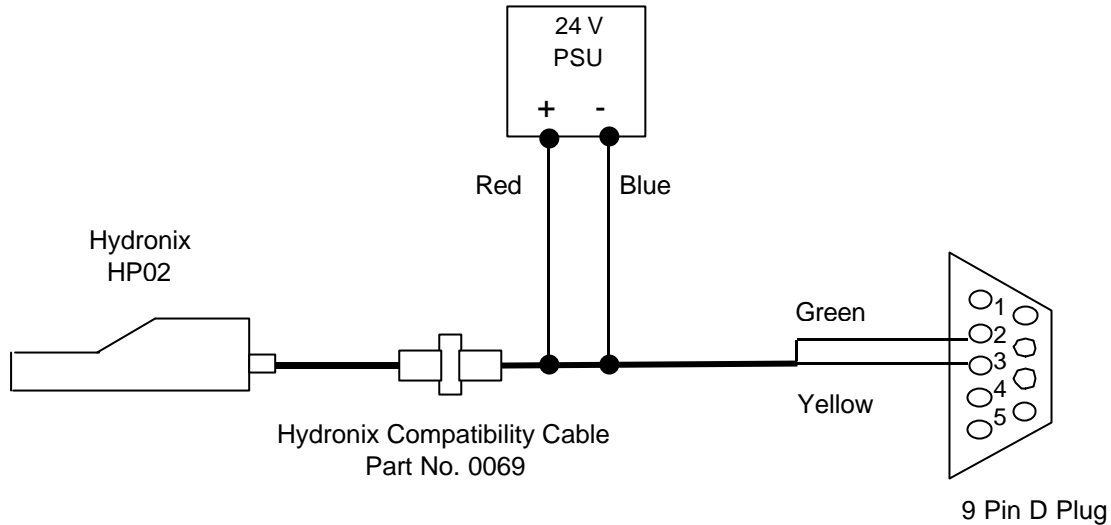

**Figure 2 : How to Connect HP02 to Alkon 9102 Display Unit**

Install the HP02 in the sand/aggregate bin as described in the HP02 User guide.

Then, with the system connected as in Fig 2 above, adjust the Zero pot on the front of the Alkon display unit as described in the 'Normal Calibration Procedure' section of the Alkon moisture system manual.

For those without a manual, briefly this procedure is:

1. Open the feed gate for a couple of seconds to stabilise the sand flow and then take two or three samples (1-2 Kg each) of sand flowing past the sensor.
2. Bake out the sand samples in an oven or a microwave to measure the moisture content. The moisture content can be calculated as
 
$$\% \text{moisture} = (\text{wet weight} - \text{dry weight}) / \text{dry weight} \times 100$$
3. If the three bake out tests agree with each other to within ~ 0.3% average the results, else repeat from step 1.
4. Adjust the zero pot on the front panel of the Display unit until the displayed moisture value agrees with the bake out result.
5. Open the sand gate again (the displayed moisture value may drop a little) and adjust the zero pot until the reading in flowing sand agrees with the bake out result (Clockwise to increase display value, counter clockwise to reduce display)
6. Switch 'Normal/Calibrate' switch to 'Calibrate' and adjust calibrate dial until display shows 2.0%.n Record dial setting. Turn dial until display shows 10.0%. Record setting.
7. Switch 'Normal/Calibrate' switch to 'Normal'

For most sands and aggregates this procedure should result in displayed moistures accurate to a few tenths of a percent.

## 2. Connecting HP02 Directly to a control PLC/PC

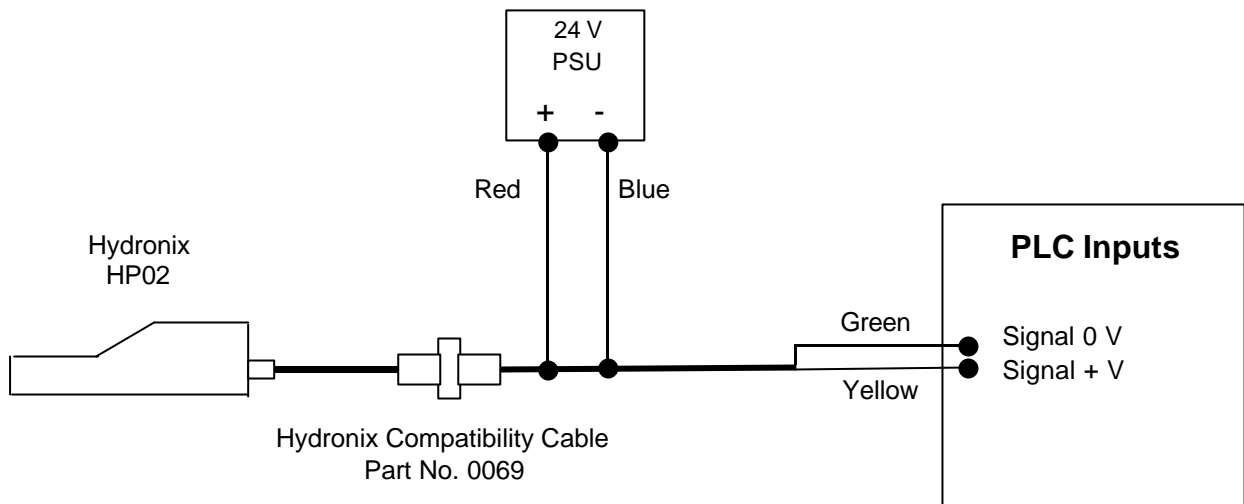

**Figure 3 : How to Connect HP02 to Directly to PLC/PC**

To connect the HP02 to a PLC or PC use any 4W DC power supply with an output between 12 and 30V (e.g. Hydronix part no. 0115). Connections should be made as shown above. Signal output will be a DC voltage which will vary between 0 & 10 V, dependent upon aggregate moisture level.

### III – How To Adjust The HP02 Output To Be Identical With The Alkon Default Output

Using the procedure described above should ensure that the difference between a moisture measurement obtained with a HP02 and one obtained with an Alkon 7102 should be no more than ~ 0.25% over the range 0-12% moisture. For most people this agreement will be easily close enough and no further calibration will be required.

However using the following additional procedure will ensure that the HP02 has an identical output to an Alkon probe in the unlikely event that a precise agreement is essential.

The default calibration assumed is that given in the Alkon manual (document No. 22530, revised March 1994) , i.e.

$$V_{out} = 0.33 * \text{moisture}(\%) + 1$$

- Connect the probe to a PC running the 'HydroLink' configuration software
- Select the 'Configuration' tab. (See figure 3 below)
- Press the 'Read' button at the bottom right of the screen
- At the top left of the screen ('User Calibration' frame) enter
  - 0.0000 for A
  - 0.1905 for B
  - -0.6667 for C

- At the top right of the screen ('Output' frame) select
  - Output type : 0-20mA (0-10V)
  - Output variable: Now Moisture %
- Enter the following values
  - Low %: 0.00
  - High % 20.00
- Press the 'Write' button at the bottom of the page to write these selections into the HP02's memory.
- After a couple of seconds a message informing you that the memory has been updated will appear. Click the OK button. The parameters shown in Figure 3 have now have now been permanently stored in the HP02 memory.
- **Note** : The values in the factory calibration frame will differ from those shown in Fig 3. **They should not be changed under any circumstances**

These value ensure that with a compatibility cable an HP02 will give a voltage output exactly equivalent to the voltage generated by an Alkon probe.

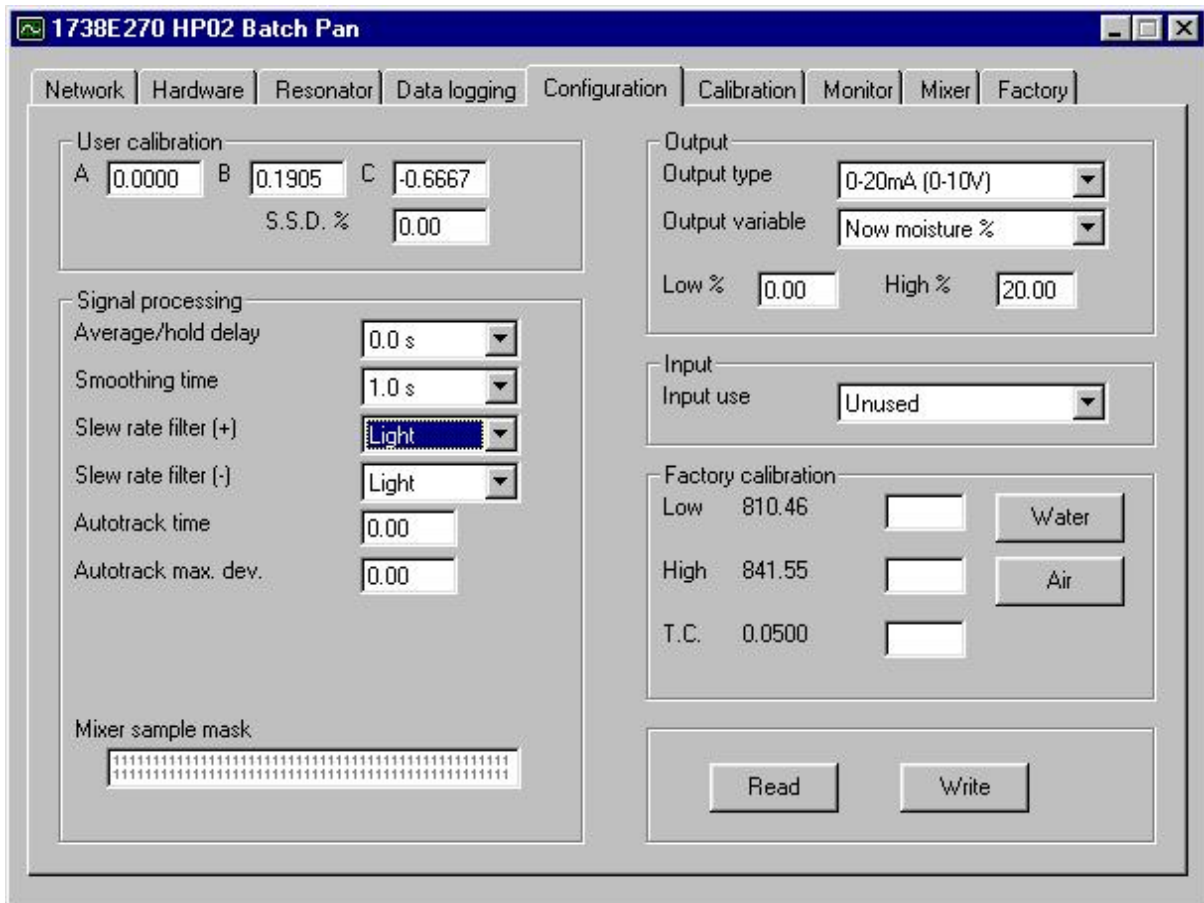

**Fig. 3 : Hydrolink Configuration Tab Showing Values to Enter.**