

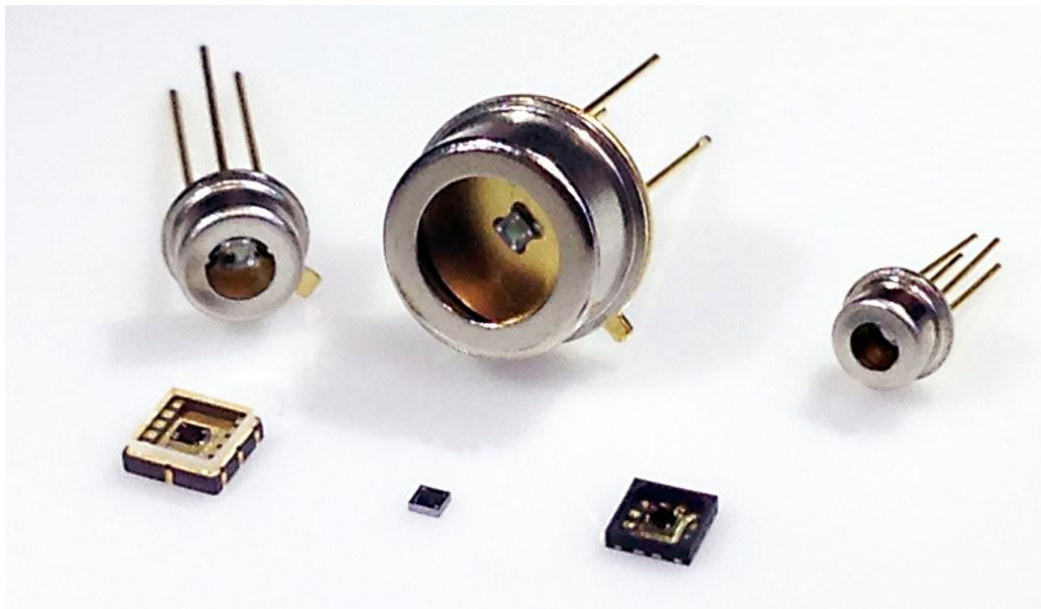

Infrared Sources and Micro-Hotplate Packaging Options

Barry Morris



All Cambridge CMOS Sensors (CCS) Infrared Sources and Micro-Hotplates are available with a bare die option to allow customers to integrate CCS technology into their own products and systems, but devices are also available in many varieties of packaging, including TO-style, and Surface Mount. Size limitations, however, mean that some devices cannot be offered in all packages – please see table below for availability.

Device	Bare Die	Micro-TO	TO46	TO39	LCC (3.8 x 3.8mm)	LCC (5 x 5mm)	QFN
CCSIRx09x & CCSMHx09x	✓	✓	✓	✓	✓	✓	✓
CCSIRx61x & CCSMHx61x	✓	✓	✓	✓	✓	✓	✓
CCSIRx79x & CCSMHx79x	✓	✗	✓	✓	✓	✓	✗
CCSIRx80x	✓	✗	✓	✓	✓	✓	✗
CCSMHx88x	✓	✗	✓	✓	✓	✓	✗

TO-Style Packages

CCS offers all of its devices in a range of TO-Style packages. Standards are Micro-TO, TO46, and TO39, but others are available on request. In general terms, CCS uses headers stamped from Ni-Fe alloys (typically Kovar or Ni42) which are then nickel plated before a final layer of gold is applied. The pins are manufactured from similar materials and are also nickel plated and gold coated. Pins are fitted through the header using high-quality glass to metal seals, but usually one pin is brazed directly to the header to act as an electrical ground. Grounded pins are referred to in the package specification as “+1”, ie a 3-pin package with one of the pins connected to the package is referred to as “2 + 1”.

The number of pins will depend on any circuit additions such as temperature sensing diodes, FET drivers, and/or IDE electrodes for resistive sensing applications – see examples below:

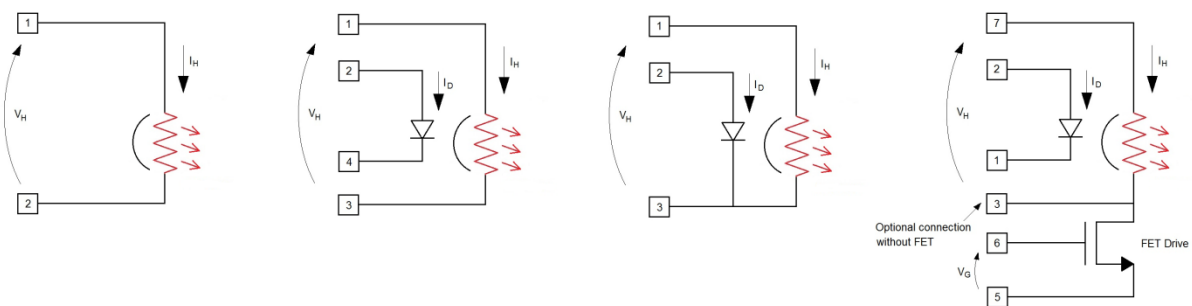

Once the IR Source or Micro-Hotplate has been bonded and connected to the header described above, a metal cap can then be fitted. Normally manufactured from similar materials to the header (but without the gold coating), this can be a complete, removable cap purely for physical protection, or a cap containing an opening in its top through which the infrared can travel. This opening can be left empty, or a lens and/or filter can be fitted (see separate Applications Notes). The cap itself can be welded to the header and, using the sealing of the lens/filter can create a completely sealed device.

“TO” -encapsulated Infrared Sources and Micro-Hotplates can be used in a variety of applications where mounting through-hole or using TO-sockets is preferred. Specifically, the Micro-TO package is almost identical in size to a standard infrared micro-bulb, meaning that there are very few design changes required in order to replace an existing micro-bulb with a CCS IR Source.

Dimensions, pin positions and tab location of standard TO packages are shown on the next page.

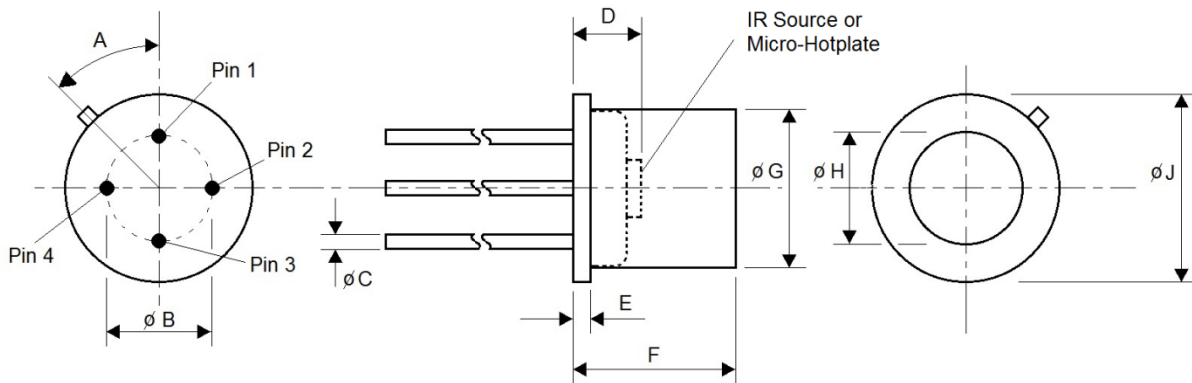

Package	A	B (mm)	C (mm)	D (mm)	E (mm)	F (mm)	G (mm)	H (mm)	J (mm)
TO39	45°	5.08	0.45	1.92	0.38	4.35	8.31	5.30	9.20
TO46	45°	2.54	0.45	1.55	0.25	2.70	4.70	2.55	5.40
Micro TO	-	1.80	0.30	1.28	0.38	2.30	3.10	1.80	4.10

Surface Mount Packages

To cater for today's increasing demand for surface mount technology, CCS now offers its devices in three popular styles of surface mount package: QFN, LCC (3.8mm x 3.8mm) and LCC (5mm x 5mm).

As with the TO-Style packages, once the IR Source or Micro-Hotplate has been bonded and connected into the housing, this can be left open, or a plain window or filter can be fitted (see separate Applications Notes). This window/filter can be sealed to the housing creating a completely sealed device.

The QFN package is manufactured from semiconductor grade plastic with a C-194F/H copper electroplated lead frame. Dimensions are shown below:

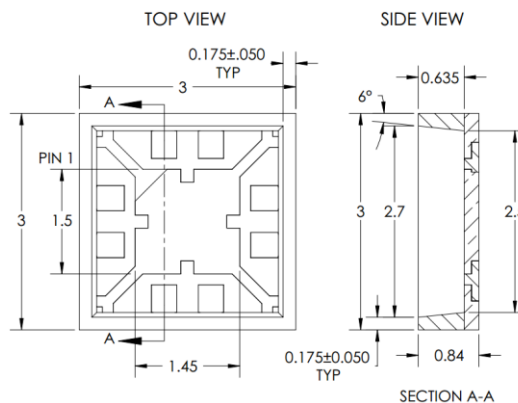

The recommended PCB layout for attaching the QFN package is shown below:

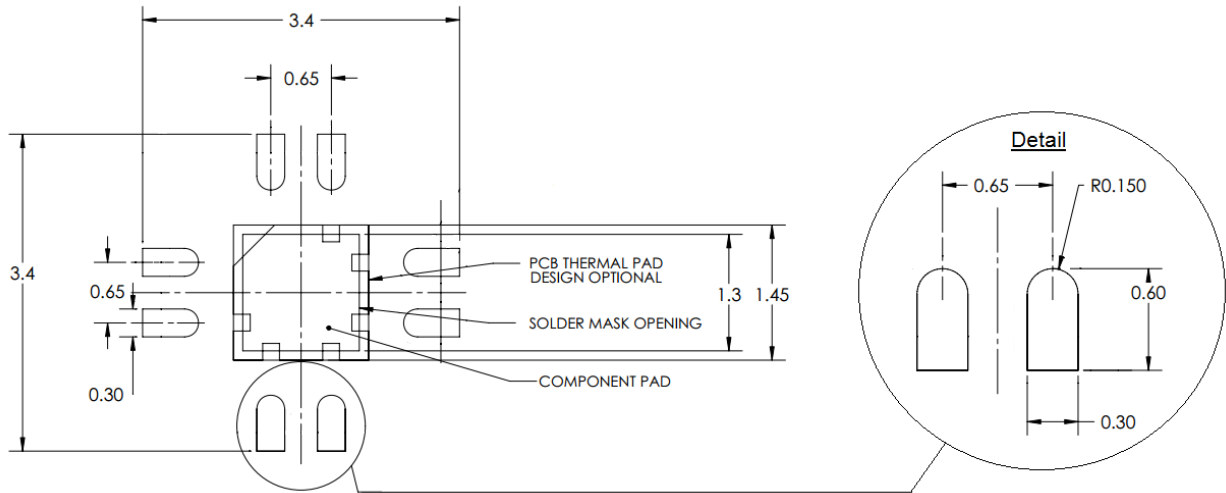

The LCC range of packages is manufactured from an Al₂O₃ ceramic. Dimensions as below:

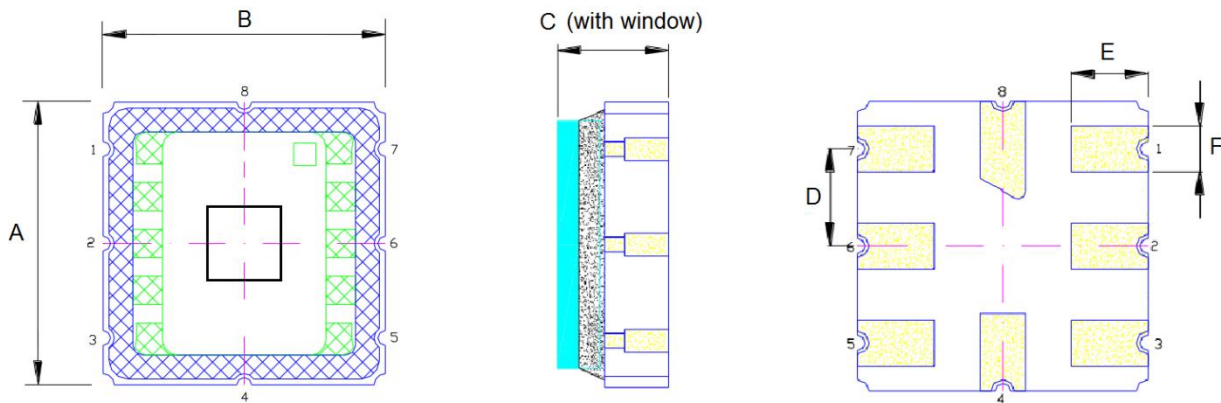

Package	A (mm)	B (mm)	C (mm)	D (mm)	E (mm)	F (mm)
LCC (3.8mm x 3.8mm)	3.8	3.8	1.45	1.27	1.00	0.60
LCC (5mm x 5mm)	5.0	5.0	2.00	1.27	1.12	0.64

The recommended PCB layout for attaching the QFN package is shown below:

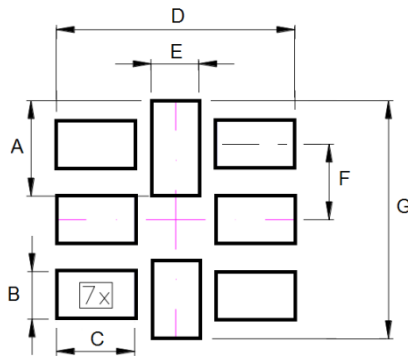

Package	A (mm)	B (mm)	C (mm)	D (mm)	E (mm)	F (mm)	G (mm)
LCC (3.8mm x 3.8mm)	1.60	0.80	1.30	4.0	0.80	1.27	4.0
LCC (5mm x 5mm)	2.28	0.84	1.47	5.2	0.84	1.27	5.2

For further information on any of the above, please contact Cambridge CMOS Sensors:

Tel: +44 1223 321905

email: sales@ccmoss.com

Many other Applications Notes are available from the CCS website: www.ccmoss.com