MSM7577

Voice Signal Level Control LSI

GENERAL DESCRIPTION

The MSM7577 is an LSI for Audio Signal Level adjustment for telephone set, etc. Conventionally, its circuit has been made within individual unit, such as amplifiers, resistors and switches. However, using this LSI allows for simple mounting and economically small space.

FEATURES

Receiving system

- Built-in electrical volume
Digital control (3 bit / 8 step)
- For transmission voice, with side tone route available.
- Mute function available.

Transmitting system

- Built-in operational amplifier for transmission signal level adjustment.
- Mute function available.
- Single +2.7 V to +5.25 V power supply
- Power down function
- Package:
16-pin plastic SOP (SOP16-P-300-1.27-K) (Product name : MSM7577MS-K)

APPLICATION

Cellular handset, cordless telephone, etc.

BLOCK DIAGRAM

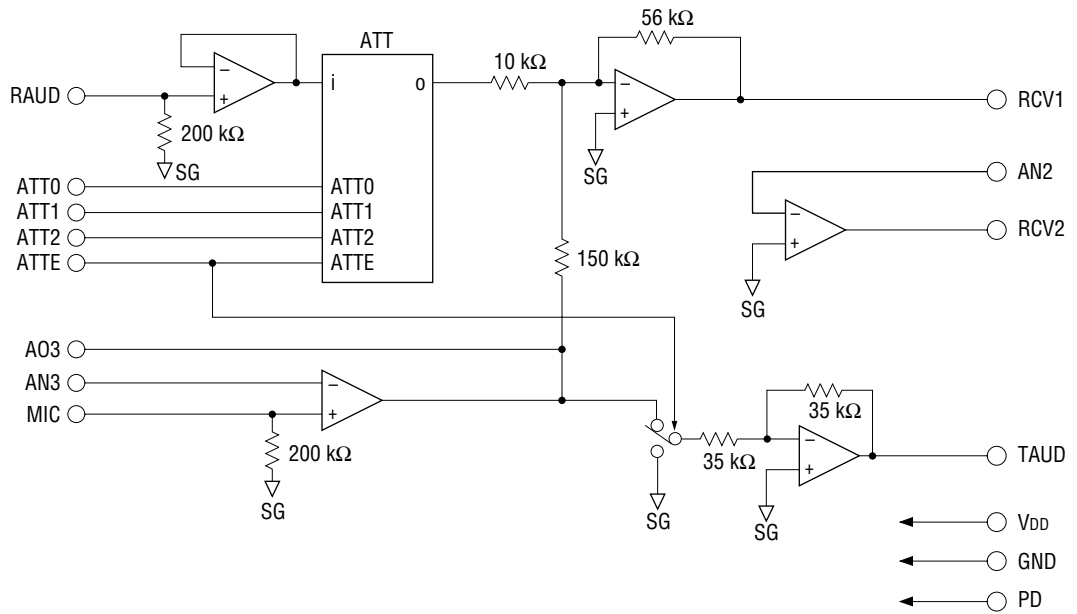

PIN CONFIGURATION (TOP VIEW)

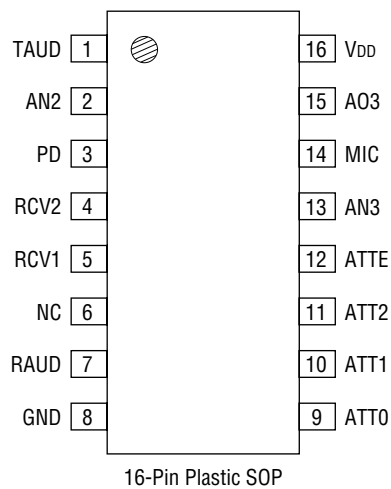

NC : No connect pin

PIN DESCRIPTION

Pin No.	Name	I/O	Description																																					
1	TAUD	0	Output pin of transmitting voice.																																					
2	AN2	I	Receive voice input. Gain control should be connected by a resistor between AN2 pin RCV2 pin.																																					
3	PD	1	Power down control. H : Power down L : Power on																																					
4	RCV2	0	Output pin of receiving voice. Gain control should be connected by a resistor between AN2 and RCV2 pin. RCV2 signal is opposite phase to RCV1 signal.																																					
5	RCV1	0	Receive voice input. RCV1 signal is opposite phase to RCV2 signal.																																					
6	NC	—	No Connection.																																					
7	RAUD	I	Receive voice input.																																					
8	GND	—	Ground (0 V).																																					
9	ATT0	I	Volume control.																																					
10	ATT1																																							
11	ATT2																																							
				<table border="1"> <thead> <tr> <th>ATT2</th> <th>ATT1</th> <th>ATT0</th> <th>Loss level (dB)</th> </tr> </thead> <tbody> <tr> <td>0</td> <td>0</td> <td>0</td> <td>0 ±0.3</td> </tr> <tr> <td>0</td> <td>0</td> <td>1</td> <td>-2 ±0.3</td> </tr> <tr> <td>0</td> <td>1</td> <td>0</td> <td>-4 ±0.3</td> </tr> <tr> <td>0</td> <td>1</td> <td>1</td> <td>-7 ±0.3</td> </tr> <tr> <td>1</td> <td>0</td> <td>0</td> <td>-10 ±0.3</td> </tr> <tr> <td>1</td> <td>0</td> <td>1</td> <td>-13 ±0.3</td> </tr> <tr> <td>1</td> <td>1</td> <td>0</td> <td>-16 ±0.3</td> </tr> <tr> <td>1</td> <td>1</td> <td>1</td> <td>-19 ±0.3</td> </tr> </tbody> </table>	ATT2	ATT1	ATT0	Loss level (dB)	0	0	0	0 ±0.3	0	0	1	-2 ±0.3	0	1	0	-4 ±0.3	0	1	1	-7 ±0.3	1	0	0	-10 ±0.3	1	0	1	-13 ±0.3	1	1	0	-16 ±0.3	1	1	1	-19 ±0.3
ATT2	ATT1			ATT0	Loss level (dB)																																			
0	0	0	0 ±0.3																																					
0	0	1	-2 ±0.3																																					
0	1	0	-4 ±0.3																																					
0	1	1	-7 ±0.3																																					
1	0	0	-10 ±0.3																																					
1	0	1	-13 ±0.3																																					
1	1	0	-16 ±0.3																																					
1	1	1	-19 ±0.3																																					
12	ATTE	I	Mute signal input. H : Mute mode L : Operating mode																																					
13	AN3	I	Gain control and frequency response control. Gain control should be controlled by a resistor between AN3 and A03.																																					
14	MIC	I	Input pin of Microphone signal.																																					
15	A03	0	Gain control and frequency response control. Gain control should be controlled by a resistor between AN3 and A03.																																					
16	V _{DD}	—	Power supply (+3 V).																																					

ABSOLUTE MAXIMUM RATINGS

Parameter	Symbol	Min.	Max.	Unit
Power Supply Voltage	V_{DD}	-0.3	+7.0	V
Digital Input Voltage	V_{IND}	-0.3	$V_{DD} + 0.3$	V
Analog Input Voltage	V_{INA}	-0.3	$V_{DD} + 0.3$	V
Storage Temperature	T_{STG}	-55	+150	°C

RECOMMENDED OPERATING CONDITIONS

Parameter	Symbol	Condition	Min.	Typ.	Max.	Unit
Operating Temperature	T_a	—	-20	25	70	°C
Power Supply Voltage	V_{DD}	V_{DD}	+2.7	+3.00	+5.25	V
Analog Output Load Resistance 1	R_{LA1}	TAUD	600	—	—	Ω
Analog Output Load Resistance 2	R_{LA2}	Except TAUD pin.	10	—	—	k Ω

ELECTRICAL CHARACTERISTICS

DC Characteristics

(Ta = -20°C to 70°C, V_{DD} = 2.7 V to 5.25 V)

Parameter	Symbol	Condition	Min.	Typ.	Max.	Unit
Power Supply Current	I _{DD}	V _{DD} = 3.0 V	—	1.2	2.4	mA
		*V _{DD} = 5.0 V	—	10.0	20	
Power Down Current	—	PD = V _{DD}	—	0.1	0.2	mA
Low Level Input Voltage	V _{IL}	ATT0 to ATT2 ATTE, PD	0	—	0.3 × V _{DD}	V
High Level Input Voltage	V _{IH}	ATT0 to ATT2 ATTE, PD	0.7 × V _{DD}	—	V _{DD}	V
Digital Input Leakage Current	I _{IL}	V _I = GND	-10	—	+10	μA
	I _{IH}	V _I = V _{DD}				
Analog Input Voltage Level	V _{IA}	RAUD, MIC AN2, AN3	—	—	1.2	V _{P-P}
Analog Input Resistance	R _{IA}	RAUD MIC	—	200	—	kΩ
Analog Output Level Range 1	V _{O1}	RCV1, RCV2, AO3 R _L = 5 kΩ (to SG level)	1.2	—	—	V _{P-P}
Analog Output Level Range 2	V _{O2}	TAUD R _L = 600 Ω (to SG level)	1.2	—	—	V _{P-P}

Analog Interface Characteristics

(Ta = -20°C to 70°C, V_{DD} = 2.7 V to 5.25 V)

Parameter	Symbol	Condition	Min.	Typ.	Max.	Unit
RX-AUDIO Path Gain	V _{RXA}	RAUD-RCV1 ATT = 0 dB ATTE = L	+14	+15	+16	dB
RX-AUDIO Loss Level (Mute)	L _{RXA}	RAUD-RCV1 RAUD = -20 dBV ATTE = 0 dB ATTE = L→H	40	—	—	dB
TX-AUDIO Loss Level	L _{TXA}	MIC-TAUD MIC = -20 dBV ATTE = L→H	40	—	—	dB
TX-AUDIO Path Gain	V _{TXA}	MIC-TAUD AO3 and AN3 are connected 600 Ω load resistance	-1.0	0	+1.0	dB
MIC Path Gain	V _{RTA}	MIC-RCV1 AO3 and AN3 are connected	-9.5	-8.5	-7.5	dB
ATT Establish Error	V _{ATG}	RAUD-RCV1 ATT0 to ATT2	-0.3	0	+0.3	dB
TX-AUDIO Distortion	—	MIC = -7.45 dBV fi = 1 kHz 600 Ω load resistance	—	—	8	%

PACKAGE DIMENSIONS

(Unit : mm)

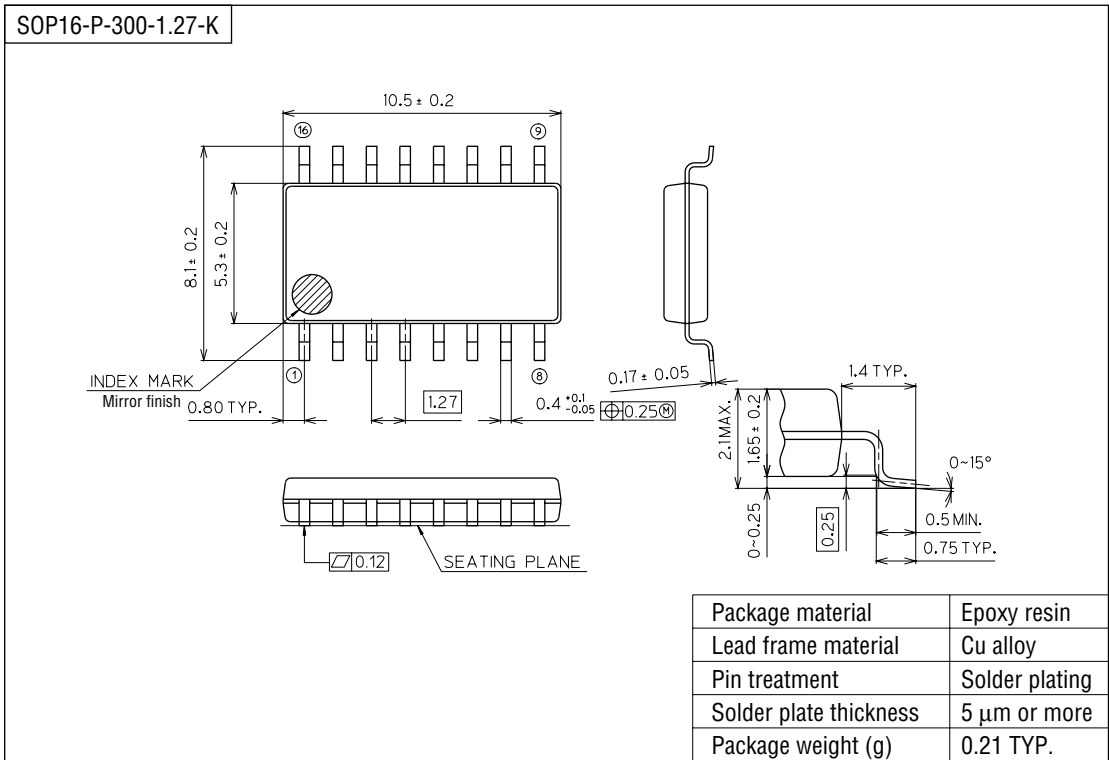

Notes for Mounting the Surface Mount Type Package

The SOP, QFP, TSOP, SOJ, QFJ (PLCC), SHP and BGA are surface mount type packages, which are very susceptible to heat in reflow mounting and humidity absorbed in storage. Therefore, before you perform reflow mounting, contact Oki's responsible sales person for the product name, package name, pin number, package code and desired mounting conditions (reflow method, temperature and times).