

---

**MSM63P238**

---

**4-Bit Microcontroller with Built-in 16K Word PROM, POCSAG Decoder, and Melody Circuit**

---

**GENERAL DESCRIPTION**

The MSM63P238 is a CMOS 4-bit microcontroller with a built-in POCSAG (Post Office Code Standardization Advisory Group) decoder, which employs Oki's original nX-4/250 CPU core. The MSM63P238 is a one-time-programmable ROM-version product having one-time PROM (OTP) as internal program memory.

The specifications of the MSM63P238 are equal to those of the MSM63238 except for electrical characteristics, packaging (only 80-pin flat package is available for the MSM63P238), and some functions.

**FEATURES**

The features of the MSM63P238 with an asterisk (\*) differ from those of the mask ROM-version MSM63238.

- Rich instruction set
  - 439 instructions
  - Transfer, rotate, increment/decrement, arithmetic operations, comparison, logic operations, mask operations, bit operations, ROM table reference, external memory transfer, stack operations, flag operations, branch, conditional branch, call/return, control.
- Rich selection of addressing modes
  - Indirect addressing of four data memory types, with current bank register, extra bank register, HL register and XY register.
  - Data memory bank internal direct addressing mode.
- Processing speed
  - Two clocks per machine cycle, with most instructions executed in one machine cycle.
  - Minimum instruction execution time : 61  $\mu$ s (@ 32.768 kHz system clock)
  - 1  $\mu$ s (@ 2 MHz system clock)
- Clock generation circuit
  - Low-speed clock : 32.768 kHz/38.4 kHz/76.8 kHz crystal oscillator
  - High-speed clock : 2 MHz (Max.) RC or ceramic oscillator select
- Program memory (PROM) space\*
  - 16K words
  - Basic instruction length is 16 bits/1 word
- Data memory space
  - 1K nibbles
- External data memory space
  - 64 Kbytes (expandable by using an I/O port)

- Stack level
  - Call stack level : 16 levels
  - Register stack level : 16 levels
- POCSAG decoder
  - Data rate : 512 bps/1200 bps/2400 bps
  - User frame : 3 types
  - User address : 6 types
  - Battery saving mode (for controlling intermittent operations of RF receiver)
- I/O ports
  - Input ports: Selectable as input with pull-up resistance/input with pull-down resistance/high-impedance input
  - Output ports: Selectable as P-channel open drain output/N-channel open drain output/CMOS output/high-impedance output
  - Input-output ports: Selectable as input with pull-up resistance/input with pull-down resistance/high-impedance input  
Selectable as P-channel open drain output/N-channel open drain output/CMOS output/high-impedance output
  - Can be interfaced with external peripherals that use a different power supply than this device uses.
  - Number of ports:
    - Input port : 1 port × 4 bits
    - Output port : 6 ports × 4 bits
    - Input-output port : 5 ports × 4 bits  
1 port × 2 bits
- Melody output function
  - Melody sound frequency : 529 to 2979 Hz
  - Tone length : 63 types
  - Tempo : 15 types
  - Note data : Resides in the program memory
  - Buzzer drive signal output : 4 kHz
- Reset function
  - Reset through RESET pin
  - Power-on reset
  - Reset by low-speed oscillation halt
- Battery check\*
  - Low-voltage supply check
  - Criterion voltage : Can be selected as  $2.20 \pm 0.20$  V or  $2.80 \pm 0.30$  V
- Power supply backup\*
  - Backup circuit (voltage multiplier) enables operation at 1.45 V minimum

- Timers and counter
  - 8-bit timer × 4
    - Selectable as auto-reload mode/capture mode/clock frequency measurement mode
  - Watchdog timer × 1
  - 15-bit time base counter × 1
    - 1, 2, 4, 8, 16, 32, 64, and 128 Hz signals can be read
- Serial port
  - Mode : UART mode, synchronous mode
  - UART communication speed : 1200 bps, 2400 bps, 4800 bps, 9600 bps
  - Clock frequency in synchronous mode : 32.768 kHz (internal clock mode), external clock frequency
  - Data length : 5 to 8 bits
- Interrupt sources
  - External interrupt : 3
  - Internal interrupt : 15 (watchdog timer interrupt is a nonmaskable interrupt)
- Operating voltage\*
  - When backup used :  $V_{DD} = 1.45$  to  $2.7$  V
  - When backup not used :  $V_{DD} = 2.7$  to  $5.5$  V
- Package\*:
  - 80-pin plastic QFP (QFP80-P-1420-0.80-BK) : (Product name: MSM63P238-xxxGS-BK)  
xxx indicates a code number.

**BLOCK DIAGRAM**

An asterisk (\*) indicates the port secondary function.   and   indicate that the power is supplied from  $V_{DDI}$  to the circuits corresponding to the signal names inside  , and from  $V_{DDR}$  to the circuits corresponding to signal names inside  . ( $V_{DDI}$  and  $V_{DDR}$ : power supply for interface)

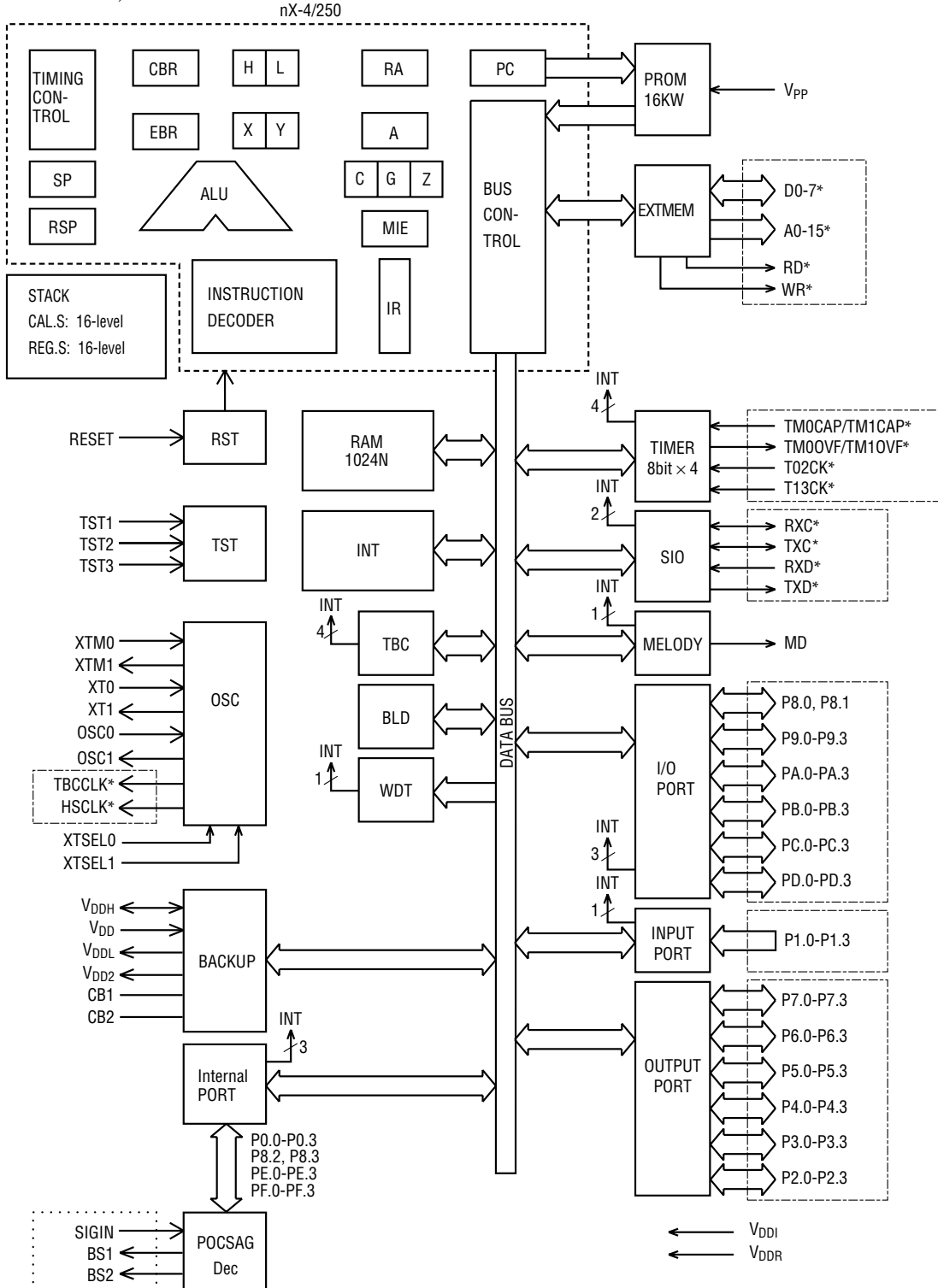

### PIN CONFIGURATION (TOP VIEW)

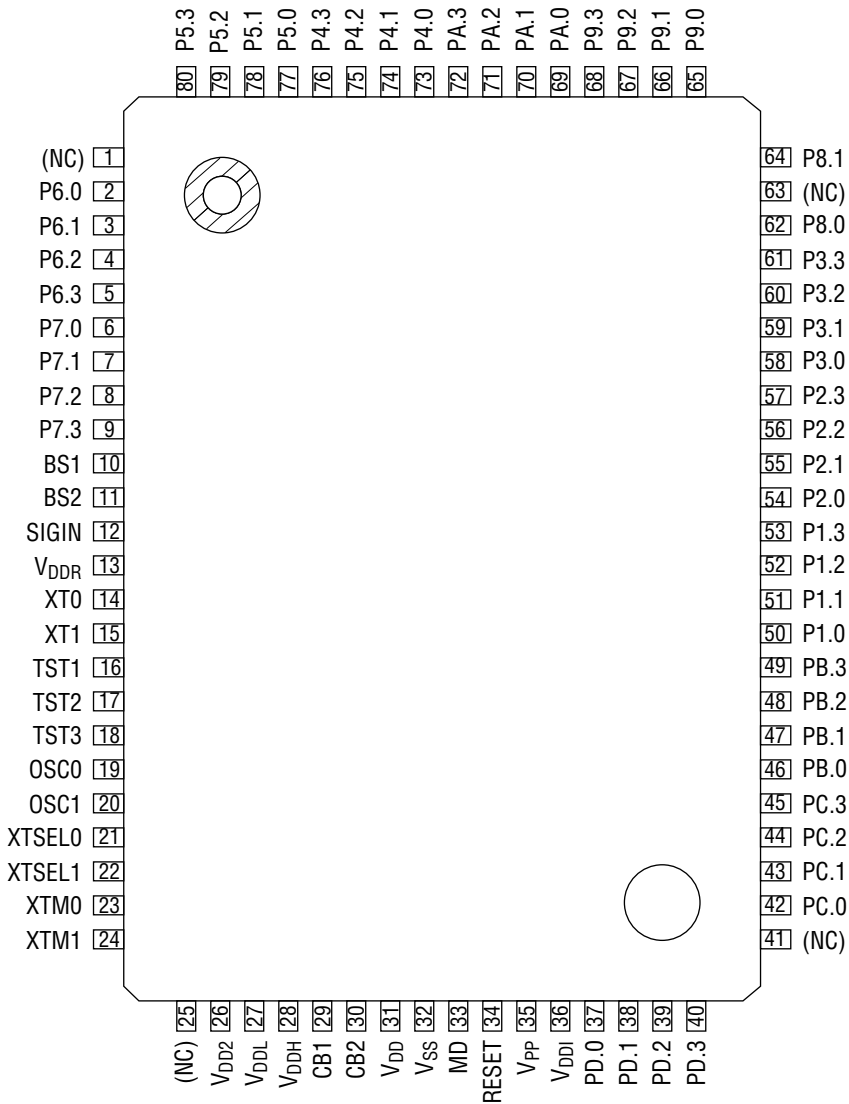

### 80-Pin Plastic QFP

Note: Pins marked as (NC) are no-connection pins which are left open.

**PIN DESCRIPTIONS**

The basic functions of each pin of the MSM63P238 are described in Table 1.

A symbol with a slash (/) denotes a pin that has a secondary function.

Refer to Table 2 for secondary functions.

For type, "—" denotes a power supply pin, "I" an input pin, "O" an output pin, and "I/O" an input-output pin.

**Table 1 Pin Descriptions (Basic Functions)**

Function	Symbol	Pin	Type	Description
Power Supply	V <sub>PP</sub>	35	—	Power supply (+12.5 V) for PROM writing
	V <sub>DD</sub>	31	—	Positive power supply
	V <sub>SS</sub>	32	—	Negative power supply
	V <sub>DDR</sub>	13	—	Interface power supply for SIGIN, BS1, BS2
	V <sub>DDI</sub>	36	—	Positive power supply pin for external interface (power supply for input, output, and I/O ports)
	V <sub>DDL</sub>	27	—	Positive power supply pin for internal logic (internally generated). A capacitor (0.1 μF) should be connected between this pin and V <sub>SS</sub> .
	V <sub>DD2</sub>	26	—	Positive power supply pin for low-speed clock (internally generated)
	V <sub>DDH</sub>	28	—	Voltage multiplier pin for power supply backup (internally generated). A capacitor (1.0 μF) should be connected between this pin and V <sub>SS</sub> .
	CB1	29	—	Pins to connect a capacitor for voltage multiplier.
	CB2	30	—	A capacitor (1.0 μF) should be connected between CB1 and CB2.
Oscillation	XT0	14	I	Clock oscillation pins for POCSAG decoder. A 32.768 kHz, 38.4 kHz, or 76.8 kHz crystal and capacitor (C <sub>G</sub> ) should be connected to these pins.
	XT1	15	O	
	XTM0	23	I	Low-speed clock oscillation pins for CPU.
	XTM1	24	O	A 32.768 kHz crystal and capacitor (C <sub>GM</sub> ) should be connected to these pins.
	OSC0	19	I	High-speed clock oscillation pins.
	OSC1	20	O	A ceramic resonator and capacitors (C <sub>L0</sub> , C <sub>L1</sub> ) or external oscillation resistor (R <sub>OS</sub> ) should be connected to these pins.
	XTSEL0	21	I	Low-speed CPU clock select pins. These pins are used to select a low-speed CPU clock.
	XTSEL1	22		Because these are high impedance inputs, be sure to tie these pins to V <sub>DD</sub> or V <sub>SS</sub> .
Test	TST1	16	I	Input pins for testing.
	TST2	17		Pull-down resistors are internally connected to these pins.
	TST3	18		The user cannot use these pins.
Reset	RESET	34	I	Reset input pin. Setting this pin to "H" level puts this device into a reset state. Then, setting this pin to "L" level starts executing an instruction from address 0000H. A pull-down resistor is internally connected to this pin.

**Table 1 Pin Descriptions (Basic Functions) (continued)**

Function	Symbol	Pin	Type	Description
Melody	MD	33	0	Melody output pin (normal phase)
POCSAG Decoder	BS1	10	0	Battery saving outputs. Signals to control intermittent operations of RF receiver.
	BS2	11		
	SIGIN	12	1	Receive data input pin. Input pin for receive data from RF receiver.
Port	P1.0/INT5	50	1	4-bit input port. Pull-up resistor input, pull-down resistor input, or high-impedance input is selectable for each bit.
	P1.1/INT5	51		
	P1.2/INT5	52		
	P1.3/INT5	53		
	P2.0	54	0	4-bit output ports. P-channel open drain output, N-channel open drain output, CMOS output, or high-impedance output is selectable for each bit.
	P2.1	55		
	P2.2	56		
	P2.3	57		
	P3.0	58	0	
	P3.1	59		
	P3.2	60		
	P3.3	61		
	P4.0/A0	73	0	
	P4.1/A1	74		
	P4.2/A2	75		
	P4.3/A3	76		
	P5.0/A4	77	0	
	P5.1/A5	78		
	P5.2/A6	79		
	P5.3/A7	80		
	P6.0/A8	2	0	
	P6.1/A9	3		
	P6.2/A10	4		
	P6.3/A11	5		
	P7.0/A12	6	0	
	P7.1/A13	7		
	P7.2/A14	8		
	P7.3/A15	9		

**Table 1 Pin Descriptions (Basic Functions) (continued)**

Function	Symbol	Pin	Type	Description
Port	P8.0/ $\overline{RD}$	62	I/O	2-bit input-output port and 4-bit input-output ports. In input mode, pull-up resistor input, pull-down resistor input, or high-impedance input is selectable for each bit. In output mode, P-channel open drain output, N-channel open drain output, CMOS output, or high-impedance output is selectable for each bit.
	P8.1/ $\overline{WR}$	64		
	P9.0/D0	65	I/O	
	P9.1/D1	66		
	P9.2/D2	67		
	P9.3/D3	68		
	PA.0/D4	69	I/O	
	PA.1/D5	70		
	PA.2/D6	71		
	PA.3/D7	72		
	PB.0/INT0/ TM0CAP/ TM0OVF	46	I/O	
	PB.1/INT0/ TM1CAP/ TM1OVF	47		
	PB.2/INT0/ T02CK	48		
	PB.3/INT0/ T13CK	49		
	PC.0/INT1/ RXD	42	I/O	
	PC.1/INT1/ TXC	43		
	PC.2/INT1/ RXC	44		
	PC.3/INT1/ TXD	45		
	PD.0	37	I/O	
	PD.1	38		
PD.2	39			
PD.3	40			



Table 2 shows the secondary functions of each pin of the MSM63P238.

**Table 2 Pin Descriptions (Secondary Functions)**

Function	Symbol	Pin	Type	Description	
External Interrupt	PB.0/INT0	46	I	External 0 interrupt input pins. The change of input signal level causes an interrupt to occur. The Port B Interrupt Enable register (PBIE) enables or disables an interrupt for each bit.	
	PB.1/INT0	47			
	PB.2/INT0	48			
	PB.3/INT0	49			
	PC.0/INT1	42	I	External 1 interrupt input pins. The change of input signal level causes an interrupt to occur. The Port C Interrupt Enable register (PCIE) enables or disables an interrupt for each bit.	
	PC.1/INT1	43			
	PC.2/INT1	44			
	PC.3/INT1	45			
	P1.0/INT5	P1.0/INT5	50	I	External 5 interrupt input pins. The change of input signal level causes an interrupt to occur. The Port 1 Interrupt Enable register (P1IE) enables or disables an interrupt for each bit.
		P1.1/INT5	51		
		P1.2/INT5	52		
		P1.3/INT5	53		
Capture	PB.0/TM0CAP	46	I	Timer 0 capture trigger input pin.	
	PB.1/TM1CAP	47	I	Timer 1 capture trigger input pin.	

**Table 2 Pin Descriptions (Secondary Functions) (continued)**

Function	Symbol	Pin	Type	Description
Timer	PB.0/TM0OVF	46	0	Timer 0 overflow flag output pin.
	PB.1/TM1OVF	47	0	Timer 1 overflow flag output pin.
	PB.2/T02CK	48	I	External clock input pin for timer 0 and timer 2.
	PB.3/T13CK	49	I	External clock input pin for timer 1 and timer 3.
Oscillation Output	PD.2/TBCCLK	39	0	Low-speed oscillation clock output pin
	PD.3/HSCLK	40	0	High-speed oscillation clock output pin
Serial Port	PC.0/RXD	42	I	Serial port receive data input pin
	PC.1/TXC	43	I/O	Sync serial port clock input-output pin. Transmit clock output when this device is used as a master processor. Transmit clock input when this device is used as a slave processor.
	PC.2/RXC	44	I/O	Sync serial port clock input-output pin. Receive clock output when this device is used as a master processor. Receive clock input when this device is used as a slave processor.
	PC.3/TXD	45	0	Serial port transmit data output pin.

**Table 2 Pin Descriptions (Secondary Functions) (continued)**

Function	Symbol	Pin	Type	Description
External Memory	P4.0/A0	73	0	Address output bus for external memory
	P4.1/A1	74		
	P4.2/A2	75		
	P4.3/A3	76		
	P5.0/A4	77		
	P5.1/A5	78		
	P5.2/A6	79		
	P5.3/A7	80		
	P6.0/A8	2		
	P6.1/A9	3		
	P6.2/A10	4		
	P6.3/A11	5		
	P7.0/A12	6		
	P7.1/A13	7		
	P7.2/A14	8		
P7.3/A15	9			
	P9.0/D0	65	I/O	Data bus for external memory
	P9.1/D1	66		
	P9.2/D2	67		
	P9.3/D3	68		
	PA.0/D4	69		
	PA.1/D5	70		
	PA.2/D6	71		
	PA.3/D7	72		
	P8.0/ $\overline{RD}$	62	0	Read signal output pin for external memory (negative logic)
	P8.1/ $\overline{WR}$	64	0	Write signal output pin for external memory (negative logic)

**ABSOLUTE MAXIMUM RATINGS**(V<sub>SS</sub> = 0 V)

Parameter	Symbol	Condition	Rating	Unit
Power Supply Voltage 1	V <sub>DD</sub>	Backup used, Ta = 25°C	-0.3 to +3.0	V
		Backup not used, Ta = 25°C	-0.3 to +6.0	
Power Supply Voltage 2	V <sub>DDI</sub>	Ta = 25°C	-0.3 to +6.0	V
Power Supply Voltage 3	V <sub>DDR</sub>	Ta = 25°C	-0.3 to +6.0	V
Power Supply Voltage 4	V <sub>DDH</sub>	Ta = 25°C	-0.3 to +6.0	V
Power Supply Voltage 5	V <sub>DDL</sub>	Ta = 25°C	-0.3 to +6.0	V
Input Voltage 1	V <sub>IN1</sub>	V <sub>DD</sub> Input, Ta = 25°C	-0.3 to V <sub>DD</sub> + 0.3	V
Input Voltage 2	V <sub>IN2</sub>	V <sub>DDI</sub> Input, Ta = 25°C	-0.3 to V <sub>DDI</sub> + 0.3	V
Input Voltage 3	V <sub>IN3</sub>	V <sub>DDR</sub> Input, Ta = 25°C	-0.3 to V <sub>DDR</sub> + 0.3	V
Output Voltage 1	V <sub>OUT1</sub>	V <sub>DD</sub> output, Ta = 25°C	-0.3 to V <sub>DD</sub> + 0.3	V
Output Voltage 2	V <sub>OUT2</sub>	V <sub>DDI</sub> output, Ta = 25°C	-0.3 to V <sub>DDI</sub> + 0.3	V
Output Voltage 3	V <sub>OUT3</sub>	V <sub>DDR</sub> output, Ta = 25°C	-0.3 to V <sub>DDR</sub> + 0.3	V
Output Voltage 4	V <sub>OUT4</sub>	V <sub>DDH</sub> output, Ta = 25°C	-0.3 to V <sub>DDH</sub> + 0.3	V
Storage Temperature	T <sub>STG</sub>	—	-55 to +150	°C

**RECOMMENDED OPERATING CONDITIONS**

- When backup is used

(V<sub>SS</sub> = 0 V)

Parameter	Symbol	Condition	Range	Unit
Operating Temperature	T <sub>op</sub>	—	0 to +65	°C
Operating Voltage	V <sub>DD</sub>	—	1.45 to 2.7	V
	V <sub>DDI</sub>	—	1.45 to 5.5	V
	V <sub>DDR</sub>	—	1.45 to 5.5	V
Crystal Oscillation Frequency	f <sub>X<sub>T</sub></sub>	—	30 to 80	kHz
	f <sub>X<sub>TM</sub></sub>	—	30 to 35	kHz
Ceramic Oscillation Frequency	f <sub>CM</sub>	V <sub>DD</sub> = 1.45 to 2.7 V	200k to 1M	Hz
External RC Oscillator Resistance	R <sub>OS</sub>	V <sub>DD</sub> = 1.45 to 2.7 V	50 to 300	kΩ

- When backup is not used

(V<sub>SS</sub> = 0 V)

Parameter	Symbol	Condition	Range	Unit
Operating Temperature	T <sub>op</sub>	—	0 to +65	°C
Operating Voltage	V <sub>DD</sub>	—	2.7 to 5.5	V
	V <sub>DDI</sub>	—	1.8 to 5.5	V
	V <sub>DDR</sub>	—	1.8 to 5.5	V
Crystal Oscillation Frequency	f <sub>X<sub>T</sub></sub>	—	30 to 80	kHz
	f <sub>X<sub>TM</sub></sub>	—	30 to 35	kHz
Ceramic Oscillation Frequency	f <sub>CM</sub>	V <sub>DD</sub> = 2.7 to 5.5 V	300k to 1M	Hz
		V <sub>DD</sub> = 2.9 to 5.5 V	200k to 2M	
External RC Oscillator Resistance	R <sub>OS</sub>	V <sub>DD</sub> = 2.7 to 5.5 V	50 to 300	kΩ
		V <sub>DD</sub> = 2.9 to 5.5 V	30 to 300	

## ELECTRICAL CHARACTERISTICS

### DC Characteristics

( $V_{DD} = V_{DD1} = V_{DDR} = 1.45$  to  $5.5$  V,  $V_{DDH} = 2.7$  to  $5.5$  V,  $V_{SS} = 0$  V,  $T_a = 0$  to  $+65^\circ\text{C}$  unless otherwise specified)

Parameter	Symbol	Condition	Min.	Typ.	Max.	Unit	Measuring Circuit
V <sub>DDL</sub> Voltage	V <sub>DDL</sub>	High speed clock stop	1.2	1.6	2.0	V	1
		High speed clock oscillation	1.45	—	5.5	V	
V <sub>DD2</sub> Voltage	V <sub>DD2</sub>	—	1.2	1.6	2.0	V	
Crystal Oscillation Start Voltage	V <sub>STA</sub>	Oscillation start time: within 5 seconds	1.45	—	—	V	
Crystal Oscillation Hold Voltage	V <sub>HOLD</sub>	—	1.45	—	—	V	
Crystal Oscillation Stop Detect Time	T <sub>STOP</sub>	—	0.1	—	5.0	ms	
External Crystal Oscillator Capacitance	C <sub>G</sub> , C <sub>GM</sub>	—	12	—	30	pF	
Internal Crystal Oscillator Capacitance	C <sub>D</sub> , C <sub>DM</sub>	—	12	15	20	pF	
Internal RC Oscillator Capacitance	C <sub>OS</sub>	—	8	12	16	pF	
POR Voltage	V <sub>POR1</sub>	V <sub>DD</sub> = 1.5 V	0.0	—	0.4	V	
		V <sub>DD</sub> = 3.0 V	0.0	—	0.7	V	
Non-POR Voltage	V <sub>POR2</sub>	V <sub>DD</sub> = 1.5 V	1.45	—	1.5	V	
		V <sub>DD</sub> = 3.0 V	2.7	—	3.0	V	

- Notes:
- "T<sub>STOP</sub>" indicates that if the crystal oscillator stops over the value of T<sub>STOP</sub>, the system reset occurs.
  - "POR" denotes Power On Reset.
  - "V<sub>POR1</sub>" indicates that POR occurs when V<sub>DD</sub> falls from V<sub>DD</sub> to V<sub>POR1</sub> and again rises up to V<sub>DD</sub>.
  - "V<sub>POR2</sub>" indicates that POR does not occur when V<sub>DD</sub> falls from V<sub>DD</sub> to V<sub>POR2</sub> and again rises up to V<sub>DD</sub>.

**DC Characteristics (continued)**

- When backup is used

( $V_{DD} = V_{DD1} = 1.5\text{ V}$ ,  $V_{DDH} = 3.0\text{ V}$ ,  $V_{SS} = 0\text{ V}$ ,  $T_a = 0\text{ to }+65^\circ\text{C}$  unless otherwise specified)

Parameter	Symbol	Condition	Min.	Typ.	Max.	Unit	Measuring Circuit
Supply Current 1	$I_{DD1}$	CPU in HALT mode. (High-speed clock oscillation stop) Decoder in HALT mode. (Decoder oscillation stop)	—	7.0	35	$\mu\text{A}$	1
Supply Current 2	$I_{DD2}$	CPU in HALT mode. (High-speed clock oscillation stop) Decoder in carrier on state. (76.8 kHz operation)	—	17	40	$\mu\text{A}$	
Supply Current 3	$I_{DD3}$	CPU in HALT mode. (High-speed clock oscillation stop) Decoder in data receiving state. (76.8 kHz operation)	—	85	200	$\mu\text{A}$	
Supply Current 4	$I_{DD4}$	CPU in operation at 32 kHz. (High-speed clock oscillation stop) Decoder in HALT mode. (Decoder oscillation stop)	—	230	400	$\mu\text{A}$	
Supply Current 5	$I_{DD5}$	CPU in operation at high speed. (RC oscillation, $R_{OS} = 51\text{ k}\Omega$ ) Decoder in HALT mode. (Decoder oscillation stop)	—	1.5	2.0	$\text{mA}$	
Supply Current 6	$I_{DD6}$	CPU in operation at high speed. (Ceramic oscillation, 1 MHz) Decoder in HALT mode. (Decoder oscillaiton stop)	—	2.0	3.0	$\text{mA}$	

**DC Characteristics (continued)**

- When backup is not used

( $V_{DD} = V_{DD1} = V_{DDH} = 3.0\text{ V}$ ,  $V_{SS} = 0\text{ V}$ ,  $T_a = 0\text{ to }+65^\circ\text{C}$  unless otherwise specified)

Parameter	Symbol	Condition	Min.	Typ.	Max.	Unit	Measuring Circuit
Supply Current 1	$I_{DD1}$	CPU in HALT mode. (High-speed clock oscillation stop) Decoder in HALT mode. (Decoder oscillation stop)	—	3.0	20	$\mu\text{A}$	1
Supply Current 2	$I_{DD2}$	CPU in HALT mode. (High-speed clock oscillation stop) Decoder in carrier on state. (76.8 kHz operation)	—	8.0	20	$\mu\text{A}$	
Supply Current 3	$I_{DD3}$	CPU in HALT mode. (High-speed clock oscillation stop) Decoder in data receiving state. (76.8 kHz operation)	—	42	100	$\mu\text{A}$	
Supply Current 4	$I_{DD4}$	CPU in operation at 32 kHz. (High-speed clock oscillation stop) Decoder in HALT mode. (Decoder oscillation stop)	—	120	200	$\mu\text{A}$	
Supply Current 5	$I_{DD5}$	CPU in operation at high speed. (RC oscillation, $R_{OS} = 51\text{ k}\Omega$ ) Decoder in HALT mode. (Decoder oscillation stop)	—	1.5	2.0	$\text{mA}$	
Supply Current 6	$I_{DD6}$	CPU in operation at high speed. (Ceramic oscillation, 2 MHz) Decoder in HALT mode. (Decoder oscillation stop)	—	3.5	5.0	$\text{mA}$	



DC Characteristics (continued)

( $V_{DD} = V_{DD1} = V_{DDH} = V_{DDR} = 3.0\text{ V}$ ,  $V_{SS} = 0\text{ V}$ ,  $T_a = 0\text{ to }+65^\circ\text{C}$  unless otherwise specified)

Parameter	Symbol	Condition	Min.	Typ.	Max.	Unit	Measuring Circuit	
Output Current 1 (P2.0 to P2.3) (P3.0 to P3.3) (P4.0 to P4.3) ⋮ (PC.0 to PC.3) (PD.0 to PD.3)	$I_{OH1}$	$V_{OH1} = V_{DD1} - 0.5\text{ V}$	$V_{DD1} = 1.5\text{ V}$	-2.0	-1.2	-0.4	mA	2
			$V_{DD1} = 3.0\text{ V}$	-5.0	-3.0	-1.0	mA	
			$V_{DD1} = 5.0\text{ V}$	-8.0	-4.0	-2.0	mA	
	$I_{OL1}$	$V_{OL1} = 0.5\text{ V}$	$V_{DD1} = 1.5\text{ V}$	0.4	1.4	2.0	mA	
			$V_{DD1} = 3.0\text{ V}$	1.0	3.0	5.0	mA	
			$V_{DD1} = 5.0\text{ V}$	2.0	4.0	8.0	mA	
Output Current 2 (MD)	$I_{OH2}$	$V_{OH2} = V_{DD} - 0.7\text{ V}$	$V_{DD} = 1.5\text{ V}$	-2.5	-1.3	-0.5	mA	
			$V_{DD} = 3.0\text{ V}$	-6.0	-4.0	-2.0	mA	
			$V_{DD} = V_{DDH} = 5.0\text{ V}$	-9.0	-5.5	-4.0	mA	
	$I_{OL2}$	$V_{OL2} = 0.7\text{ V}$	$V_{DD} = 1.5\text{ V}$	0.5	1.3	2.5	mA	
			$V_{DD} = 3.0\text{ V}$	2.0	4.0	6.0	mA	
			$V_{DD} = V_{DDH} = 5.0\text{ V}$	4.0	5.5	9.0	mA	
Output Current 3 (BS1, BS2)	$I_{OH3}$	$V_{OH3} = V_{DDR} - 0.5\text{ V}$	$V_{DDR} = 1.5\text{ V}$	-6.0	-3.6	-1.2	mA	
			$V_{DDR} = 3.0\text{ V}$	-15.0	-9.0	-3.0	mA	
			$V_{DDR} = 5.0\text{ V}$	-24.0	-12.0	-6.0	mA	
	$I_{OL3}$	$V_{OL3} = 0.5\text{ V}$	$V_{DDR} = 1.5\text{ V}$	1.2	3.6	6.0	mA	
			$V_{DDR} = 3.0\text{ V}$	3.0	9.0	15.0	mA	
			$V_{DDR} = 5.0\text{ V}$	6.0	12.0	24.0	mA	
Output Current 4 (OSC1)	$I_{OH4R}$	$V_{OH4R} = V_{DDH} - 0.5\text{ V}$ (RC oscillation)	$V_{DD} = V_{DDH} = 3.0\text{ V}$	-2.5	-1.5	-0.75	mA	
			$V_{DD} = V_{DDH} = 5.0\text{ V}$	-3.0	-2.0	-1.0	mA	
	$I_{OL4R}$	$V_{OL4R} = 0.5\text{ V}$ (RC oscillation)	$V_{DD} = V_{DDH} = 3.0\text{ V}$	0.75	1.5	2.5	mA	
			$V_{DD} = V_{DDH} = 5.0\text{ V}$	1.0	2.0	3.5	mA	
	$I_{OH4C}$	$V_{OH4C} = V_{DDH} - 0.5\text{ V}$ (ceramic oscillation)	$V_{DD} = V_{DDH} = 3.0\text{ V}$	-240	-120	-60	$\mu\text{A}$	
			$V_{DD} = V_{DDH} = 5.0\text{ V}$	-400	-200	-100	$\mu\text{A}$	
	$I_{OL4C}$	$V_{OL4C} = 0.5\text{ V}$ (ceramic oscillation)	$V_{DD} = V_{DDH} = 3.0\text{ V}$	60	120	250	$\mu\text{A}$	
			$V_{DD} = V_{DDH} = 5.0\text{ V}$	100	200	400	$\mu\text{A}$	
Output Leakage (P2.0 to P2.3) (P3.0 to P3.3) (P4.0 to P4.3) ⋮ (PD.0 to PD.3)	$I_{OOH}$	$V_{OH} = V_{DD1}$	—	—	1.0	$\mu\text{A}$		
	$I_{OOL}$	$V_{OL} = V_{SS}$	-1.0	—	—	$\mu\text{A}$		

DC Characteristics (continued)

( $V_{DD} = V_{DD1} = V_{DDH} = V_{DDR} = 3.0\text{ V}$ ,  $V_{SS} = 0\text{ V}$ ,  $T_a = 0\text{ to }+65^\circ\text{C}$  unless otherwise specified)

Parameter	Symbol	Condition	Min.	Typ.	Max.	Unit	Measuring Circuit	
Input Current 1 (P1.0 to P1.3) (P8.0, P8.1) (P9.0 to P9.3) ⋮ (PD.0 to PD.3)	$I_{IH1}$	$V_{IH1} = V_{DD1}$ (when pulled down)	$V_{DD1} = 1.5\text{ V}$	2	10	30	$\mu\text{A}$	
			$V_{DD1} = 3.0\text{ V}$	30	90	180	$\mu\text{A}$	
			$V_{DD1} = 5.0\text{ V}$	70	250	600	$\mu\text{A}$	
	$I_{IL1}$	$V_{IL1} = V_{SS}$ (when pulled up)	$V_{DD1} = 1.5\text{ V}$	-30	-10	-2	$\mu\text{A}$	
			$V_{DD1} = 3.0\text{ V}$	-180	-90	-30	$\mu\text{A}$	
			$V_{DD1} = 5.0\text{ V}$	-600	-250	-70	$\mu\text{A}$	
$I_{IH1Z}$	$V_{IH1} = V_{DD1}$ (in a high impedance state)	0.0	—	1.0	$\mu\text{A}$			
$I_{IL1Z}$	$V_{IL1} = V_{SS}$ (in a high impedance state)	-1.0	—	0.0	$\mu\text{A}$			
Input Current 2 (SIGIN)	$I_{IH2Z}$	$V_{IH2} = V_{DDR}$	0.0	—	1.0	$\mu\text{A}$		
	$I_{IL2Z}$	$V_{IL2} = V_{SS}$	-1.0	—	0.0	$\mu\text{A}$		
Input Current 3 (OSCO)	$I_{IL3}$	$V_{IL3} = V_{SS}$ (when pulled up)	$V_{DD} = V_{DDH} = 3.0\text{ V}$	-200	-110	-30	$\mu\text{A}$	
			$V_{DD} = V_{DDH} = 5.0\text{ V}$	-600	-350	-150	$\mu\text{A}$	
	$I_{IH3R}$	$V_{IH3} = V_{DDH}$ (RC oscillation)	0.0	—	1.0	$\mu\text{A}$		
	$I_{IL3R}$	$V_{IL3} = V_{SS}$ (RC oscillation)	-1.0	—	0.0	$\mu\text{A}$		
	$I_{IH3C}$	$V_{IH3} = V_{DDH}$ (ceramic oscillation)	$V_{DD} = V_{DDH} = 3.0\text{ V}$	0.1	0.5	1.0	$\mu\text{A}$	
			$V_{DD} = V_{DDH} = 5.0\text{ V}$	0.75	1.5	3.0	$\mu\text{A}$	
$I_{IL3C}$	$V_{IL3} = V_{SS}$ (ceramic oscillation)	$V_{DD} = V_{DDH} = 3.0\text{ V}$	-1.0	-0.5	-0.1	$\mu\text{A}$		
		$V_{DD} = V_{DDH} = 5.0\text{ V}$	-3.0	-1.5	-0.75	$\mu\text{A}$		
Input Current 4 (RESET)	$I_{IH4}$	$V_{IH4} = V_{DD}$	$V_{DD} = 1.5\text{ V}$	10	50	80	$\mu\text{A}$	
			$V_{DD} = 3.0\text{ V}$	150	350	600	$\mu\text{A}$	
			$V_{DD} = V_{DDH} = 5.0\text{ V}$	0.5	1.0	2.0	$\text{mA}$	
	$I_{IL4}$	$V_{IL4} = V_{SS}$	-1.0	—	0.0	$\mu\text{A}$		
Input Current 5 (TST1, TST2, TST3)	$I_{IH5}$	$V_{IH5} = V_{DD}$	$V_{DD} = 1.5\text{ V}$	50	150	300	$\mu\text{A}$	
			$V_{DD} = 3.0\text{ V}$	0.5	1.0	1.5	$\text{mA}$	
			$V_{DD} = V_{DDH} = 5.0\text{ V}$	1.25	2.5	4.0	$\text{mA}$	
	$I_{IL5}$	$V_{IL5} = V_{SS}$	-1.0	—	0.0	$\mu\text{A}$		
Input Current 6 (XTSEL0, XTSEL1)	$I_{IH6Z}$	$V_{IH6} = V_{DD}$	0.0	—	1.0	$\mu\text{A}$		
	$I_{IL6Z}$	$V_{IL6} = V_{SS}$	-1.0	—	0.0	$\mu\text{A}$		

3

DC Characteristics (continued)

( $V_{DD} = V_{DDI} = V_{DDH} = V_{DDR} = 3.0\text{ V}$ ,  $V_{SS} = 0\text{ V}$ ,  $T_a = 0\text{ to }+65^\circ\text{C}$  unless otherwise specified)

Parameter	Symbol	Condition	Min.	Typ.	Max.	Unit	Measuring Circuit
Input Voltage 1 (P1.0 to P1.3) (P8.0, P8.1) (P9.0 to P9.3) ⋮ (PD.0 to PD.3)	$V_{IH1}$	$V_{DDI} = 1.5\text{ V}$	1.2	—	1.5	V	4
		$V_{DDI} = 3.0\text{ V}$	2.4	—	3.0	V	
		$V_{DDI} = 5.0\text{ V}$	4.0	—	5.0	V	
	$V_{IL1}$	$V_{DDI} = 1.5\text{ V}$	0.0	—	0.3	V	
		$V_{DDI} = 3.0\text{ V}$	0.0	—	0.6	V	
		$V_{DDI} = 5.0\text{ V}$	0.0	—	1.0	V	
Input Voltage 2 (SIGIN)	$V_{IH2}$	$V_{DDR} = 1.5\text{ V}$	1.2	—	1.5	V	
		$V_{DDR} = 3.0\text{ V}$	2.4	—	3.0	V	
		$V_{DDR} = 5.0\text{ V}$	4.0	—	5.0	V	
	$V_{IL2}$	$V_{DDR} = 1.5\text{ V}$	0.0	—	0.3	V	
		$V_{DDR} = 3.0\text{ V}$	0.0	—	0.6	V	
		$V_{DDR} = 5.0\text{ V}$	0.0	—	1.0	V	
Input Voltage 3 (OSCO)	$V_{IH3}$	$V_{DD} = V_{DDH} = 3.0\text{ V}$	2.4	—	3.0	V	
		$V_{DD} = V_{DDH} = 5.0\text{ V}$	4.0	—	5.0	V	
	$V_{IL3}$	$V_{DD} = V_{DDH} = 3.0\text{ V}$	0.0	—	0.6	V	
		$V_{DD} = V_{DDH} = 5.0\text{ V}$	0.0	—	1.0	V	
Input Voltage 4 (RESET, TST1, TST2, TST3, XTSELO, XTSEL1)	$V_{IH4}$	$V_{DD} = 1.5\text{ V}$	1.35	—	1.5	V	
		$V_{DD} = 3.0\text{ V}$	2.4	—	3.0	V	
		$V_{DD} = V_{DDH} = 5.0\text{ V}$	4.0	—	5.0	V	
	$V_{IL4}$	$V_{DD} = 1.5\text{ V}$	0.0	—	0.15	V	
		$V_{DD} = 3.0\text{ V}$	0.0	—	0.6	V	
		$V_{DD} = V_{DDH} = 5.0\text{ V}$	0.0	—	1.0	V	
Hysteresis Width 1 (P1.0 to P1.3) (P8.0, P8.1) ⋮ (PD.0 to PD.3)	$\Delta V_{T1}$	$V_{DDI} = 1.5\text{ V}$	0.05	0.1	0.3	V	
		$V_{DDI} = 3.0\text{ V}$	0.2	0.5	1.0	V	
		$V_{DDI} = 5.0\text{ V}$	0.25	1.0	1.5	V	
Hysteresis Width 2 (RESET, TST1, TST2, TST3, XTSELO, XTSEL1)	$\Delta V_{T2}$	$V_{DD} = 1.5\text{ V}$	0.05	0.1	0.3	V	
		$V_{DD} = 3.0\text{ V}$	0.2	0.5	1.0	V	
		$V_{DD} = V_{DDH} = 5.0\text{ V}$	0.25	1.0	1.5	V	
Input Pin Capacitance (P1.0 to P1.3) (P8.0, P8.1) (P9.0 to P9.3) ⋮ (PD.0 to PD.3)	$C_{IN}$	—	—	—	5	pF	1

Measuring circuit 1

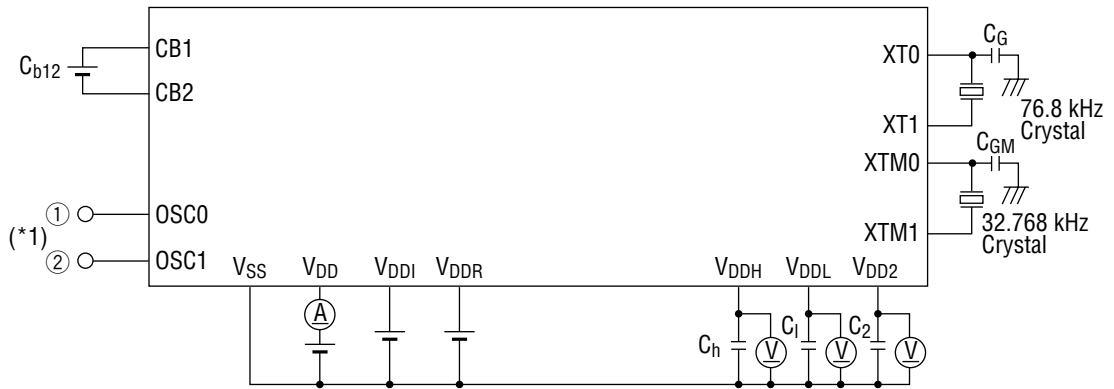

- $C_1, C_2$  : 0.1  $\mu\text{F}$
- $C_h, C_{b12}$  : 1  $\mu\text{F}$
- $C_G, C_{GM}$  : 15 pF
- $C_{L0}$  : 30 pF
- $C_{L1}$  : 30 pF
- Ceramic Resonator : CSA2.00MG (2 MHz)  
(Murata MFG.-make)

\*1 RC Oscillator

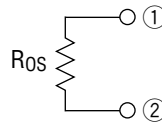

Ceramic Oscillator

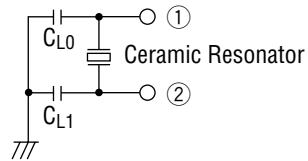

Measuring circuit 2

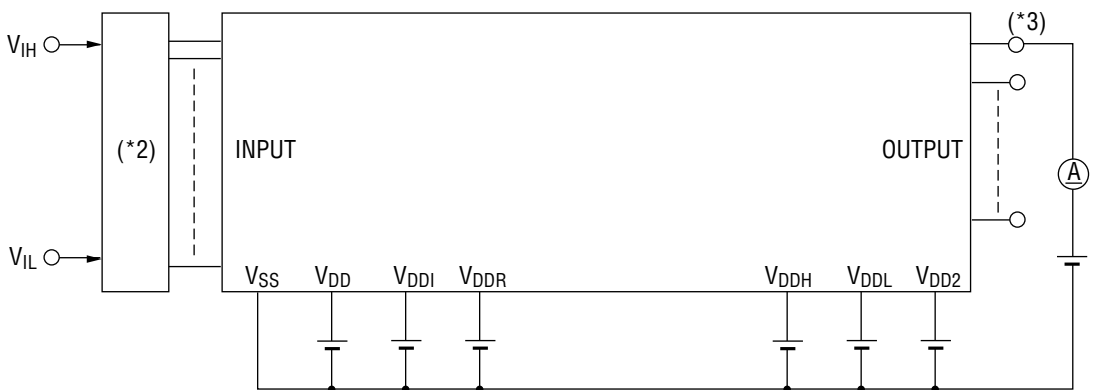

\*2 Input logic circuit to determine the specified measuring conditions.

\*3 Measured at the specified output pins.

Measuring circuit 3

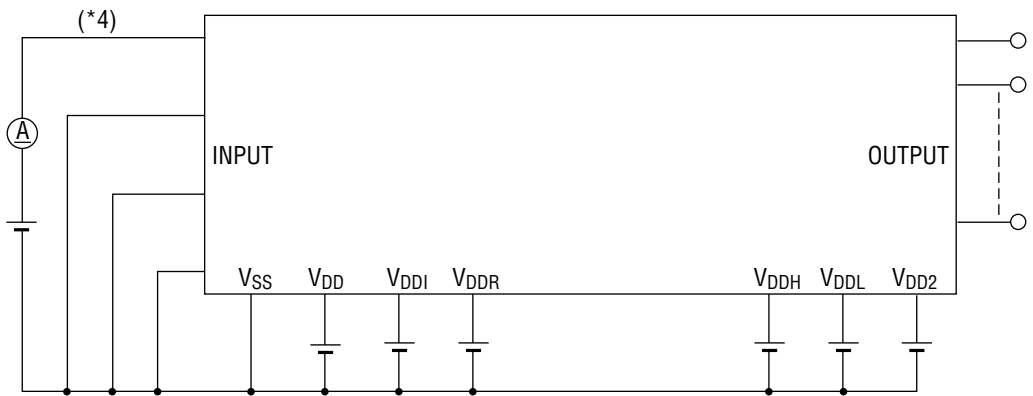

Measuring circuit 4

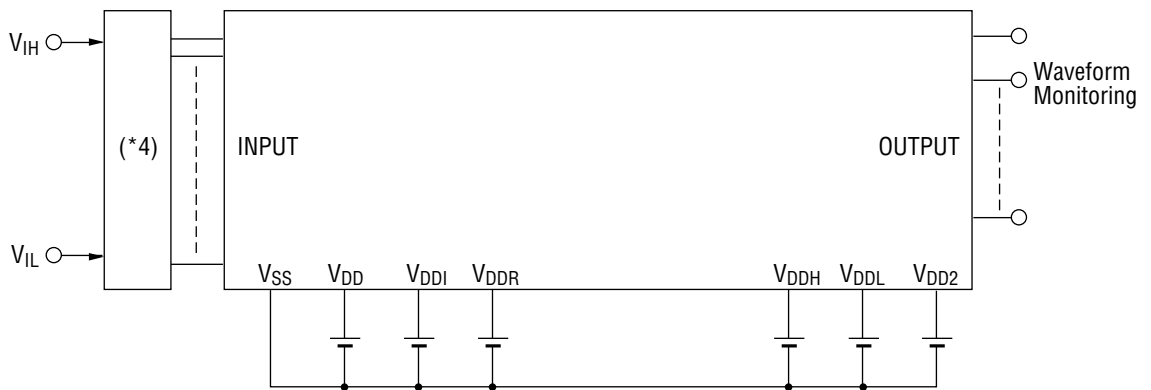

\*4 Measured at the specified input pins.

**AC Characteristics (Serial Interface, Serial Port)**

( $V_{DD} = V_{DDR} = 1.45$  to  $5.5$  V,  $V_{DDH} = 2.7$  to  $5.5$  V,  $V_{SS} = 0$  V,  $V_{DDI} = 5.0$  V,  $T_a = 0$  to  $+65^\circ\text{C}$  unless otherwise specified)

(1) Synchronous Communication

Parameter	Symbol	Condition	Min.	Typ.	Max.	Unit
TXC/RXC Input Fall Time	$t_f$	—	—	—	1.0	$\mu\text{s}$
TXC/RXC Input Rise Time	$t_r$	—	—	—	1.0	$\mu\text{s}$
TXC/RXC Input "L" Level Pulse Width	$t_{cWL}$	—	0.8	—	—	$\mu\text{s}$
TXC/RXC Input "H" Level Pulse Width	$t_{cWH}$	—	0.8	—	—	$\mu\text{s}$
TXC/RXC Input Cycle Time	$t_{cYC}$	—	2.0	—	—	$\mu\text{s}$
TXC/RXC Output Cycle Time	$t_{cYC1(0)}$	CPU in operation state at 32 kHz	—	30.5	—	$\mu\text{s}$
	$t_{cYC2(0)}$	CPU in operation at 2 MHz $V_{DD} = V_{DDH} = 2.9$ V to $5.5$ V	—	0.5	—	$\mu\text{s}$
TXD Output Delay Time	$t_{DDR}$	Output load capacitance 10 pF	—	—	0.4	$\mu\text{s}$
RXD Input Setup Time	$t_{DS}$	—	0.5	—	—	$\mu\text{s}$
RXD Input Hold Time	$t_{DH}$	—	0.8	—	—	$\mu\text{s}$

Synchronous communication timing  
("H" level = 4.0 V, "L" level = 1.0 V)

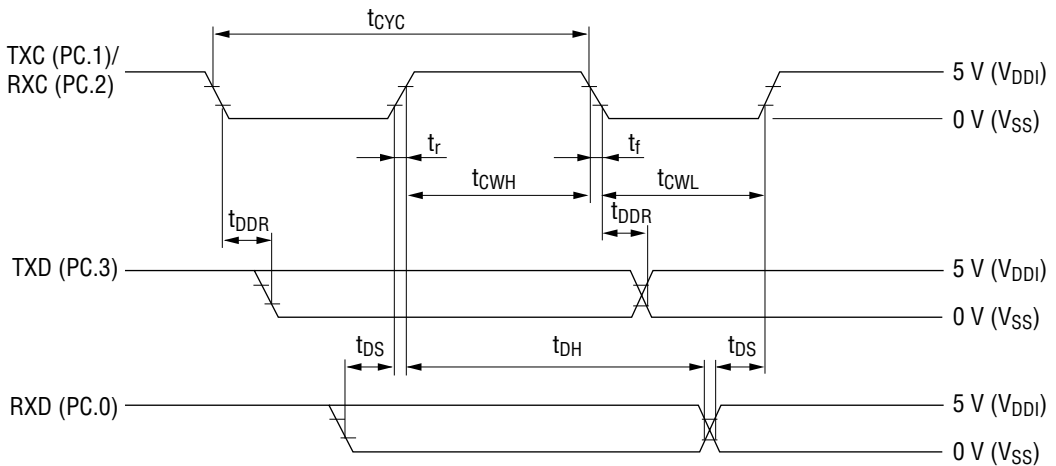

(2) UART Communication

Parameter	Symbol	Condition	Min.	Typ.	Max.	Unit
Transmit Baud Rate	$T_{BRT}$	$T_{BRT} = 1/f_{BRT}$ $T_{CR} = 1/f_{OSC}$	$T_{BRT} - T_{CR}$	$T_{BRT}$	$T_{BRT} + T_{CR}$	s
Receive Baud Rate	$R_{BRT}$	$R_{BRT} = 1/f_{BRT}$	$R_{BRT} \times 0.97$	$R_{BRT}$	$R_{BRT} \times 1.03$	s

$f_{BRT}$ : Baud rates (1200, 2400, 4800, 9600 bps)

UART communication timing

("H" level = 4.0 V, "L" level = 1.0 V)

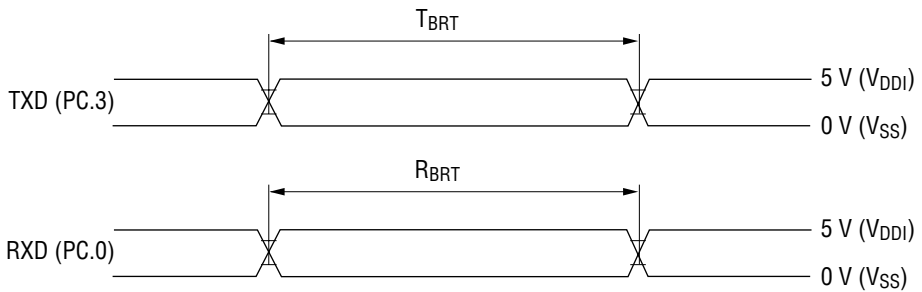

**AC Characteristics (External Memory Interface)**

( $V_{DD} = V_{DDR} = 1.45$  to  $5.5$  V,  $V_{DDH} = 2.7$  to  $5.5$  V,  $V_{SS} = 0$  V,  $V_{DDI} = 5.0$  V,  $T_a = 0$  to  $+65^\circ\text{C}$  unless otherwise specified)

(1) Reading from External Memory

(a) When CPU operates at 32.768 kHz

Parameter	Symbol	Condition	Min.	Typ.	Max.	Unit
Read Cycle Time	$t_{RC}$	—	—	61.0	—	$\mu\text{s}$
$\overline{\text{RD}}$ Output Delay Time	$t_{OE}$	—	—	—	5.0	$\mu\text{s}$
Output Valid Time	$t_{OHA}$	—	—	—	5.0	$\mu\text{s}$
External Memory Output Delay Time	$t_{DO}$	—	—	—	5.0	$\mu\text{s}$

(b) When CPU operates at 2 MHz ( $V_{DDH} = 2.9$  to  $5.5$  V)

Parameter	Symbol	Condition	Min.	Typ.	Max.	Unit
Read Cycle Time	$t_{RC}$	—	1.0	—	—	$\mu\text{s}$
$\overline{\text{RD}}$ Output Delay Time	$t_{OE}$	—	—	—	100	ns
Output Valid Time	$t_{OHA}$	—	—	—	100	ns
External Memory Output Delay Time	$t_{DO}$	—	—	—	150	ns

AC characteristics timing

("H" level = 4.0 V, "L" level = 1.0 V)

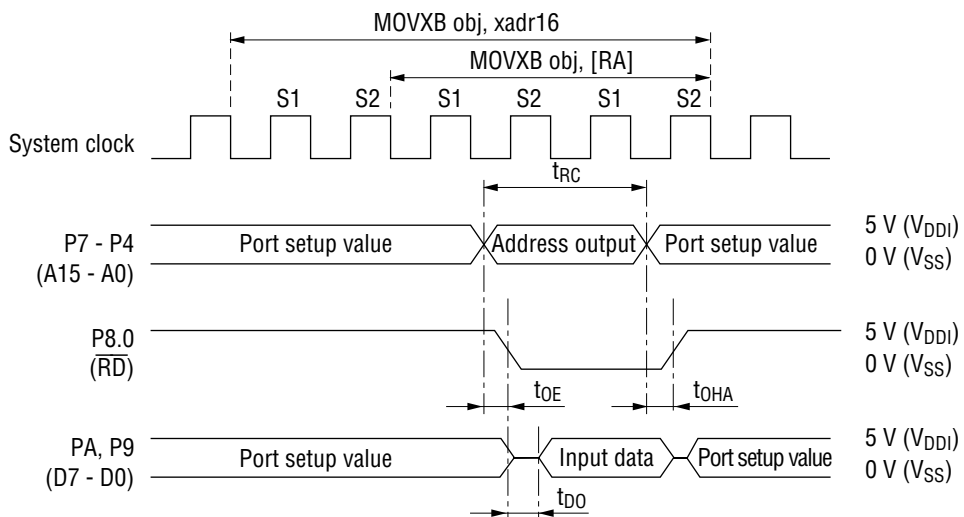



(2) Writing to External Memory

(a) When CPU operates at 32.768 kHz

Parameter	Symbol	Condition	Min.	Typ.	Max.	Unit
Write Cycle Time	$t_{WC}$	—	—	61.0	—	$\mu\text{s}$
Address Setup Time	$t_{AS}$	—	—	30.5	—	$\mu\text{s}$
Write Time	$t_W$	—	—	15.3	—	$\mu\text{s}$
Write Recovery Time	$t_{WR}$	—	—	15.3	—	$\mu\text{s}$
Data Setup Time	$t_{DS}$	—	—	45.8	—	$\mu\text{s}$
Data Hold Time	$t_{DH}$	—	—	15.3	—	$\mu\text{s}$

(b) When CPU operates at 2 MHz ( $V_{DDH} = 2.9$  to 5.5 V)

Parameter	Symbol	Condition	Min.	Typ.	Max.	Unit
Write Cycle Time	$t_{WC}$	—	1.0	—	—	$\mu\text{s}$
Address Setup Time	$t_{AS}$	—	0.4	—	—	$\mu\text{s}$
Write Time	$t_W$	—	0.2	—	—	$\mu\text{s}$
Write Recovery Time	$t_{WR}$	—	0.2	—	—	$\mu\text{s}$
Data Setup Time	$t_{DS}$	—	0.7	—	—	$\mu\text{s}$
Data Hold Time	$t_{DH}$	—	0.2	—	—	$\mu\text{s}$

AC characteristics timing

("H" level = 4.0 V, "L" level = 1.0 V)

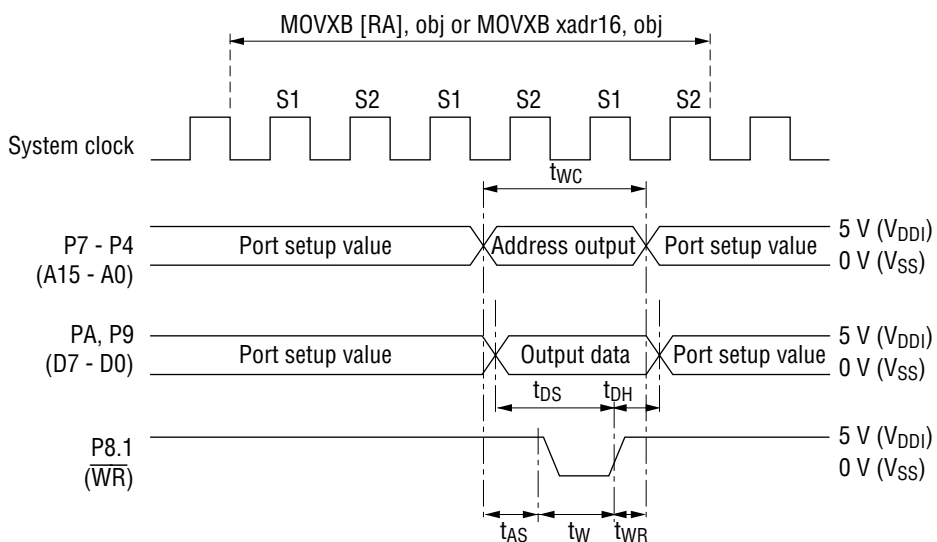

APPLICATION CIRCUITS

- RC oscillation is selected as high-speed oscillation.
- Ports and RF section are powered from external memory power source.
- $C_V$  is an IC power supply bypass capacitor.
- Values of  $C_1$ ,  $C_2$ ,  $C_G$ ,  $C_{GM}$ ,  $C_h$ ,  $C_{b12}$ , and  $C_V$  are for reference only.

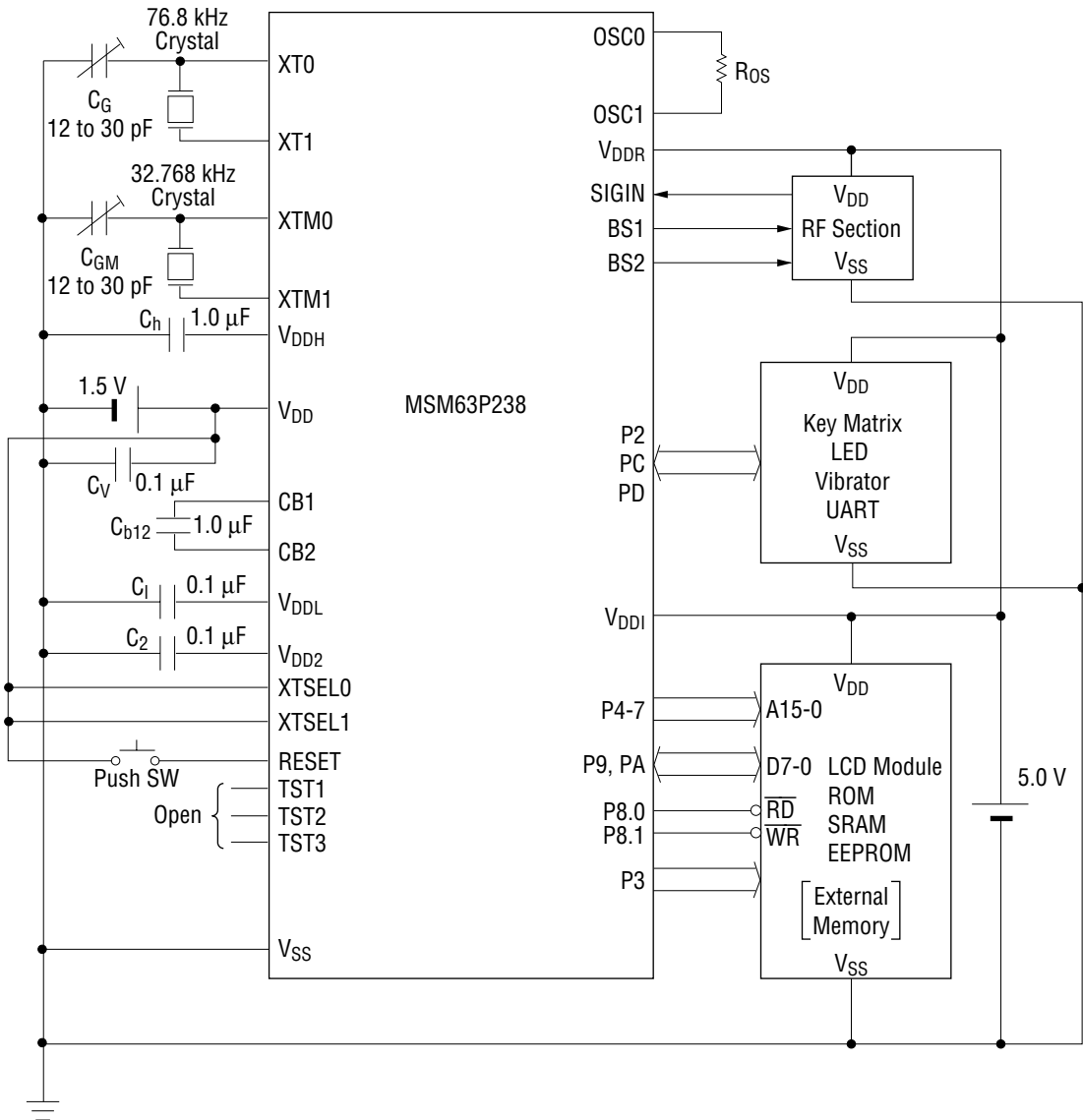

Note:  $V_{DDI}$  is the power supply pin for the input, output, and input-output ports.  $V_{DDR}$  is the interface power supply pin for SIGIN, BS1, and BS2. Be sure to connect the  $V_{DDI}$  and  $V_{DDR}$  pins either to the positive power supply pin ( $V_{DD}$ ) of this device or to the positive power supply pin of the external memory.

Application Circuit Example with Power Supply Backup

APPLICATION CIRCUITS (continued)

- Ceramic oscillation is selected as high-speed oscillation.
- Ports and RF section are powered from external memory power source.
- $C_V$  is an IC power supply bypass capacitor.
- Values of  $C_1$ ,  $C_2$ ,  $C_G$ ,  $C_V$ ,  $C_{L0}$ , and  $C_{L1}$  are for reference only.

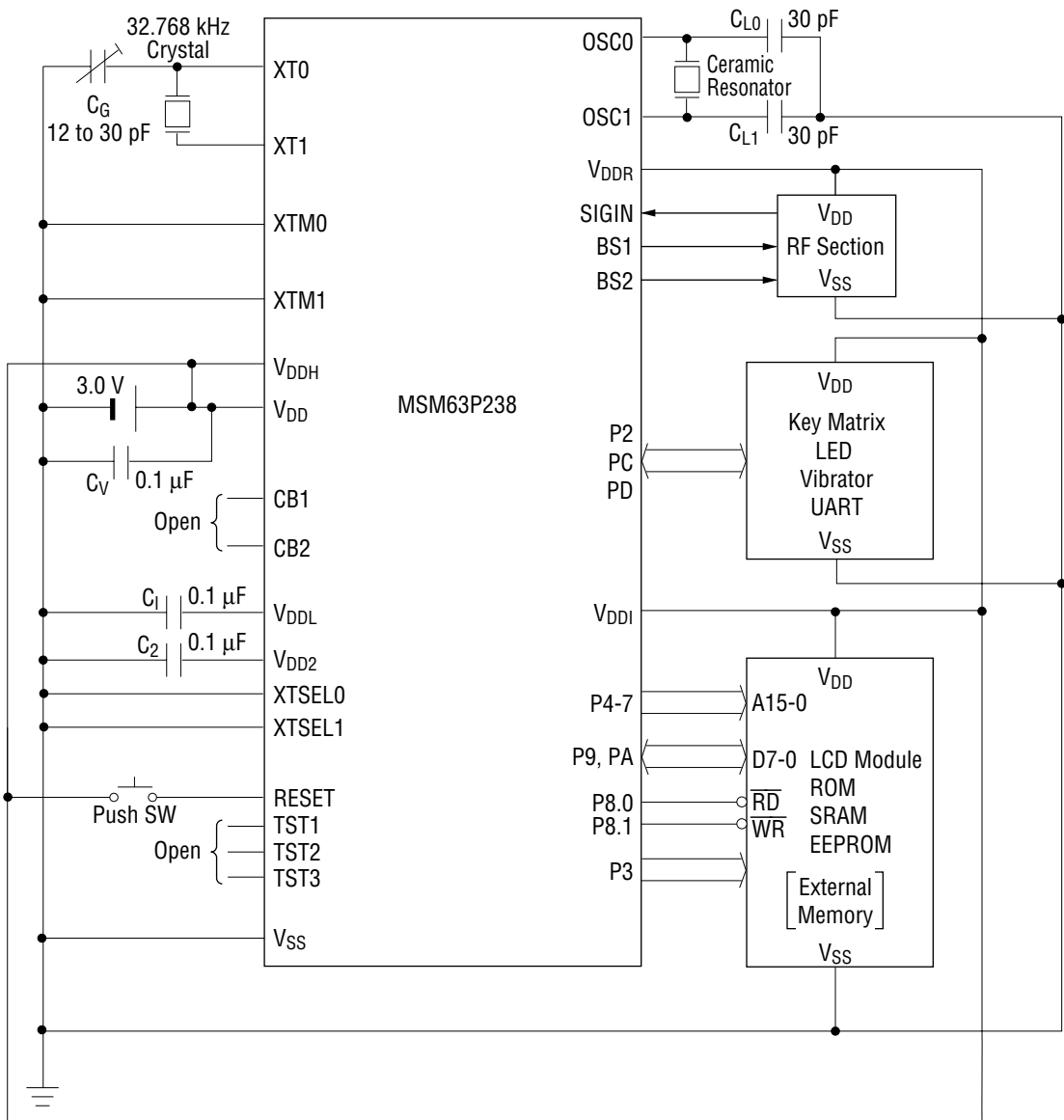

Note: V<sub>DDI</sub> is the power supply pin for the input, output, and input-output ports. V<sub>DDR</sub> is the interface power supply pin for SIGIN, BS1, and BS2. Be sure to connect the V<sub>DDI</sub> and V<sub>DDR</sub> pins either to the positive power supply pin (V<sub>DD</sub>) of this device or to the positive power supply pin of the external memory.

Application Circuit Example with No Power Supply Backup

PACKAGE DIMENSIONS

(Unit : mm)

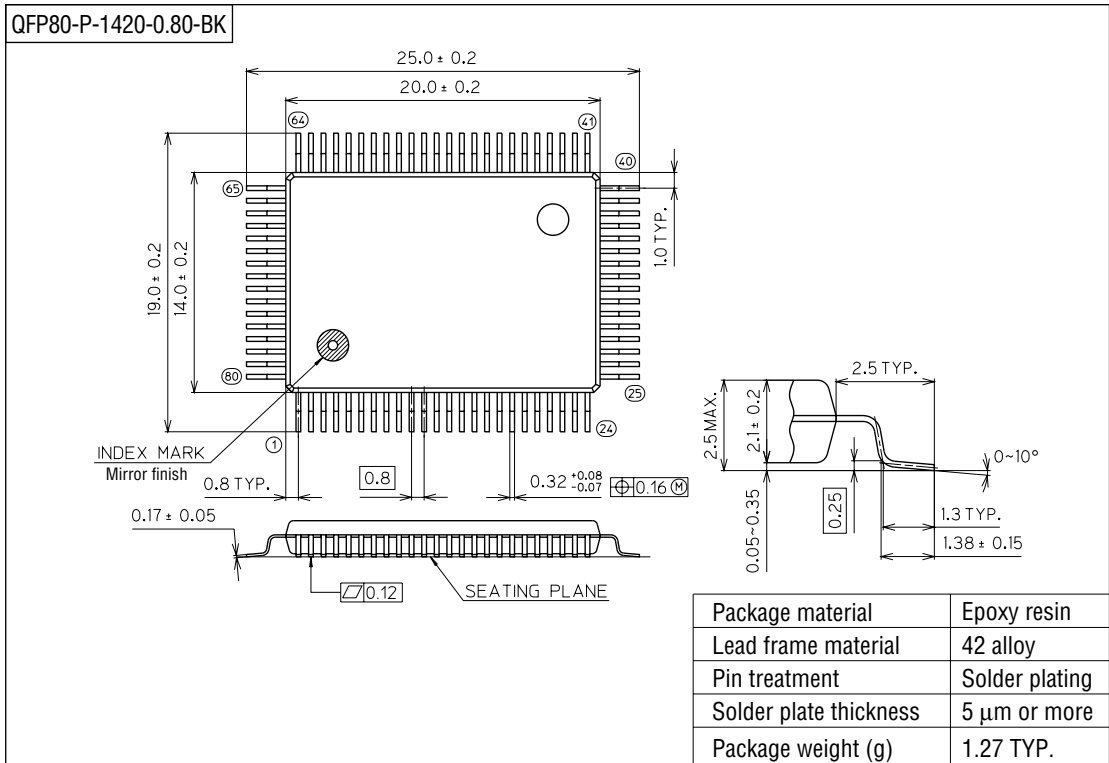

Notes for Mounting the Surface Mount Type Package

The SOP, QFP, TSOP, SOJ, QFJ (PLCC), SHP and BGA are surface mount type packages, which are very susceptible to heat in reflow mounting and humidity absorbed in storage. Therefore, before you perform reflow mounting, contact Oki's responsible sales person for the product name, package name, pin number, package code and desired mounting conditions (reflow method, temperature and times).