

OXY-LC-485 Oxygen Sensor Interface

FEATURES

- Provides the electronics necessary to power and control SST's range of dynamic oxygen (O_2) sensors.
- Communications via RS485 Modbus RTU Protocol allows complete control of the sensor operation and access to all available sensor information including diagnostics.
- Fast sensor response coupled with a very stable oxygen concentration output is achieved through adaptive software filtering.
- The oxygen sensor and interface can be calibrated in normal air (20.7% O_2) or in any other known O_2 concentration. A software delay of 5 minutes from the sensor heater being enabled prevents calibration before the sensor has reached a stable operating temperature.
- Adjustable communication settings including the ability to change the slave address of the interface allows up to 32 interfaces to communicate on the same bus. Each device presents a 'single unit load' the network. Ideal when multiple oxygen readings are required.
- Reverse voltage and transient overvoltage protection on the supply voltage lines.
- PCB mounted screw terminals for easy wiring.

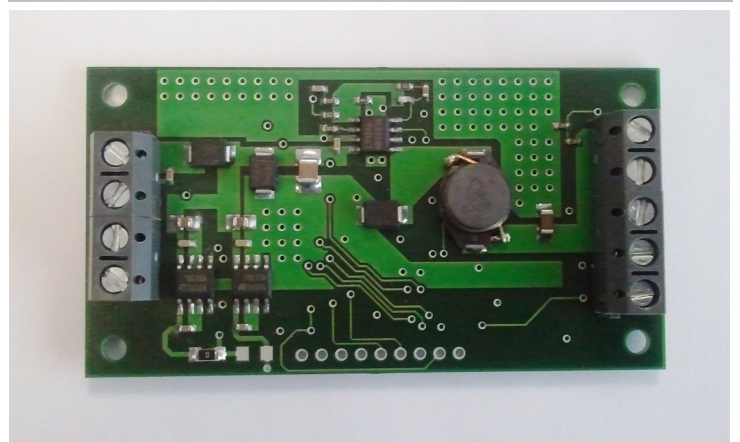
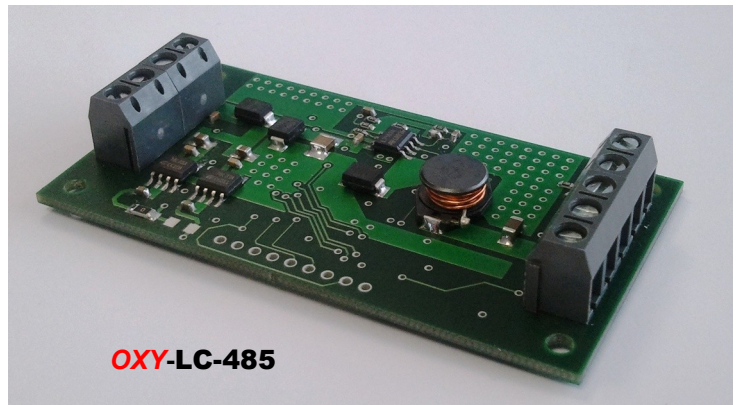

APPLICATIONS

- Combustion control including oil, gas and biomass boiler applications.
- Composting.
- Laboratory & building air quality monitoring including confined space personnel safety
- Industrial process control i.e. gas mixing for welding and steel making.
- Oxygen generation systems.
- Medical.
- Scientific including respiratory studies of a community or an organism, plants and Animals.
- Food and beverage packaging
- Applications where low oxygen is key including fermentation, rust and corrosion prevention, fire prevention, inerting and purging.

SPECIFICATIONS

Electrical

Supply voltage	8-28V _{DC}
Current consumption	600mA max @ 24V _{DC} 1.2A max @ 12V _{DC}

Temperature limits

Operating	-25 to 70°C
Storage	-40 to 85°C

OXY-LC-485 Oxygen Sensor Interface

DESCRIPTION

The OXY-LC-485 Interface provides all necessary electronics to power and control SST Sensing's range of dynamic Oxygen Sensors.

SST's range of oxygen sensors do not directly measure the oxygen concentration but instead measure the partial pressure of oxygen within the measurement gas. In order to output an oxygen concentration (%) the OXY-LC-485 must be calibrated, or more specifically, re-referenced in a known gas concentration which is typically normal air.

Calibration, or re-referencing, is initiated via Modbus as are all the sensor controls. The fixed reference is factory set to 20.7% O₂ for calibration in normal air though this value may be changed to any other known oxygen concentration which is required when using certified calibration gases.

Regular calibration removes the effects of application and atmospheric pressure changes and also eliminates any sensor drift that may occur during the first few hundred hours of operation. For maximum accuracy it is recommended that a calibration should occur every time the sensor is known to be in fresh air.

All sensor information and controls available via Modbus are described further on pages 5 to 7.

For more detailed information on the operation of SST Sensing Oxygen Sensors please refer to the following application note via our website:

AN0043 Operation Principle and Construction of Zirconium Dioxide Oxygen Sensor.

PERFORMANCE CHARACTERISTICS

Characteristics	Min.	Typ.	Max.	Unit
Output inactive start up delay (heater warm up)		60		s
Initial warm up time (till stable output)	5	10		min
Measurement Range	0.1 ⁽¹⁾		100	% O ₂
Accuracy After Calibration ⁽²⁾⁽³⁾			1	% O ₂
Repeatability After Calibration ⁽²⁾			0.5	% O ₂
Output Resolution			0.01	% O ₂
Interface reaction time to oxygen changes ⁽⁴⁾			1	s

Notes:

- (1) Prolonged operation below 0.1% O₂ can damage the sensing element and must be avoided.
- (2) Assuming barometric pressure remains constant.
- (3) As the O₂ sensor measures the partial pressure of oxygen (PPO₂) within the measurement gas deviations in the Barometric Pressure (BP) from that present during calibration will cause readout errors proportional to the change. For example if the sensor was reading 21% O₂ at 1013.25mbar and the BP increased by 1% the sensor readout would also increase by 1% to 21.21% O₂.
- (4) 10-90% response time is determined by the attached oxygen sensor. Standard sensor responses are 4s and 15s.

OXY-LC-485 Oxygen Sensor Interface

OUTLINE DRAWING AND MOUNTING INFORMATION

(All dimensions are in mm)

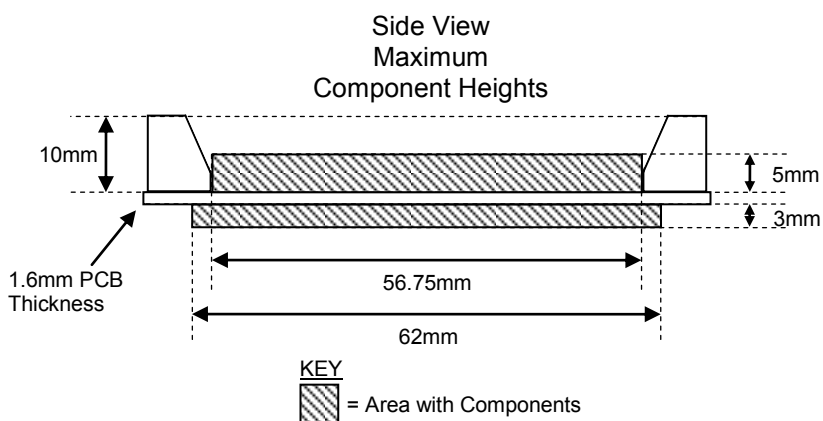
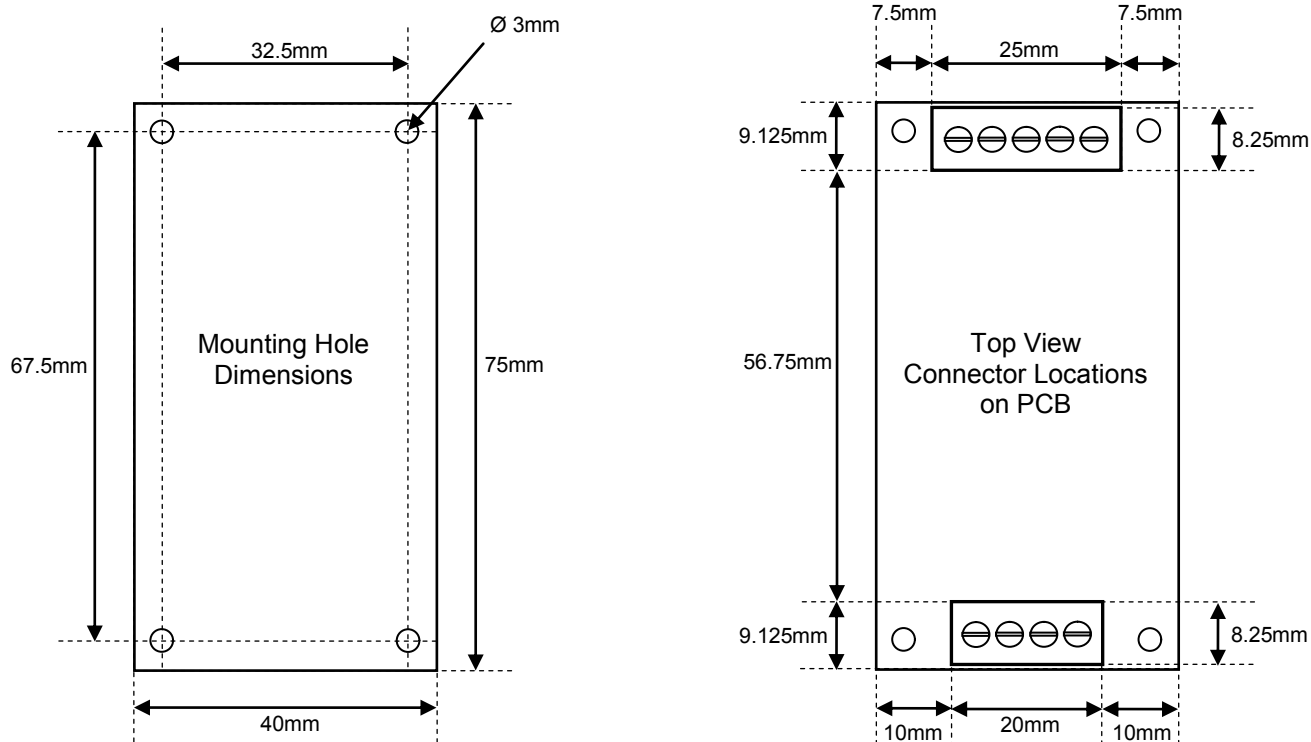

OXY-LC-485 Oxygen Sensor Interface

ELECTRICAL CONNECTIONS

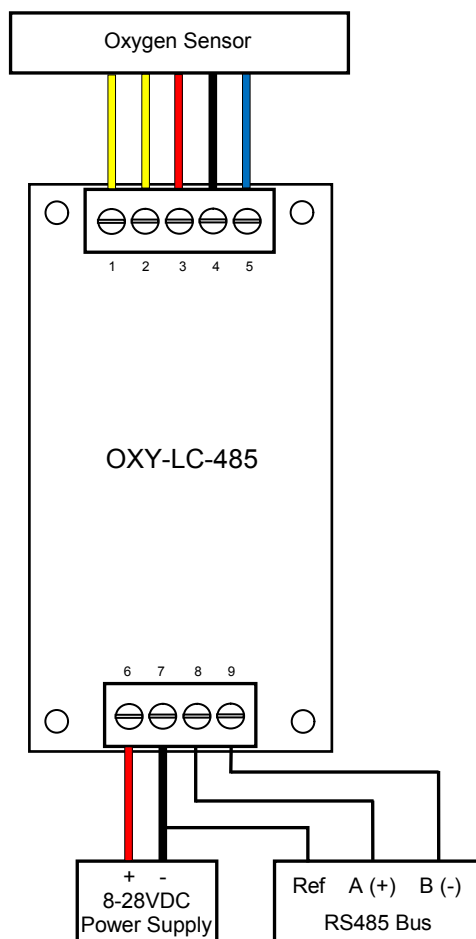

PIN	Description
1	Sensor Heater + (Yellow, H)
2	Sensor Heater GND (Yellow, H)
3	Sensor Pump (Red, P)
4	Sensor Common (Black, C)
5	Sensor Sense (Blue, S)
6	8-28V _{DC}
7	GND
8	RS485 A (+)
9	RS485 B (-)

Notes:

1. RS485 A and B (pins 8 and 9) are referenced to the power supply GND (pin 7). A connection should be made between pin 7 and the reference or common connection of the RS485 Bus.
2. Care should be taken when connecting the RS485 A and B connections to your system. The EIA-485 signalling specification states that signal **A** is the **inverting** or '-' pin and signal **B** is the **non-inverting** or '+' pin. This is in conflict with the A and B naming used by a number of differential transceiver manufacturers, including the transceiver used in the OXY-LC-485 interface. Therefore always ensure the '+' of the OXY-LC-485 interface is connected to the '+' input of the RS485 Bus and the '-' of the OXY-LC-485 interface is connected to the '-' input of the RS485 Bus.
3. Every SST oxygen sensor has two heater connections which should be connected to pins 1 & 2 of the OXY-LC-485, the heater coil has no polarity. However when connecting to a sensor where the sensor housing is one of the heater connections, pin 2 of the OXY-LC-485 should be connected to the housing.

OXY-LC-485 Oxygen Sensor Interface

MODBUS REGISTERS SPECIFICATIONS AND DESCRIPTIONS

Input Registers

Name	Register Address	Description	Action
O2% Average	0x7531 (30001)	= x / 100 % (Where: 0 = 0%, 2070 = 20.70%) Output uses an adaptive filtering method to ensure maximum stability and response to oxygen changes	Monitor in system
O2% Raw	0x7532 (30002)	= x / 100 % (Where: 0 = 0%, 2070 = 20.70%) Instantaneous oxygen reading	No action
Asymmetry	0x7533 (30003)	= x / 1000 (Where: 1000 = 1.000, 1023 = 1.023)	Monitor in system (See Modbus Note 1)
System Status	0x7534 (30004)	0 = Idle 1 = Start up routine 2 = Operating 3 = Shut down routine	Monitor in system
Error/ Warnings	0x7535 (30005)	Bit 0 (LSB) = Pump Error Bit 1 = Heater Voltage Error Bit 2 = Asymmetry Warning Bit 3 = O2 Under 0.1% Warning	Monitor in system (See Modbus Note 1)
Heater Voltage	0x7536 (30006)	= x / 100 Volts (Where 443 = 4.43 Volts)	Monitor in system (See Modbus Note 1)
TD Average	0x7537 (30007)	= x * 0.1ms (Where 2033 = 203.3ms)	No action
TD Raw	0x7538 (30008)	= x * 0.1ms (Where 2033 = 203.3ms)	No action
TP	0x7539 (30009)	= x * 0.1ms (Where 2033 = 203.3ms)	No action
T1	0x753A (30010)	= x * 0.1ms (Where 2033 = 203.3ms)	No action
T2	0x753B (30011)	= x * 0.1ms (Where 2033 = 203.3ms)	No action
T4	0x753C (30012)	= x * 0.1ms (Where 2033 = 203.3ms)	No action
T5	0x753D (30013)	= x * 0.1ms (Where 2033 = 203.3ms)	No action

OXY-LC-485 Oxygen Sensor Interface

MODBUS REGISTERS SPECIFICATIONS AND DESCRIPTIONS

Holding Registers

Name	Register Address	Allowed Values	Default	Description	Action
Sensor ON OFF	0x9C41 (40001)	0 = Sensor Off 1 = Sensor ON	-	System Control	Set in system
Clear Error Flags	0x9C42 (40002)	0 = IDLE 1 = Clear Errors and Warnings	-	Clear all Error flags	Set in system (See Modbus Note 1)
Shutdown Delay	0x9C43 (40003)	0 - 65535	0	x seconds	Set in system (See Modbus Note 2)
Calibrate Active	0x9C44 (40004)	0 = Calibration Idle 1 = Activate Calibration	0	Calibration Activation.	Set in system (See Modbus Note 3)
Calibration (%)	0x9C45 (40005)	0 - 65535	2070	Calibration % Input (Where 20.70% is input as 2070)	Set in system (See Modbus Note 3)
Address	0x9C46 (40006)	1 - 247	1	RS485 Setup Interface Slave Address	Set in system if required (See Modbus Note 4)
Baud	0x9C47 (40007)	0 = 2400 1 = 4800 2 = 9600 3 = 19200 4 = 38400 5 = 57600 6 = 115200	2	RS485 Setup	Set in system if required (See Modbus Note 5)
Parity	0x9C48 (40008)	0 = None 1 = Odd 2 = Even	0	RS485 Setup	Set in system if required (See Modbus Note 5)
Stopbits	0x9C49 (40009)	0 = 1 1 = 2	0	RS485 Setup	Set in system if required (See Modbus Note 5)
RS485 Setup Changes Apply and Save	0x9C4A (40010)	0 = Idle 1 = Apply and Save	0	Commits any changes to the RS485 Setup registers to memory.	Set in system if required (See Modbus Note 5)

OXY-LC-485 Oxygen Sensor Interface

MODBUS NOTES

1. Hex value output should be converted to a 4bit binary value. Each bit of the 4bit word represents an error or warning as described above. This allows more than one error to be displayed at the same time.

Example; Hex value = 5, binary representation = 0101, Bit 0 = 1 (Pump Error) and Bit 3 = 1 (Asymmetry Warning).

Bits 0 and 1 are error conditions and will result in the interface being forced into its idle state which means there will be no O2 measurements. This will require the system to highlight that the O2 sensor is in a fail condition. As a first step the interface should be powered down and all wiring thoroughly checked.

Pump Error indicates that the sensor is not operational and requires replacement.

Heater Error indicates that the sensor heater voltage is not within tolerance. When this occurs there is a problem with the switch mode power supply on the interface PCB or the heater coil has gone short circuit. The Heater Voltage register can be read to confirm the error. The Heater Voltage should be typically 445 (4.45V) and the limits are 400 to 500 (4V to 5V).

Bits 3 and 4 are warnings which will not stop the interface from outputting O2 values. This will require the system to monitor the sensor outputs and highlight the warning.

An Asymmetry Warning indicates that the sensor waveform is asymmetrical which means that the O2 sensor is not operating as expected. Asymmetry should be between 0.95 and 1.05 when the sensor is in a steady atmosphere. However when the O2 level is changing the waveform period is also changing so the asymmetry value can be between 0.85 and 1.15. If the asymmetry value exceeds 0.85 to 1.15 an asymmetry warning will be set. The Asymmetry register can be read to confirm the warning and the system can highlight that the sensor needs replaced. Asymmetry errors can be generated if the sensor has reached its end of life or has been damaged through misuse as highlighted on pages 8 and 9.

O2 Under 0.1% Warning indicates when the sensor is reading less than 0.1% O2 which has the potential to damage the sensor. This is highly unlikely in boiler applications but has to be avoided.

The error and warning flags can be cleared by setting the Clear Error Flags register to '1'. This register will return to 0 when the clear has been completed.

2. The shutdown delay allows the heater voltage to remain on after the sensor has stopped taking measurements. This should be used in applications where there is high humidity and especially if there is also aggressive components in the measurement gas (See Page 8). By applying a shutdown delay the heater can keep the sensor hot until the rest of the application has cooled down. This encourages condensation to form elsewhere and not on the sensor which could lead to corrosion of the sensing cell. The length of the delay in seconds should be set to suit the application cool down time.
3. Calibration should occur when the O2 sensor is known to be in the calibration gas, which is normally fresh air, for at least 5 minutes. In boiler applications this happens when the ventilation fan is flushing the system with fresh air which is typically 20.7% O2. At this point 2070 (20.70%) is input into the Calibration (%) holding register then Calibrate Active register is set to '1'. The interface will only calibrate after the sensor has been switched on (heater active) for more than five minutes. The calibration status can be monitored by reading back the Calibrate Active register which will remain at '1' until the calibration process is complete at which point it will return to '0' (Calibration Idle). New Calibration values are retained on power loss.
4. The Address register allows the interface slave address to be changed between 1 and 247. This is only applicable if there are multiple OXY-LC-485 interfaces or other devices on the same communication lines.
5. The communication settings can be adjusted to suit the application. Changes are only implemented when the RS485 Setup Changes Apply and Save holding register is set to '1'. After applying new settings communications will be lost until the master is reconfigured to the new settings. Any changes made are retained on power loss.

OXY-LC-485 Oxygen Sensor Interface

SENSOR OPERATING TIPS

To get the best performance from the OXY-LC-485 interface it is important that the attached oxygen sensor is installed and maintained in the correct manner. The following two pages outline some useful sensor operating tips and a list of gases and materials that must be avoided to ensure a long sensor life.

Operating the Sensor in Aggressive Humid Environments:

When operating the sensor in warm, humid environments it is important the sensor remains at a higher temperature than it's surroundings, especially if there are corrosive components in the measurement gas. During operation this is not a problem due the 700°C generated by the heater, but this means when the sensor or application is being powered down the sensor heater must be the last thing to be turned off after the temperature of the surroundings have suitably cooled. Ideally the sensor should be left powered at all times in very humid environments.

Failure to adhere to the above will result in condensation forming on the heater and sensing cell as these will be the first components to cool due to their connections to the outside world. When the sensor is re-powered the condensation will evaporate, leaving behind corrosive salts which very quickly destroy the heater and cell as illustrated below. Note how the sensor's external metalwork looks completely normal.



Protecting from Water Droplets:

In environments where falling water droplets are likely the sensor should be protected from water falling directly onto the very hot sensor cap as this can cause massive temperature shocks to the cell and heater. Popular methods include a hood over the sensor cap or for the sensor to be mounted in a larger diameter cylinder.

At a very minimum the sensor cap should be angled downwards in the application as this will deflect any falling moisture and prevent the sensor cap from filling with water.

Using the Sensor With Silicones:

SST Sensing's oxygen sensors, like all other Zirconium Dioxide sensors, are damaged by the presence of silicone in the measurement gas. Vapours (organic silicone compounds) of RTV rubbers and sealants are the main culprits and are widely used in many applications. These materials which are often applied as a liquid or gel still outgas silicone vapours into the surrounding atmosphere even after they have cured. When these vapours reach the sensor the organic part of the compound will be burned at hot sensor parts, leaving behind a very fine divided Silicon Dioxide (SiO_2). This SiO_2 completely blocks the pores and active parts of the electrodes.

If silicone cannot be avoided in the application we advise using high quality, high temperature cured materials which do not outgas when subsequently heated. SST can provide guidance if there is concern about use of silicone within the application.

When installing the sensor do not use any lubricants or grease which may contain silicone.

In addition to silicones other gases which may interfere with the sensor are listed overleaf.

OXY-LC-485 Oxygen Sensor Interface

SENSOR OPERATING TIPS continued

Cross sensitivity with other gases:

Gases or chemicals that will have an influence on the life of the sensor or on the measuring results are:

1. Combustible Gases

Small amounts of combustible gases will be burned at the hot Pt-electrode surfaces or Al₂O₃ filters of the sensor. In general combustion will be stoichiometric as long as enough oxygen is available, the sensor will measure the residual oxygen pressure which leads to a measurement error. The sensor is not recommended for use in applications where there are large amounts of combustible gases present and an accurate O₂ measurement is required.

Investigated gases were:

- H₂ (Hydrogen) up to 2%; stoichiometric combustion
- CO (Carbon Monoxide) up to 2%; stoichiometric combustion
- CH₄ (Methane) up to 2.5%; stoichiometric combustion
- NH₃ (Ammonia) up to 1500 ppm; stoichiometric combustion

2. Heavy Metals

Vapours of metals like Zn (Zinc), Cd (Cadmium), Pb (Lead), Bi (Bismuth) will have an effect on the catalytic properties of the Pt- electrodes. Exposure to these metal vapours must be avoided.

3. Halogen and Sulphur Compounds

Small amounts (< 100ppm) of Halogens and/or Sulphur compounds have no effect on the performance of the oxygen sensor. Higher amounts of these gases will in time cause readout problems or, especially in condensing atmospheres, corrosion of sensor parts. These gases often outgas from plastic housings and tubes when hot.

Investigated gases were:

- Halogens, F₂ (Flourine), Cl₂ (Chlorine)
- HCL (Hydrogen Chloride), HF (Hydrogen Fluoride)
- SO₂ (Sulphur Dioxide)
- H₂S (Hydrogen Sulphide)
- Freons
- CS₂ (Carbon Disulfide)

4. Reducing Atmospheres

Long time exposure to reducing atmospheres may in time impair the catalytic effect of the Pt-electrodes and has to be avoided. Reducing atmospheres are defined as an atmosphere with very little free oxygen and where combustible gases are present. In this type of atmosphere oxygen is consumed as the combustible gases are burned.

5. Others

- Dust. Fine dust (Carbon parts/soot) might cause clogging of the porous stainless steel filter and might have an effect on the response of the sensor to oxygen changes.
- Heavy shocks or vibrations may alter sensor properties resulting in the need for a recalibration.

WARNING

Due to the power requirements of the sensor heater the PCB becomes HOT during operation.

Personal Injury

DO NOT USE these products as safety or Emergency Stop devices or in any other application where failure of the product could result in personal injury.

Failure to comply with these instructions could result in death or serious injury.

CAUTION

Do not exceed maximum ratings and ensure sensor is operated in accordance with all requirements of AN0043
Failure to comply with these instructions may result in product damage.