

TGS 2444 - for the detection of Ammonia

Features:

- * Low power consumption
- * High sensitivity/selectivity to ammonia (NH₃)
- * Miniature size

Applications:

- * Ammonia leak detection in refrigerators
- * Ventilation control for agricultural and poultry industries

TGS 2444 utilizes a multilayer sensor structure. A glass layer for thermal insulation is printed between a ruthenium oxide (RuO₂) heater and an alumina substrate. A pair of Au electrodes for the heater are formed on a thermal insulator. The gas sensing layer, which is formed of tin dioxide (SnO₂), is printed on an electrical insulation layer which covers the heater. A pair of Au electrodes for measuring sensor resistance are formed on the electrical insulator. Activated charcoal is filled between the internal cover and the outer cover for the purpose of reducing the influence of noise gases.

TGS 2444 displays good selectivity to ammonia, making it ideal for critical safety-related applications such as the detection of ammonia leaks in refrigeration systems and ammonia detection in the agricultural field. In the presence of ammonia, the sensor's conductivity increases depending on the gas concentration in the air. A simple pulsed electrical circuit operating on a one second circuit voltage cycle can convert the change in conductivity to an output signal which corresponds to gas concentration.

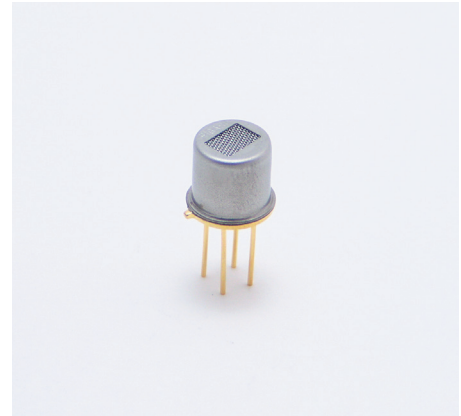

The figure below represents typical sensitivity characteristics, all data having been gathered at standard test conditions (see reverse side of this sheet). The Y-axis is indicated as sensor resistance ratio (Rs/Ro) which is defined as follows:

$$R_s = \text{Sensor resistance of displayed gases at various concentrations}$$

$$R_o = \text{Sensor resistance in air}$$

The figure below represents typical temperature and humidity dependency characteristics. Again, the Y-axis is indicated as sensor resistance ratio (Rs/Ro), defined as follows:

$$R_s = \text{Sensor resistance in 10ppm of ammonia}$$

$$R_o = \text{Sensor resistance in air}$$

Sensitivity Characteristics:

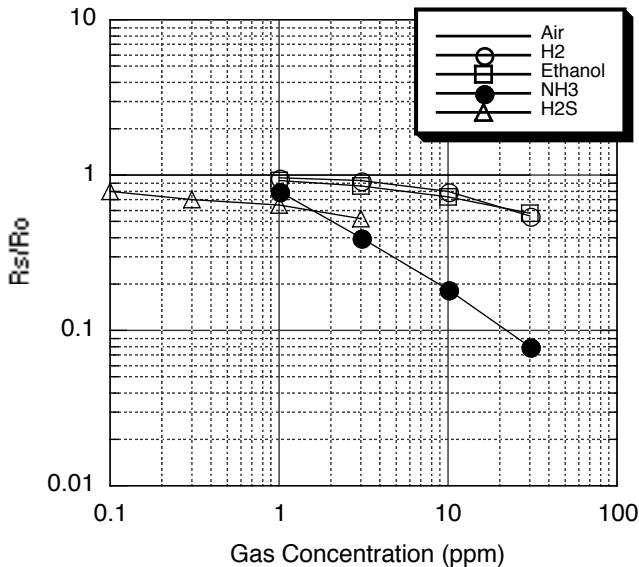

Sensor Response Pattern:

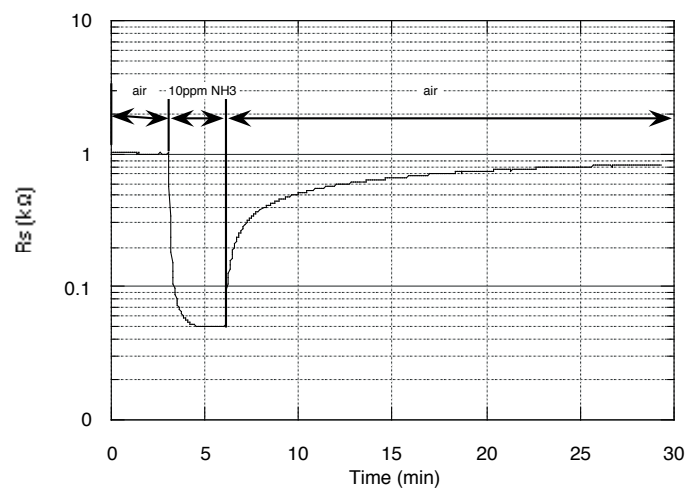

IMPORTANT NOTE: OPERATING CONDITIONS IN WHICH FIGARO SENSORS ARE USED WILL VARY WITH EACH CUSTOMER'S SPECIFIC APPLICATIONS. FIGARO STRONGLY RECOMMENDS CONSULTING OUR TECHNICAL STAFF BEFORE DEPLOYING FIGARO SENSORS IN YOUR APPLICATION AND, IN PARTICULAR, WHEN CUSTOMER'S TARGET GASES ARE NOT LISTED HEREIN. FIGARO CANNOT ASSUME ANY RESPONSIBILITY FOR ANY USE OF ITS SENSORS IN A PRODUCT OR APPLICATION FOR WHICH SENSOR HAS NOT BEEN SPECIFICALLY TESTED BY FIGARO.

Basic Measuring Circuit:

Circuit voltage (Vc) is applied across the sensing element which has a resistance (Rs) between the sensor's two electrodes (pins No. 2 and No. 3) and a load resistor (RL) connected in series. The sensing element is heated by the heater which is connected to pins No. 1 and No. 4.

Heating cycle--The sensor requires application of a 250 msec heating cycle which is used in connection with a circuit voltage cycle of 250 msec. Each Vh cycle is comprised by 4.8V being applied to the heater for the first 14ms, followed by 0V pulse for the remaining 236ms. The Vc cycle consists of 0V applied for 2msec, followed by 5.0V for 5ms and 0V for 243msec. For achieving optimal sensing

characteristics, the sensor's signal should be measured after the midpoint of the 5ms Vc pulse of 5.0V (for reference, see timing chart below).

NOTE: Application of a Vc pulse condition is required to prevent possible migration of heater materials into the sensing element. Under extreme conditions of high humidity and temperature, a constant Vc condition could result in such migration and cause long term drift of Rs to higher values. A 5ms Vc pulse results in significantly less driving force for migration than a constant Vc condition, rendering the possibility of migration negligibly small.

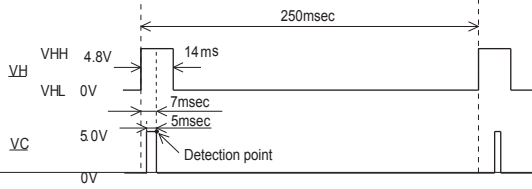
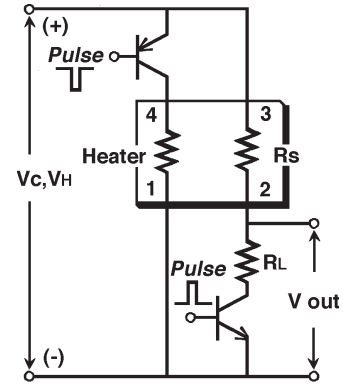

Structure and Dimensions:

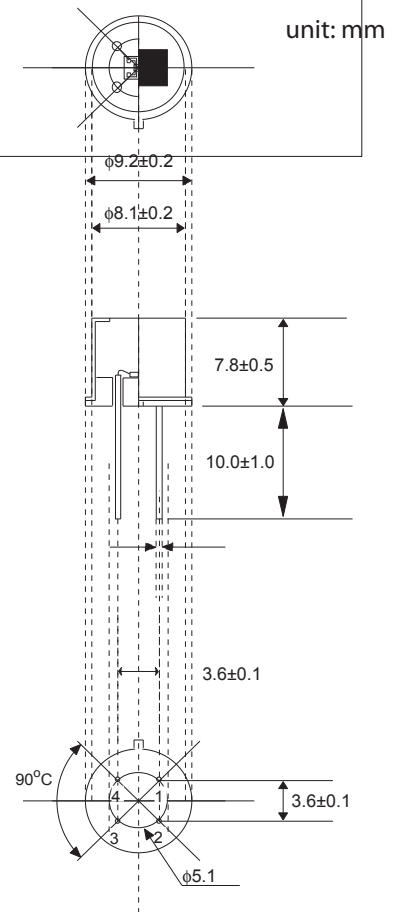

- Pin connections:
 1: Heater
 2: Sensor (-)
 3: Sensor (+)
 4: Heater

Specifications:

Model number		TGS 2444	
Sensing element type		M1	
Standard package		TO-5 metal can	
Target gases		Ammonia	
Typical detection range		10 ~ 100 ppm	
Standard circuit conditions	Heater voltage cycle	VH	VHH=4.8V±0.2V DC, 14ms VHL=0.0, for 236ms
	Circuit voltage cycle	Vc	Vc=0V for 245ms, Vc=5.0V±0.2V DC for 5ms (see timing chart for measurement timing)
	Load resistance	RL	variable Ps ≥ 8kΩ
Electrical characteristics under standard test conditions	Heater resistance	RH	17 ± 2.5Ω at room temp.
	Heater current	IH	approx. 203mA(in case of VHH)
	Heater power consumption	PH	56mW (typical)
	Sensor resistance	Rs	3.63kΩ ~ 36.3kΩ in 10ppm of ammonia
	Sensitivity (change ratio of Rs)	β	0.0.63 ~ 0.63
Standard test conditions	Test gas conditions	Ammonia in air at 20±2°C, 65±5%RH	
	Circuit conditions	Same as Std. Circuit Condition (above)	
	Conditioning period before test	≥ 48 hours	
Operating conditions	-10°C~+50°C w/o dew condensation Less than absolute humidity corresponds to 40°C/80%RH		
Storage conditions	-20°C~+60°C w/o dew condensation Less than absolute humidity corresponds to 60°C/90%RH		

Sensor resistance (Rs) is calculated with a measured value of Vout as follows:

$$R_s = \frac{V_c \cdot R_L}{V_{out}} - R_L$$