

Basic Switch

V

General Purpose Basic Switch

- Applications include not only industrial equipment but also commercial products (OEM)
- Low force, high contact reliability design available (Type name VX)



Ordering Information

■ **THERMOSET MATERIAL**

(●: standard. ○: available on request)

Remarks	Ratings	Common Terminal position	Contact Gap		Terminal Shape (see note)					OF max.					Part Number
			1 mm	0.5 mm	A	C2	C	B	E	15	25	100	200	400	
Mounted with 2.9 mm dia. screws. The switch unit is housed in a thermoset case, and has high versatility in applications.	15 A, 250 V	Bottom	○	●	●	●	○	○	○	—	—	○	●	○	V-15
	10 A, 250 V	Bottom	○	●	●	●	○	○	○	—	—	●	●	—	V-10

- Note: 1. A: Solder/quick connect terminal (#187)
 C2: Quick connect terminal (#187)
 C: Quick connect terminal (#250)
 B: Screw terminal
 E: Solder terminal
 E2: Short solder terminals in 10 and 15 A versions.
 2. Low force, high contact reliability design available (Type name VX).



Actuator	Common Terminal Position	Contact Form	Connect Terminal	Part Number		
				Rated Current		
				15 A	10 A	
				200 grams	200 grams	100 grams
Pin plunger	Bottom	SPDT	A	V-15G-1A5-K	V-10G-1A5-K	V-10G-1A4-K
			C2	V-15G-1C25-K	V-10G-1C25-K	V-10G-1C24-K
			C	V-15G-1C5-K	-	-
			B	V-15G-1B5-K	V-10G-1B5-K	V-10G-1B4-K
			E	V-15G-1E5-K	V-10G-1E5-K	V-10G-1E4-K
		SPST-NC	A	V-15G-2A5-K	V-10G-2A5-K	V-10G-2A4-K
			C2	V-15G-2C25-K	V-10G-2C25-K	V-10G-2C24-K
			C	V-15G-2C5-K	-	-
		SPST-NO	A	V-15G-3A5-K	V-10G-3A5-K	V-10G-3A4-K
	C2		V-15G-3C25-K	V-10G-3C25-K	V-10G-3C24-K	
	C		V-15G-3C5-K	-	-	
	Side	SPDT	A	V-15G-4A5-K	V-10G-4A5-K	V-10G-4A4-K
A			V-15G-5A5-K	V-10G-5A5-K	V-10G-5A4-K	
A			V-15G-6A5-K	V-10G-6A5-K	V-10G-6A4-K	
Short hinge lever	Bottom	SPDT	A	V-15G1-1A5-K	V-10G1-1A5-K	V-10G1-1A4-K
			C2	V-15G1-1C25-K	V-10G1-1C25-K	V-10G1-1C24-K
			B	V-15G1-1B5-K	V-10G1-1B5-K	V-10G1-1B4-K
			E	V-15G1-1E5-K	V-10G1-1E5-K	V-10G1-1E4-K
Hinge lever	Bottom	SPDT	A	V-15G2-1A5-K	V-10G2-1A5-K	V-10G2-1A4-K
			C2	V-15G2-1C25-K	V-10G2-1C25-K	V-10G2-1C24-K
			B	V-15G2-1B5-K	V-10G2-1B5-K	V-10G2-1B4-K
			E	V-15G2-1E5-K	V-10G2-1E5-K	V-10G2-1E4-K
Long hinge lever	Bottom	SPDT	A	V-15G3-1A5-K	V-10G3-1A5-K	V-10G3-1A4-K
			C2	V-15G3-1C25-K	V-10G3-1C25-K	V-10G3-1C24-K
			B	V-15G3-1B5-K	V-10G3-1B5-K	V-10G3-1B4-K
			E	V-15G3-1E5-K	V-10G3-1E5-K	V-10G3-1E4-K
Formed hinge lever	Bottom	SPDT	A	V-15G4-1A5-K	V-10G4-1A5-K	V-10G4-1A4-K
			C2	V-15G4-1C25-K	V-10G4-1C25-K	V-10G4-1C24-K
			B	V-15G4-1B5-K	V-10G4-1B5-K	V-10G4-1B4-K
			E	V-15G4-1E5-K	V-10G4-1E5-K	V-10G4-1E4-K
Short hinge roller lever	Bottom	SPDT	A	V-15G5-1A5-K	V-10G5-1A5-K	V-10G5-1A4-K
			C2	V-15G5-1C25-K	V-10G5-1C25-K	V-10G5-1C24-K
			B	V-15G5-1B5-K	V-10G5-1B5-K	V-10G5-1B4-K
			E	V-15G5-1E5-K	V-10G5-1E5-K	V-10G5-1E4-K
Hinge roller lever	Bottom	SPDT	A	V-15G6-1A5-K	V-10G6-1A5-K	V-10G6-1A4-K
			C2	V-15G6-1C25-K	V-10G6-1C25-K	V-10G6-1C24-K
			B	V-15G6-1B5-K	V-10G6-1B5-K	V-10G6-1B4-K
			E	V-15G6-1E5-K	V-10G6-1E5-K	V-10G6-1E4-K

Note: 1. For thermoplastic material, replace the "15" or "10" (Amps) in the above part numbers with "16" and "11" (Amps), respectively.
 2. 21 A version also available in thermoplastic material only. Please consult Omron.
 3. An insulation barrier is available upon request for thermoplastic types.



CONTACT FORM

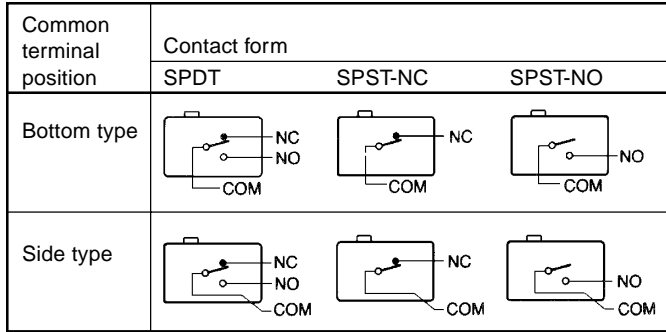

Application load range

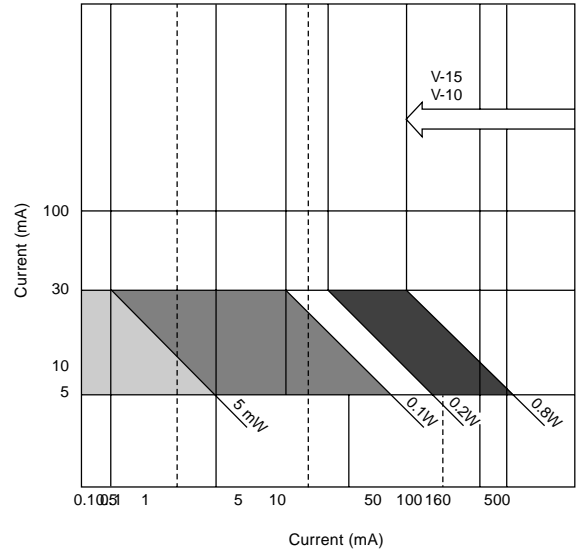

Specifications

Type	Rated voltage	Non-inductive load (A)				Inductive load (A)				Inrush current Non-inductive & Inductive NC/NO
		Resistive load		Lamp load		Inductive load		Motor load		
		NC	NO	NC	NO	NC	NO	NC	NO	
15 A	250 VAC	15	15	2	2	10	10	3	3	36 A max.
	8 VDC	15	15	4	4	10	10	6	6	
	30 VDC	10	10	4	4	10	10	4	4	
	125 VDC	0.6	0.6	0.1	0.1	0.6	0.6	0.1	0.1	
	250 VDC	0.3	0.3	0.05	0.05	0.3	0.3	0.05	0.05	
10 A	250 VAC	10	10	1.5	1.5	6	6	2	2	24 A max.
	8 VDC	10	10	3	3	6	6	3	3	
	30 VDC	6	6	3	3	6	6	3	3	
	125 VDC	0.6	0.6	0.1	0.1	0.6	0.6	0.1	0.1	
	250 VDC	0.3	0.3	0.05	0.05	0.3	0.3	0.05	0.05	

- Note: 1. Inductive load has a power factor of 0.4 min. (AC) and a time constant of 7 milliseconds max. (DC).
 2. Lamp load has an inrush current of 10 times the steady-state current, while motor load has an inrush current of 6 times the steady-state current.
 3. The specifications shown in the above table apply to the types with a contact gap of 1 mm.



Characteristics

		V-15	V-10
Operating speed		0.1 mm to 1 m/second (0.004 to 39.4 in/second) at pin plunger	
Operating frequency	Mechanical	600 operations per minute	
	Electrical	60 operations per minute	
Contact resistance		15 mΩ max. (initial)	30 mΩ max. (initial)
Insulation resistance		100 MΩ min. at 500 VDC	
Dielectric strength (VAC)		1,000 VAC, between non-continuous terminals 1,500 VAC, between each terminal and ground	
Vibration (see note 2)	Malfunction durability	10 to 55 Hz, 1.5 mm double amplitude	
Shock (see note 2)	Mechanical durability	1,000 m/s ² min. (approx. 100 g)	
	Malfunction durability	300 m/s ² min. (approx. 30 g)	200 m/s ² min. (approx. 20 g)
Ambient temperature	Operating	-25° to 80°C (-20° to 150°C for heat resistant type)	
Humidity	Operating	85% RH max.	
Service life	Mechanical	50,000,000 operations min.	
	Electrical	100,000 operations min.	300,000 operations min.
Weight		Approx. 6.2 g (pin plunger type)	

Note: 1. Data shown are of initial value.
2. The values indicated here are of the pin plunger type.

CHARACTERISTIC DATA

Mechanical service life V-15, V-10

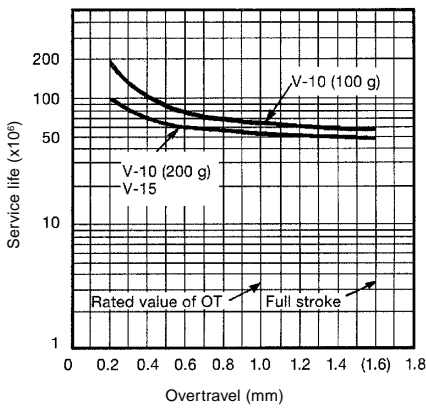

Electrical service life V-15

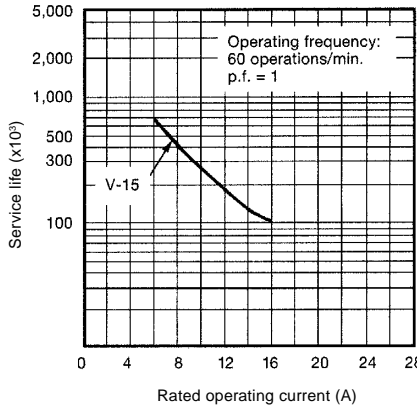

Electrical service life V-10

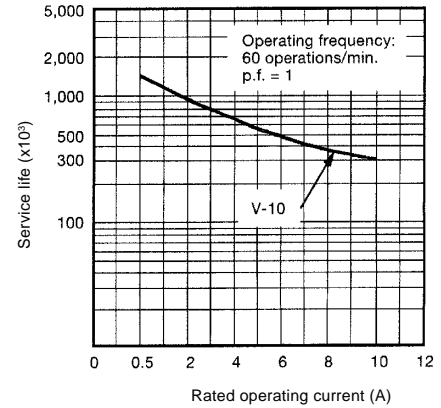

Dust resistivity test

Condition: The sample is left in a room which contains about 2 kg of particles per 1 m³. A particle can pass through a square net having a line diameter of 50 μm and a gap of 75 μm.

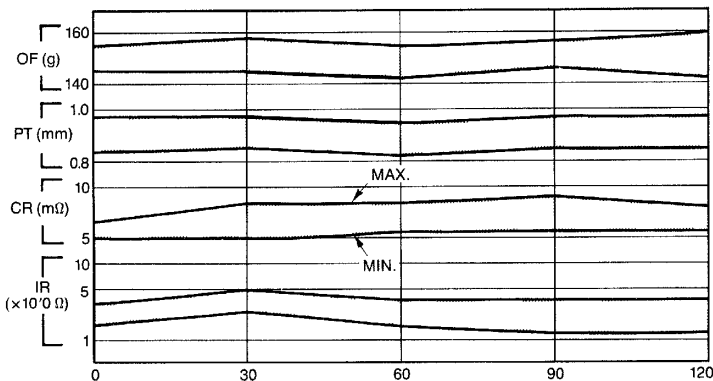

Water spray test

Condition: The sample is subjected to water sprayed from every direction in a range of ±60° from the right angle at a precipitation of 10 to 20 mm/min.

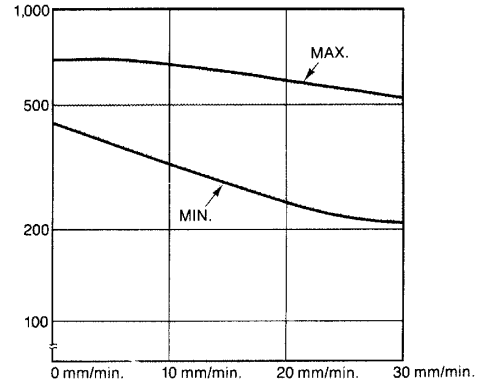



Dimensions

Unit: mm (inch)

The following figures show the models having quick connect terminals in the #250 series at the bottom of the case. For other terminals, please refer to "Terminals."

V-15G-1□5-K
V-10G-1□5-K
V-10G-1□4-K

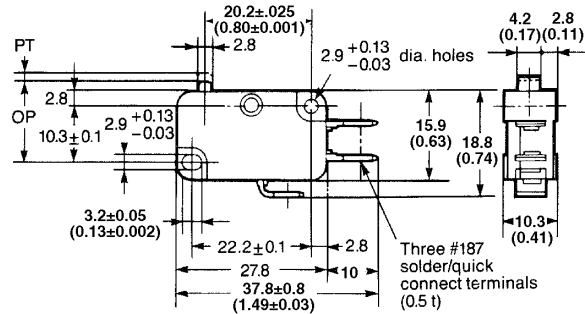

Operating characteristics	200 grams	100 grams
	V-15G-1□5-K V-10G-1□5-K	V-10G-1□4-K
OF max.	200 g	100 g
RF min.	50 g	20 g
PT max.	1.2 mm (0.05 in)	1.2 mm (0.05 in)
OT min.	1.3 mm (0.05 in)	1.3 mm (0.05 in)
MD max.	0.3 mm (0.01 in)	0.3 mm (0.01 in)
OP	14.7±0.4 mm (0.58±0.02 in)	14.7±0.4 mm (0.58±0.02 in)

V-15G1-1□5-K
V-10G1-1□5-K
V-10G1-1□4-K

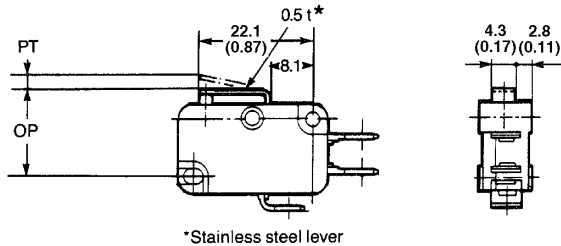

Operating characteristics	200 grams	100 grams
	V-15G1-1□5-K V-10G1-1□5-K	V-10G1-1□4-K
OF max.	200 g	100 g
RF min.	50 g	15 g
PT max.	1.5 mm (0.06 in)	1.5 mm (0.06 in)
OT min.	1.0 mm (0.04 in)	1.0 mm (0.04 in)
MD max.	0.5 mm (0.02 in)	0.5 mm (0.02 in)
OP	15.2±0.5 mm (0.60±0.02 in)	15.2±0.5 mm (0.60±0.02 in)

V-15G2-1□5-K
V-10G2-1□5-K
V-10G2-1□4-K

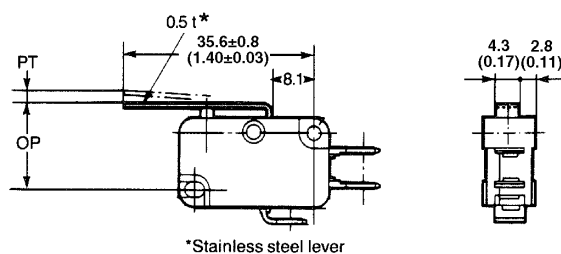

Operating characteristics	200 grams	100 grams
	V-15G2-1□5-K V-10G2-1□5-K	V-10G2-1□4-K
OF max.	125 g	60 g
RF min.	14 g	6 g
PT max.	2.3 mm (0.09 in)	3.3 mm (0.13 in)
OT min.	2.3 mm (0.09 in)	2.3 mm (0.09 in)
MD max.	0.8 mm (0.03 in)	0.8 mm (0.03 in)
OP	15.2 ^{+2.6} _{-3.2} mm (0.60 ^{+0.10} _{-0.13} in)	15.2±1.2 mm (0.60±0.05 in)

V-15G3-1□5-K
V-10G3-1□5-K
V-10G3-1□4-K

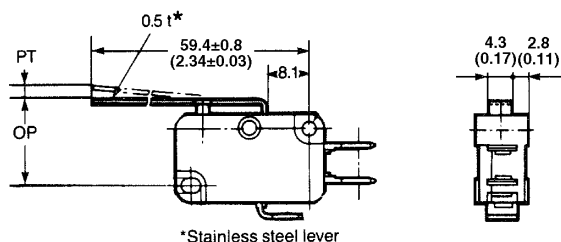

Operating characteristics	200 grams	100 grams
	V-15G3-1□5-K V-10G3-1□5-K	V-10G3-1□4-K
OF max.	70 g	35 g
RF min.	6 g	—
PT max.	9.0 mm (0.24 in)	7.6 mm (0.30 in)
OT min.	3.0 mm (0.12 in)	3.2 mm (0.13 in)
MD max.	2.0 mm (0.08 in)	2.0 mm (0.08 in)
OP	15.2±2.6 mm (0.60±0.10 in)	15.2±2.6 mm (0.60±0.10 in)

Note: Unless otherwise specified, a tolerance of ± 0.4 mm applies to all dimensions.



Unit: mm (inch)

The following figures show the models having quick connect terminals in the #250 series at the bottom of the case. For other terminals, please refer to "Terminals."

V-15G4-1□5-K
V-10G4-1□5-K
V-10G4-1□4-K

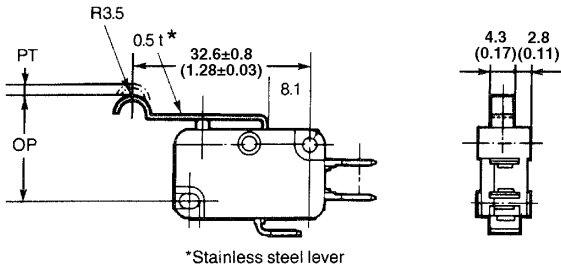

Operating characteristics	200 grams	100 grams
		V-15G4-1□5-K V-10G4-1□5-K
OF max.	125 g	60 g
RF min.	14 g	6 g
PT max.	3.3 mm (0.13 in)	3.3 mm (0.13 in)
OT min.	2.3 mm (0.09 in)	2.3 mm (0.09 in)
MD max.	0.8 mm (0.03 in)	0.8 mm (0.03 in)
OP	18.7±1.2 mm (0.74±0.05 in)	18.7±1.2 mm (0.74±0.05 in)

V-15G5-1□5-K
V-10G5-1□5-K
V-10G5-1□4-K

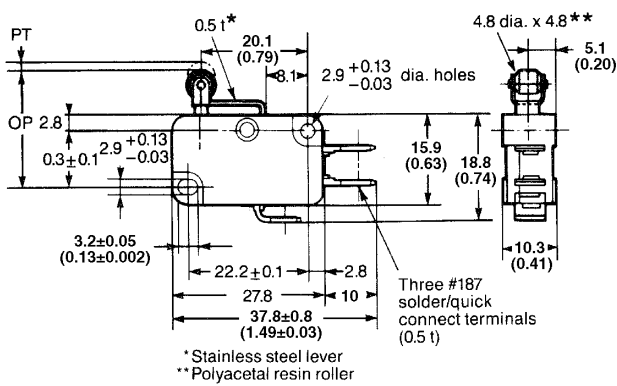

Operating characteristics	200 grams	100 grams
		V-15G5-1□5-K V-10G5-1□5-K
OF max.	240 g	120 g
RF min.	50 g	15 g
PT max.	1.5 mm (0.06 in)	1.5 mm (0.06 in)
OT min.	1.0 mm (0.04 in)	1.0 mm (0.04 in)
MD max.	0.5 mm (0.02 in)	0.5 mm (0.02 in)
OP	20.7±0.6 mm (0.81±0.02 in)	20.7±0.6 mm (0.81±0.02 in)

V-15G6-1□5-K
V-10G6-1□5-K
V-10G6-1□4-K

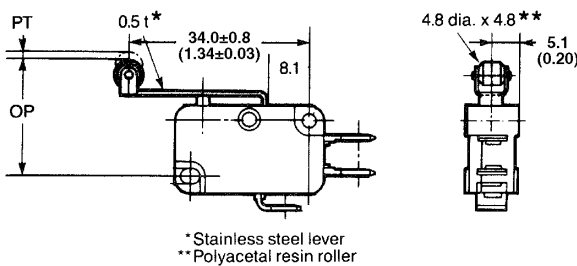

Operating characteristics	200 grams	100 grams
		V-15G6-1□5-K V-10G6-1□5-K
OF max.	125 g	60 g
RF min.	14 g	6 g
PT max.	3.3 mm (0.13 in)	3.3 mm (0.13 in)
OT min.	2.3 mm (0.09 in)	2.3 mm (0.09 in)
MD max.	0.8 mm (0.03 in)	0.8 mm (0.03 in)
OP	20.7±1.6 mm (0.81±0.06 in)	20.7±1.6 mm (0.81±0.06 in)

Note: Unless otherwise specified, a tolerance of ± 0.4 mm applies to all dimensions.



■ TERMINALS

Unit: mm (inch)

General purpose type

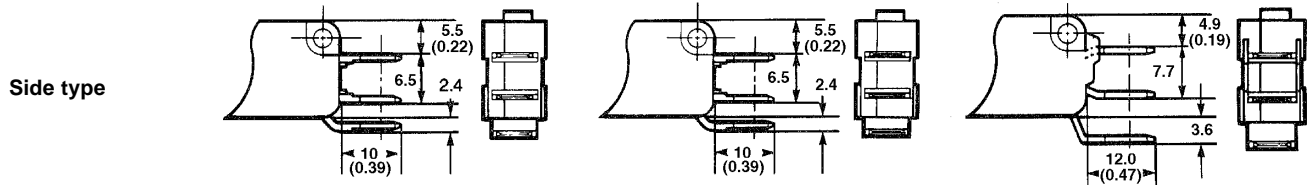
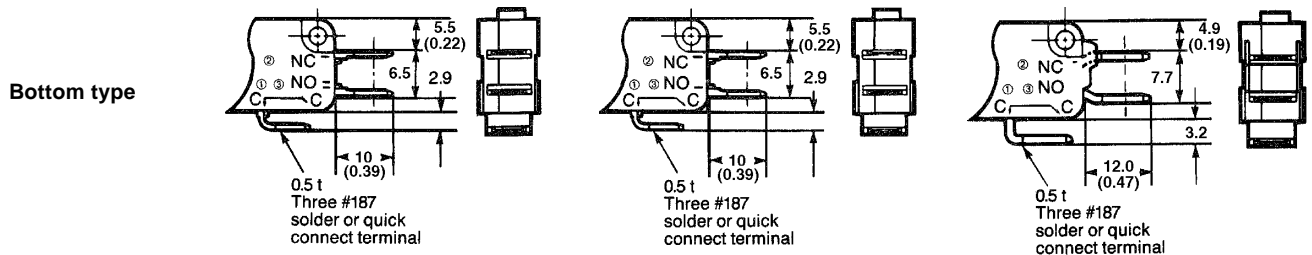
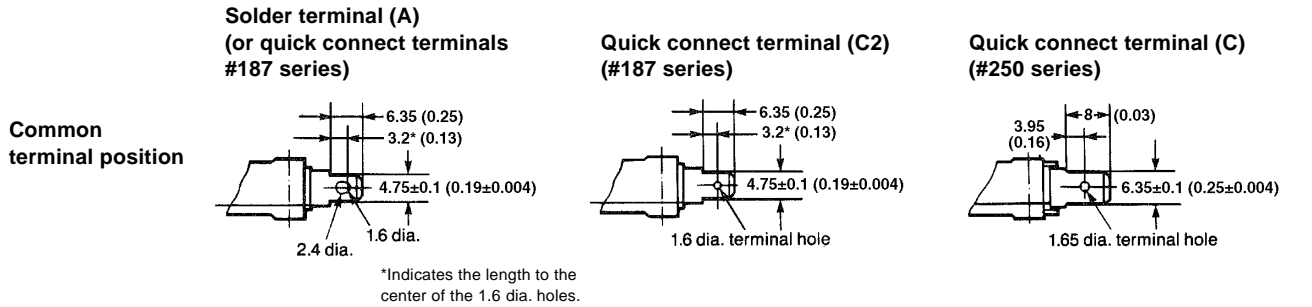

Common terminal position

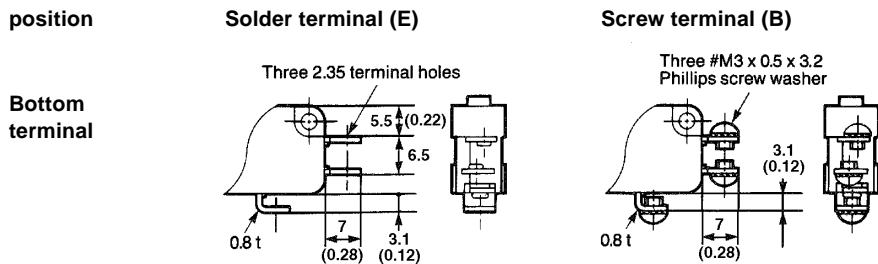



■ **ACCESSORIES** (order separately)

Unit: mm (inch)

Actuator accessories

Three series of actuators are optionally available: VAL, VAM, and VAV series.

The actuators in the VAL series are designated for rotary cam operations.

The VAM series actuators are highly resistive to vibration and shock; so, they are ideal for machine tools and automatic doors where the switches are subject to heavy vibration or shock.

The VAV series actuators are highly sensitive to force. Therefore, they should be used in an application where the operating force to be applied to the switch is critical.

All these actuators can be mounted on all OMRON basic switches having the following dimensions.

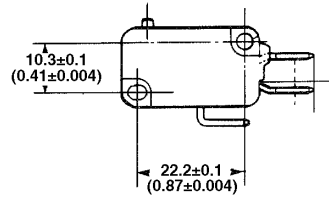

**Leaf spring type
VAL**

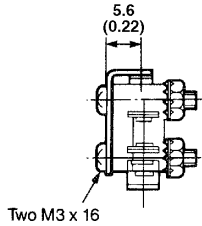
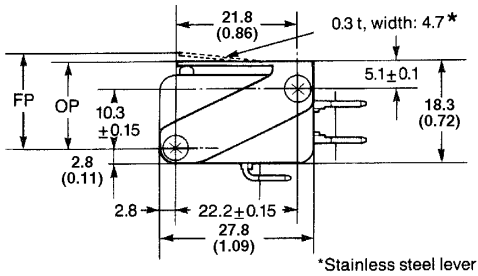

Operating characteristics	V-15G-1A5-K
OF max.	230 g
RF min.	50 g
OT min.	0.8 mm (0.03 in)
MD max.	0.4 mm (0.02 in)
FP max.	17 mm (0.67 in)
OP	14.9±0.5 mm (0.59±0.02 in)

**Roller leaf spring type
VAL2**

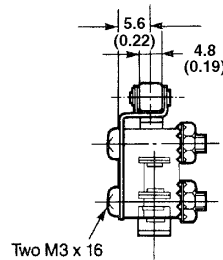
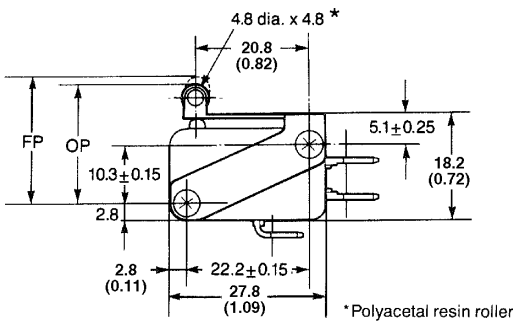

Operating characteristics	V-15G-1A5-K
OF max.	230 g
RF min.	50 g
OT min.	0.8 mm (0.03 in)
MD max.	0.4 mm (0.02 in)
FP max.	22.6 mm (0.89 in)
OP	20.5±0.5 mm (0.81±0.02 in)

- Note: 1. Unless otherwise specified, a tolerance of ± 0.4 mm applies to all dimensions.
 2. The operating characteristics above apply when the actuator is attached to V-15-1A5-K basic switch. For any other models, consult OMRON.



**Long hinge lever type
VAV**

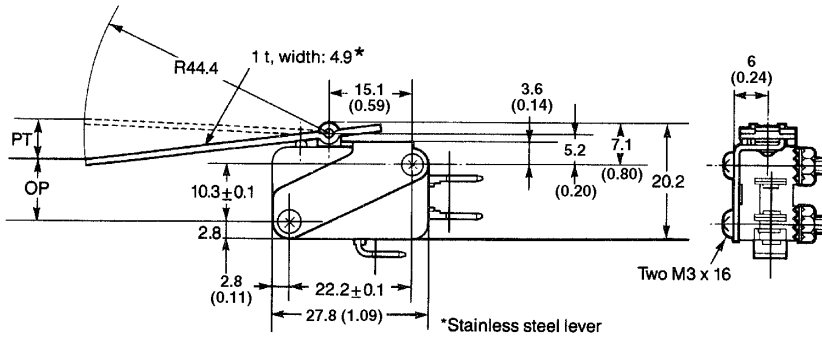

Operating characteristics	V-15G-1A5-K
OF max.	35 g
RF min.	4 g
OT min.	3.6 mm (0.14 in)
MD max.	4.7 mm (0.19 in)
OP	Approx. 10.6 mm (0.42 in)

**Hinge roller lever type
VAV 2**

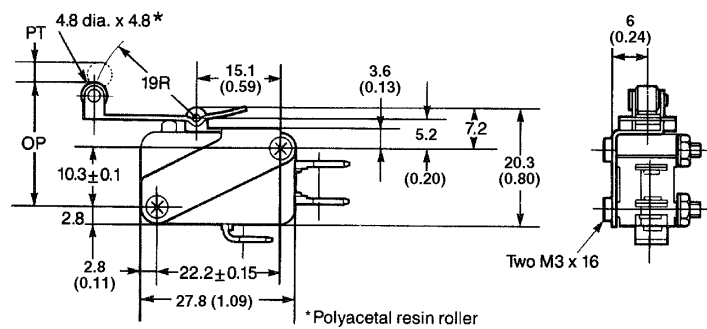

Operating characteristics	V-15G-1A5-K
OF max.	75 g
RF min.	9 g
OT min.	1.5 mm (0.06 in)
MD max.	1.2 mm (0.05 in)
OP	18.6±1.6 mm (0.73±0.06 in)

**Reverse-operation, long
hinge lever type
VAM**

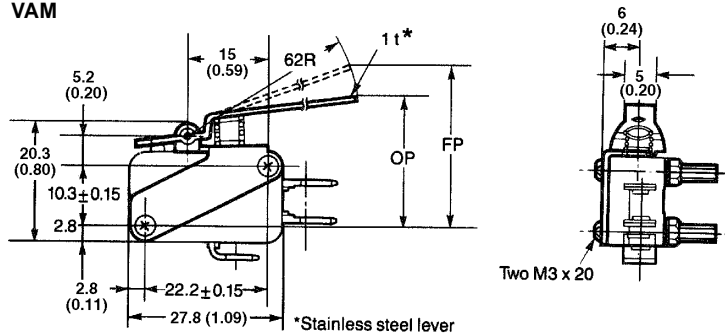

Operating characteristics	V-15G-1A5-K
OF max.	200 g
RF min.	30 g
OT min.	7 mm (0.28 in)
MD max.	7 mm (0.28 in)
FP max.	45 mm (1.78 in)
OP	20±9 mm (0.79±0.35 in)

Note: 1. Unless otherwise specified, a tolerance of ± 0.4 mm applies to all dimensions.



Unit: mm (inch)

■ **ACCESSORIES**, continued

Reverse-operation, simulated hinge lever type VAM-1

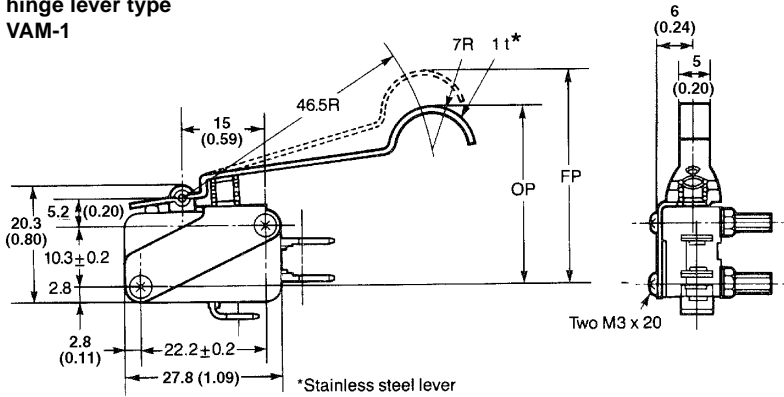

Operating characteristics	V-15G-1A5-K
OF max.	300 g
RF min.	40 g
OT min.	5 mm (0.20 in)
MD max.	6 mm (0.24 in)
FP max.	47 mm (1.85 in)
OP	30±5 mm (1.18±0.20 in)

Reverse-operation, simulated hinge lever type VAM-1

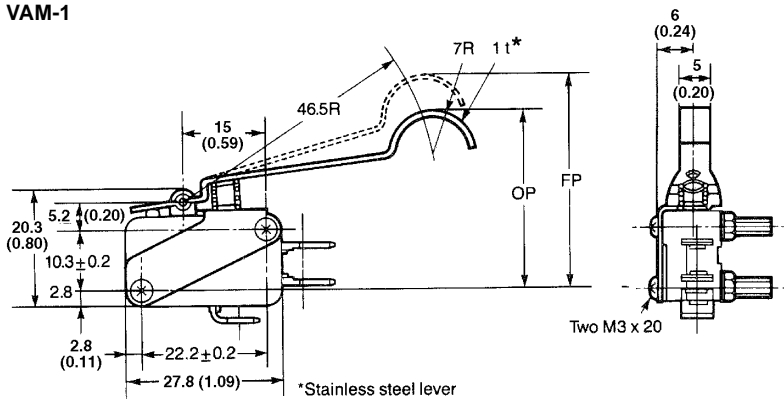

Operating characteristics	V-15G-1A5-K
OF max.	360 g
RF min.	70 g
OT min.	3 mm (0.12 in)
MD max.	4 mm (0.16 in)
FP max.	38 mm (1.50 in)
OP	31±3 mm (122±0.12 in)

Note: 1. Unless otherwise specified, a tolerance of ± 0.4 mm applies to all dimensions.

■ **APPROVALS**

UL (File No. E41515)/CSA (File No. LR21642)

	Thermoset material	
	V-15	V-10
OF max.		
100 g	UL CSA	UL CSA
200 g	UL CSA	UL CSA
400 g	UL CSA	— —

Note: 1. The rated values approved by each of the safety standards (e.g. UL, CSA) may be different from the performance characteristics individually defined in this catalog.
 2. Models approved by DEMKO, NEMKO, BEAB and SETI are also available. Consult OMRON for detailed information.



Precautions

■ MOUNTING

The switch is mounted with two M3 screws. When doing so, use an appropriate screwdriver and tighten the screws at a torque of 4 to 6 kg-cm.

To solder the lead to the terminal, apply a soldering iron rated at 60 W max. quickly (within 5 seconds) with the actuator at the free position.

Note that applying a soldering iron for too long a time or using one that is rated at more than 60 W may degrade the switch characteristics.

■ OPERATION

Make sure that the operating body pushes the switch actuator with an adequate force when the switch is to be operated, and that it does not touch the actuator when the switch is released.

Do not change the operating position by modifying the actuator.

Do not use the switch in an application where the operating speed is extremely slow or the actuator is set in the midpoint between the free position and operating position.

Install the pin plunger switch so that the operating force is applied in alignment with the stroke of the actuator. The switch should be set so that its stroke is in the range of 60 to 90% of the rated OT (minimum value) when the switch has been operated.

OMRON**OMRON ELECTRONICS, INC.**One East Commerce Drive
Schaumburg, IL 60173**1-800-55-OMRON****OMRON CANADA, INC.**885 Milner Avenue
Scarborough, Ontario M1B 5V8**416-286-6465**