

**RF Reed Relay Module
4 input / 2 output**

DESCRIPTION

The RM05-4AS-4/2 is a low-profile 4 input / 2 output Relay Module with an FR-4 substrate and rugged thermoset epoxy overmold. Capable of switching beyond 3 GHz with <40ps rise times, this Relay Module switches into the billions of operations. High temperature solder terminations allow BGA reflow temperatures up to 220°C.

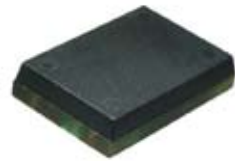

FEATURES

- FR-4/thermoset molded package
- Leadless SMT design eliminates skewing and coplanarity issues
- Minimum path length for RF
- <40ps rise times for switching fast pulses
- Standard with BGA
- Low profile
- Internal magnetic shielding
- Gold plated traces for high conductivity signal path
- Insulation resistance typically 10¹⁴ ohms

APPLICATIONS

- Test and Measurement
- Telecommunications
- High frequency applications

POST REFLOW HEIGHT

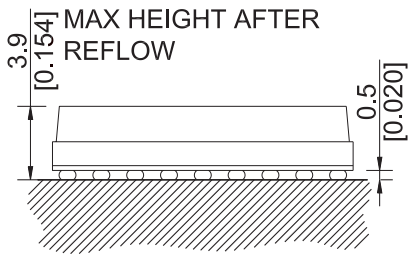

DIMENSIONS

All dimensions in mm [inches]
unspecified tolerances +/- 0.1 mm

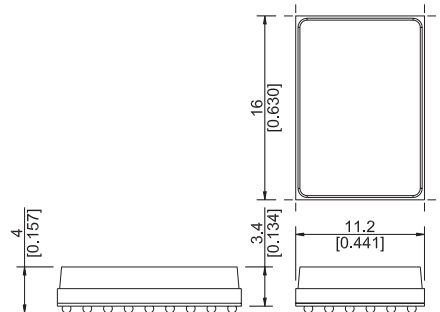

RF Reed Relay Module

4 input / 2 output

PAD LAYOUT (Top view)

GRID SPACING IS 1.8mm ON CENTER

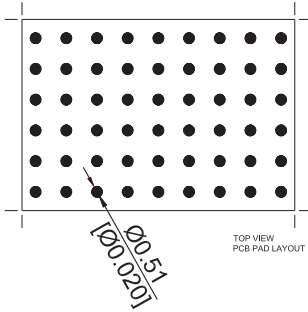

PAD DESIGNATION (Top view)

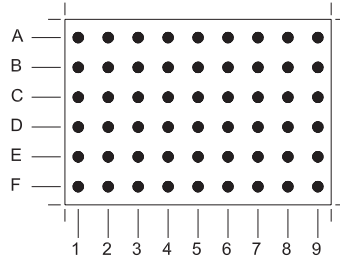

SHEMATIC (Top view)

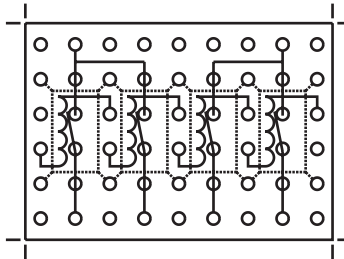

ORDER INFORMATION

Part Number Example

RM05 - 4AS - 4/2

- 05 is the nominal voltage
- 4A is the number and form of contacts
- S is the solder ball
- 4/2 is 4 input to 2 output

Series	Nominal Voltage	Contact form	Solder Balls	Input	Output
RM -	05 -	4A	S -	4/	2

COIL DATA

Contact Form	Switch Model	Coil Voltage		Coil Resistance			Pull-in Voltage	Drop-out Voltage	Nominal Coil Power
All Data at 20 °C *		VDC		Ω			VDC	VDC	mW
		Min.	Max.	Min.	Typ.	Max.	Max.	Min.	Typ.
4A	80			166.5	185	203.5	3.75	0.5	135
* The pull-in / drop-out voltage and coil resistance change at the rate of 0,4 % / °C.									

RELAY DATA

Module Characteristics		Min.	Typ	Max.	Units
Insertion Loss	Input / Output		TBD		dB
Voltage standing Wave Ratio VSWR	Input / Output		TBD		
Isolation	Input / Output		TBD		dB
Rise Time	Potential change Input / Output		TBD		psec
Characteristics Impedance	Input / Output		TBD		Ω

RF Reed Relay Module**4 input / 2 output****Relay Data**

All Data at 20° C	Switch Model → Contact form →	Switch 80 Form A / dry			
Contact Ratings	Conditions	Min.	Typ.	Max.	Units
Switching Power	Any combination of the switching voltage and the current must not exceed the given rated power.			10	W
Switching Voltage				125	V
Switching Current				1.0	A
Carry Current				1.5	A
Static Contact Resistance	Measured w/ nominal Voltage			100	mΩ
Insulation Resistance	RH Ω 45%	10 ¹⁰			Ω
Breakdown Voltage		200			VDC
Operation Time incl. Bounce	Measured w/ nominal Voltage		0.4		ms
Release Time	Without coil suppression		0.1		ms
Capacitance			0.3		pF
Life Expectancies					
Switching 5 Volts at 10 mA	DC only & < 10 pF stray capacitance			10 ⁸	Cycles
For other load requirements, see life test section.					
Environmental Data					
Insulation Resistance	Coil to Contact	10 ¹¹			Ω
Dielectric strength	Coil to Contact	1.5			kVDC
Shock Resistance	1/2 sine wave duration 11 ms			50	g
Vibration Resistance	10 - 2000 Hz			30	g
Ambient Temperature	10 °C/ minute max. allowable	-20		70	°C
Storage Temperature	10 °C/ minute max. allowable	-35		95	°C
Soldering Temperature	JEDEC Norm JESD22-A113A			260	°C
Cleaning		fully sealed			
Material of Case		FR4, Thermoset Molding Compound			
Material of Pins		Sn63/Pb37, 0.025" diameter			

RF Reed Relay Module
4 input / 4 output

DESCRIPTION

The RM05-4AS-4/4 is a low-profile 4 input / 4 output Relay Module with an FR-4 substrate and rugged thermose epoxy overmold. Capable of switching beyond 3 GHz with <40ps rise times, this Relay Module switches into the billions of operations. High temperature solder terminations allow BGA reflow temperatures up to 220°C.

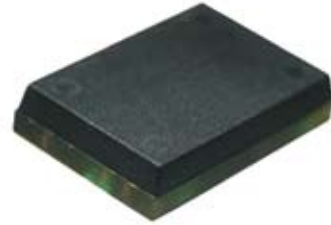

FEATURES

- FR-4/thermoset molded package
- Leadless SMT design eliminates skewing and coplanarity issues
- Minimum path length for RF
- <40ps rise times for switching fast pulses
- Standard with BGA
- Low profile
- Internal magnetic shielding
- Gold plated traces for high conductivity signal path
- Insulation resistance typically 10¹⁴ ohms

APPLICATIONS

- Test and Measurement
- Telecommunications
- High frequency applications

POST REFLOW HEIGHT

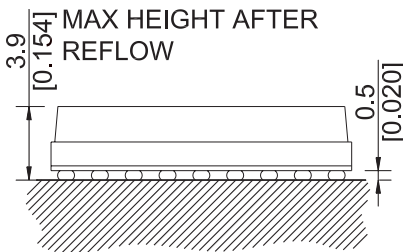

DIMENSIONS

All dimensions in mm [inches]
unspecified tolerances +/- 0.1 mm

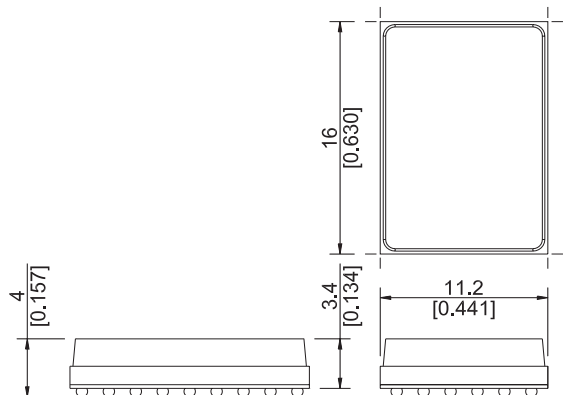

RF Reed Relay Module

4 input / 4 output

PAD LAYOUT (Top view)

PAD DESIGNATION (Top view)

GRID SPACING IS 1.8mm ON CENTER

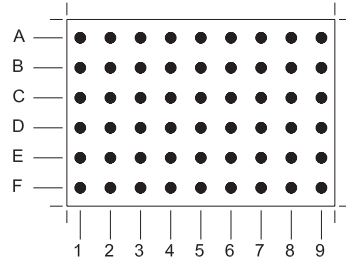
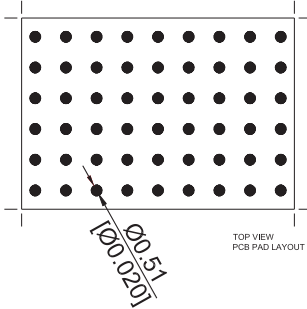

SHEMATIC (Top view)

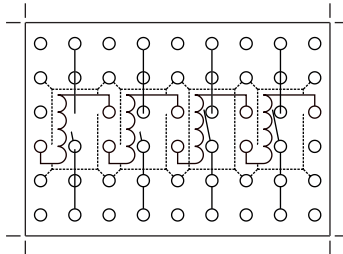

ORDER INFORMATION

Part Number Example

RM05 - 4AS - 4/4

05 is the nominal voltage

4A is the # and form of contacts

S is the solder ball

4/4 is 4 input to 4 output

Series	Nominal Voltage	Contact form	Solder Balls	Input	Output
RM -	05 -	4A	S -	4/	4

COIL DATA

Contact Form	Switch Model	Coil Voltage		Coil Resistance			Pull-in Voltage	Drop-out Voltage	Nominal Coil Power
All Data at 20 °C *		VDC		Ω			VDC	VDC	mW
		Min.	Max.	Min.	Typ.	Max.	Max.	Min.	Typ.
4A	80			166.5	185	203.5	3.75	0.5	135
* The pull-in / drop-out voltage and the coil resistance change at the rate of 0,4 % / °C.									

RELAY DATA

Module Characteristics		Min.	Typ	Max.	Units
Insertion Loss	Input / Output		TBD		dB
Voltage standing Wave Ratio VSWR	Input / Output		TBD		
Isolation	Input / Output		TBD		dB
Rise Time	Potential change Input / Output		TBD		psec
Characteristics Impedance	Input / Output		TBD		Ω

RF Reed Relay Module**4 input / 4 output****Relay Data**

All Data at 20° C	Switch Model → Contact form →	Switch 80 Form A / dry			
Contact Ratings	Conditions	Min.	Typ.	Max.	Units
Switching Power	Any combination of the switching voltage and the current must not exceed the given rated power.			10	W
Switching Voltage				170	V
Switching Current				0.5	A
Carry Current				0.5	A
Static Contact Resistance	Measured w/ nominal Voltage		200	250	mΩ
Insulation Resistance	RH Ω 45%	10 ¹⁰			Ω
Breakdown Voltage		210			VDC
Operation Time incl. Bounce	Measured w/ nominal Voltage		0.1		ms
Release Time	Without coil suppression		0.02		ms
Capacitance			0.1		pF
Life Expectancies					
Switching 5 Volts at 10 mA	DC only & < 10 pF stray capacitance		1000		10 ⁸ Cycles
For other load requirements, see life test section.					
Environmental Data					
Insulation Resistance	Coil to Contact	10 ¹¹			Ω
Dielectric strength	Coil to Contact	1.5			kVDC
Shock Resistance	1/2 sine wave duration 11 ms			50	g
Vibration Resistance	10 - 2000 Hz			10	g
Ambient Temperature	10 °C/ minute max. allowable	-40		85	°C
Storage Temperature	10 °C/ minute max. allowable	-55		125	°C
Soldering Temperature	JEDEC Norm JESD22-A113A	190		260	°C
Cleaning		fully sealed			
Material of Case		FR4, Thermoset Molding Compound			
Material of Pins		Sn63/Pb37, 0.025" diameter			

**RF Reed Relay Module
4 input / 1 output**

DESCRIPTION

The RM05-6AS-4/1 is a low-profile 4 input / 1 output Relay Module with an FR-4 substrate and rugged thermoset epoxy overmold. Capable of switching beyond 3 GHz with <40ps rise times, this Relay Module switches into the billions of operations. High temperature solder terminations allow BGA reflow temperatures up to 220°C.



FEATURES

- FR-4/thermoset molded package
- Leadless SMT design eliminates skewing and coplanarity issues
- Minimum path length for RF
- <40ps rise times for switching fast pulses
- Standard with BGA
- Low profile
- Internal magnetic shielding
- Gold plated traces for high conductivity signal path
- Insulation resistance typically 10¹⁴ ohms

APPLICATIONS

- Test and Measurement
- Telecommunications
- High frequency applications

DIMENSIONS

All dimensions in mm [inches]
unspecified tolerances +/- 0.1 mm

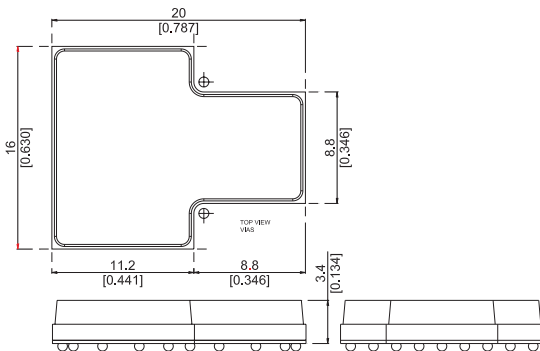

POST REFLOW HEIGHT

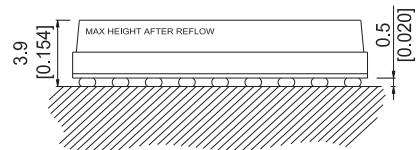

RF Reed Relay Module

4 input / 1 output

PAD LAYOUT (Top view)

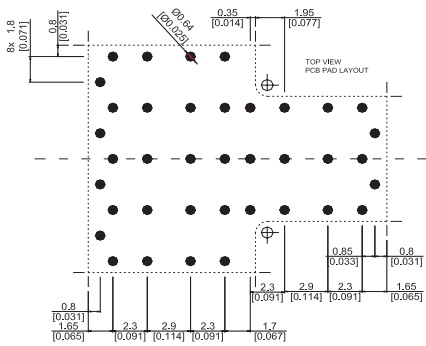

PAD DESIGNATION (Top view)

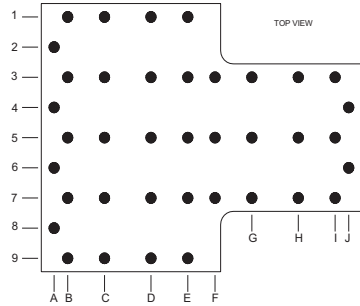

SHEMATIC (Top view)

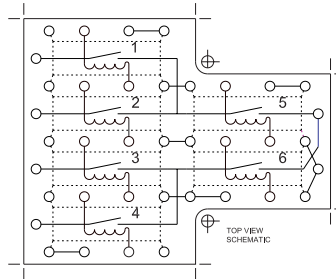

ORDER INFORMATION

Part Number Example

RM05 - 6AS - 4/1

- 05 is the nominal voltage
- 6A is the # and form of contacts
- S is the solder ball
- 4/1 is 4 input to 1 output

Series	Nominal Voltage	Contact form	Solder Balls	Input	Output
RM -	05 -	6A	S -	4/	1

COIL DATA

Contact Form	Switch Model	Coil Voltage		Coil Resistance			Pull-in Voltage	Drop-out Voltage	Nominal Coil Power
All Data at 20 °C *		VDC		Ω			VDC	VDC	mW
		Min.	Max.	Min.	Typ.	Max.	Max.	Min.	Typ.
6A	80			166.5	185	203.5	3.75	0.5	135
* The pull-in / drop-out voltage and the coil resistance change at the rate of 0,4 % / °C.									

RELAY DATA

Module Characteristics		Min.	Typ	Max.	Units
Insertion Loss	Input / Output		TBD		dB
Voltage standing Wave Ratio VSWR	Input / Output		TBD		
Isolation	Input / Output		TBD		dB
Rise Time	Potential change Input / Output		TBD		psec
Characteristics Impedance	Input / Output		TBD		Ω

RF Reed Relay Module**4 input / 1 output****RELAY DATA**

All Data at 20° C	Switch Model → Contact form →	Switch 80 Form A / dry			
Contact Ratings	Conditions	Min.	Typ.	Max.	Units
Switching Power	Any combination of the switching voltage and the current must not exceed the given rated power.			10	W
Switching Voltage	DC or Peak AC			170	VDC
Switching Current	DC or Peak AC			0.5	A
Carry Current	DC or Peak AC			0.5	A
Static Contact Resistance	Measured w/ nominal Voltage		200	250	mΩ
Insulation Resistance	RH Ω 45%	10 ¹⁰ 10 ¹²			Ω
Breakdown Voltage		210 1500			VDC
Operation Time incl. Bounce	Measured w/ nominal Voltage		0.1		ms
Release Time	Without coil suppression		0.02		ms
Capacitance			0.1		pF
Life Expectancies					
Switching 5 Volts at 10 mA	DC only & < 10 pF stray capacitance		1000		10 ⁸ Cycles
For other load requirements, see life test section.					
Environmental Data					
Insulation Resistance	Coil to Contact	10 ¹¹			Ω
Dielectric strength	Coil to Contact	1.5			kVDC
Shock Resistance	1/2 sine wave duration 11 ms			50	g
Vibration Resistance	10 - 2000 Hz			10	g
Ambient Temperature	10 oC/ minute max. allowable	-40		85	°C
Storage Temperature	10 oC/ minute max. allowable	-55		125	°C
Soldering Temperature	JEDEC Norm JESD22-A113A	190		260	°C
Cleaning		fully sealed			
Material of Case		FR4, Thermoset Molding Compound			
Material of Pins		Sn63/Pb37, 0.025" diameter			

DESCRIPTION

The RM05-8A is a complete Relay Module with one serial digital 8 bit input channel, to drive a double output matrix with 4 to 1 channel each. Insert the code for the out signals at serial Input 8. At each positive impulse (clock signal) at Input 4, the code will be proceeded and the already inserted code in the shift register shifted forward one step. At pin 2, the code (9 clock signals shifted) can be transferred to the next module to drive even more Relay Modules. Is programming finished, the code in the shift register can be transferred to the output drives with a positive impulse (clock signal) at Input 5, witch will activate the selected output switches.



FEATURES

- Reed Relay Module with integrated shift register, storage register and buffer
- Saves PCB space
- Saves wiring costs
- Saves assembly costs

APPLICATIONS

- Test and Measurement
- Telecommunications

DIMENSIONS

All dimensions in mm [inches]
 unspecified tolerances +/- 0.1 mm

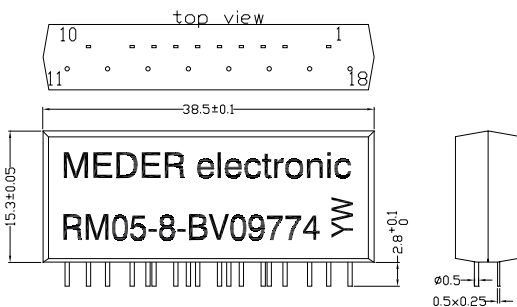

PAD LAYOUT

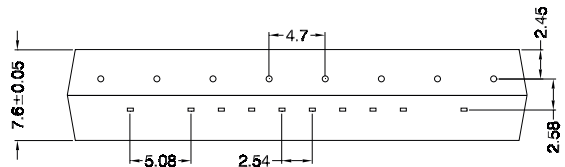

Reed Relay Module RM05-8A

SHEMATIC

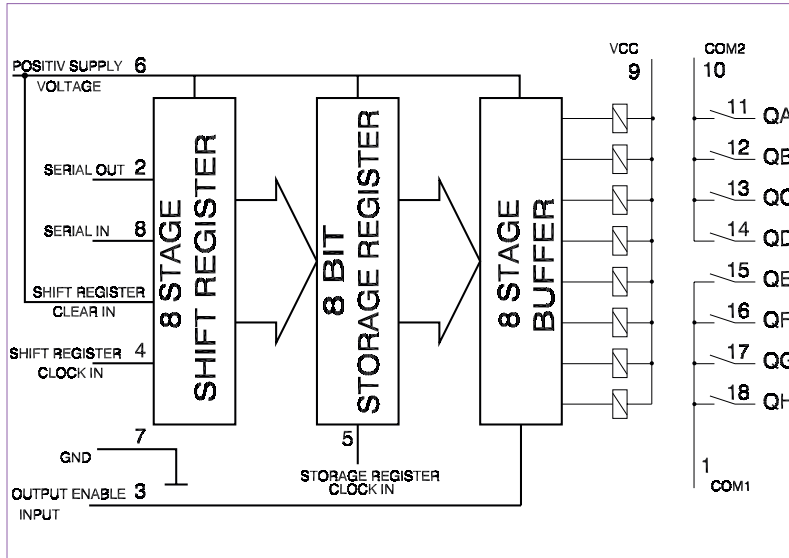

RELAY MODULE COIL DATA

Coil / Relay Characteristics	Condition at 20 °C	Min.	Typ	Max.	Units
Current consumption with each switched contact	at 5V operating voltage	9	10	11	mA
Nominal Voltage		4.75	5.0	5.25	VDC
Nominal power with each switched contact	at 5V operating voltage		50		mW
Insulation Resistance Coil to Contact		10 ¹¹			Ω
Dielectric Strength Coil to Contact		1.5			kVDC

RELAY DATA

All Data at 20° C	Switch Model → Contact form →	Switch 80 Form A / dry			
Contact Ratings	Conditions	Min.	Typ.	Max.	Units
Switching Power	Any combination of the switching voltage and the current must not exceed the given rated power.			10	W
Switching Voltage	DC or Peak AC			125	VDC
Switching Current	DC or Peak AC			1.0	A
Carry Current	DC or Peak AC			1.5	A
Static Contact Resistance	Measured w/ nominal Voltage			100	mΩ
Insulation Resistance	RH Ω 45%	10 ¹⁰			Ω
Breakdown Voltage		200			VDC
Operation Time incl. Bounce	Measured w/ nominal Voltage		0.4		ms
Release Time	Without coil suppression		0.1		ms
Capacitance			0.3		pF
Life Expectancies					
Switching 5 Volts at 10 mA	DC only & < 10 pF stray capacitance		1000		10 ⁸ Cycles
For other load requirements, see life test section.					
Environmental Data		10 ¹¹			
Insulation Resistance	Coil to Contact	1.5			Ω
Dielectric strength	Coil to Contact			50	kVDC
Shock Resistance	1/2 sine wave duration 11 ms			30	g
Vibration Resistance	10 - 2000 Hz	-20		70	g
Ambient Temperature	10 °C/ minute max. allowable	-35		95	°C
Storage Temperature	10 °C/ minute max. allowable			260	°C
Soldering Temperature	JEDEC Norm JESD22-A113A	190		260	°C
Cleaning		fully sealed			
Material of Case		FR4, Thermoset Molding Compound			
Material of Pins		Sn63/Pb37, 0.65mm diameter			