

## CS1060 Reaction Torque Sensor



- **Square male coupling**
- **±5 to ±7,000 Nm (±4 to ±5,600 Lbf-ft)**
- **Stainless Steel**
- **Cable Gland or Connector Output**
- **Built In Amplifier per Request**

### DESCRIPTION

The CS1060 has been designed to measure reaction torque. Its sensing element is based on thin layer strain gauges in a Wheatstone bridge configuration providing excellent temperature stability. Optionally the torque sensor can receive an on-board amplifier for high level output. Intermediate ranges are available at no extra cost.

With many years of experience as a designer and manufacturer of sensors, Measurement Specialties often works with customers to design or customize sensors for specific uses and testing environments.

To meet your needs we also offer complete turnkey systems. The matched components (sensor, power, amplifier and digital display) are formatted, calibrated and ready for immediate use.

### FEATURES

- Ranges from ±5 Nm to ±7000 Nm (±4 lbf-ft to ±5600 Lbf-ft)
- Suited for static applications
- Square male coupling
- High Level Output Model with Integrated Amplifier

### APPLICATIONS

- Non-Rotating parts torque measurement
- Test and Measurement
- Robotics and effectors
- Laboratory and Research

### STANDARD RANGES

F.S. Ranges in Nm	5 to 100	101 to 300	301 to 800	801 to 3K	3001 to 7K
F.S. Ranges in Lbf-ft	40 to 80	81 to 240	241 to 640	641 to 2,4K	2401 to 5,6K
Stiffness in Nm/rad	$2 \times 10^2$ to $1 \times 10^4$	$1 \times 10^4$ to $4 \times 10^4$	$4 \times 10^4$ to $1.2 \times 10^5$	$1.2 \times 10^5$ to $6 \times 10^5$	$6 \times 10^5$ to $1.8 \times 10^6$
Stiffness in Lbf-ft/rad	$1.4 \times 10^1$ to $6.9 \times 10^2$	$6.9 \times 10^2$ to $2.7 \times 10^3$	$2.7 \times 10^3$ to $8.2 \times 10^3$	$8.2 \times 10^3$ to $4.1 \times 10^4$	$4.1 \times 10^4$ to $1.2 \times 10^5$

## CS1060 Reaction Torque Sensor

### PERFORMANCE SPECIFICATIONS

**Ambient Temperature: 20±1°C (unless otherwise specified)**

#### PARAMETERS

Operating Temperature Range (OTR)	-20 to 80°C (-4 to 176°F)
Compensated Temperature Range (CTR)	0 to 60°C (32 to 140°F)
Zero Shift in CTR	<0.5% F.S./50°C (100°F)
Sensitivity Shift in CTR	<2.10 <sup>-4</sup> /°C of reading [ $<1.10^{-4}$ / °F of reading]
Range (F.S.)	±5 Nm to ±7 kNm [±4 lbf-ft to ±5.6 klf-ft]
<b>Over-Range</b>	
Without Damage	1.5 x F.S.
<b>Accuracy</b>	
Combined Non-Linearity & Hysteresis	±0.25%F.S.

#### Electrical Characteristics

Model	CS1060	CS1060-A1	CS1060-A2
Supply Outage	10Vdc	10 – 30Vdc	±15Vdc (±12 to ±18Vdc)
F.S. Output	2mV/V	0.5 to 4.5Vdc	±5V
Zero Offset	<±5% F.S.	2.5V ±5% F.S.	0V ±5% F.S.
Input Impedance/Consumption	350 to 700Ω	<50mA	<30mA
Output Impedance	350 to 700Ω	<10Ω	<10Ω
Insulation under 50Vdc	≥100MΩ	≥100MΩ	≥100MΩ

#### Notes

1. Electrical Termination: Connector output including mate
2. Material: Body in stainless steel and housing in aluminum alloy
3. Connection : Square male couplings standard depending on F.S. ; other connection types on request (smooth shaft, cotter pin, etc)

# CS1060 Reaction Torque Sensor

## DIMENSIONS & WIRING SCHEMATIC (IN METRIC AND IMPERIAL)

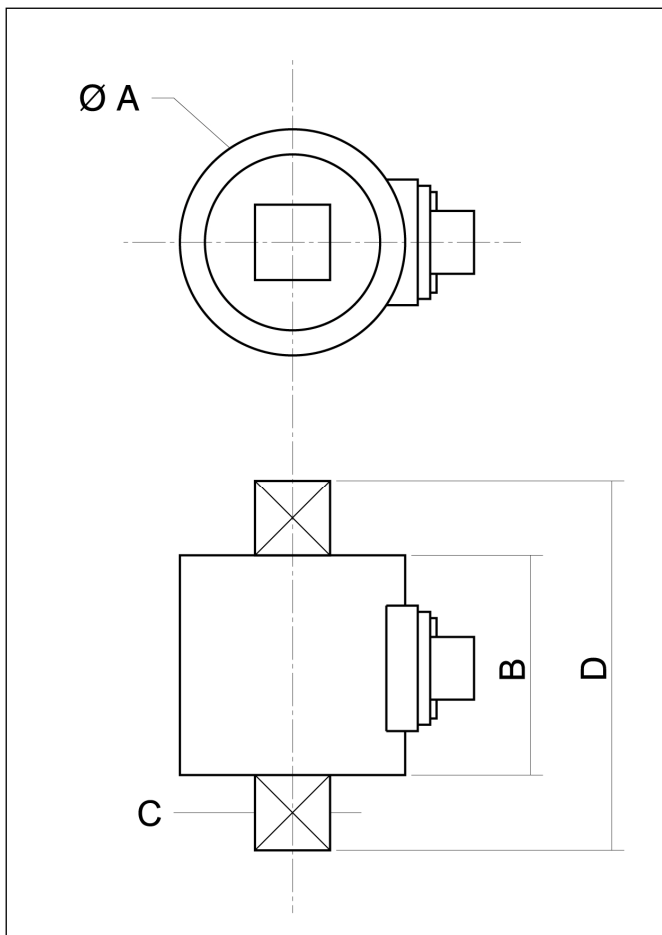

### Wiring Schematic

#### CS1060

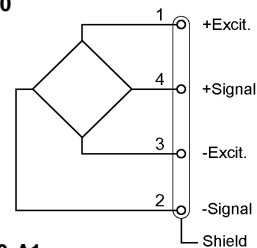

#### CS1060-A1

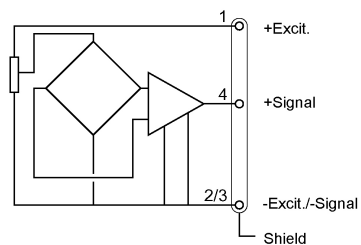

#### CS1060-A2

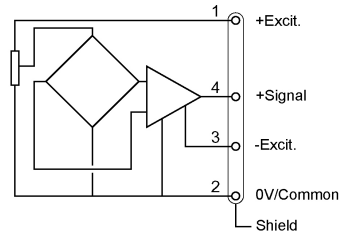

### Mechanical Dimensions in mm [inch]

F.S. in N.m [Lbf-ft]	5 to 100 [4 to 80]	101 to 300 [81 to 240]	301 to 800 [241 to 640]	801 to 3000 [641 to 2400]	3001 to 7000 [2401 to 5600]
A	35 [1.38]	40 [1.57]	50 [1.97]	65 [2.56]	85 [3.35]
B	35 [1.38]	40 [1.57]	45 [1.77]	55 [2.17]	60 [2.36]
C	12.7 [1/2"]	19 [3/4"]	25.4 [1"]	38.1 [1"1/2]	50.8 [2"]
D	59 [2.32]	80 [3.15]	95 [3.74]	135 [5.31]	160 [6.30]

## CS1060 Reaction Torque Sensor

### OPTIONS

<b>A1</b> : Unipolar Tension
<b>A2</b> : Bipolar Tension (ex.±15Vdc)
<b>ET1</b> : CTR -20 to 100 °C [-4 to 212 °F] OTR=CTR
<b>PE</b> : Cable Gland Termination with 2 m [6.6 ft] cable

### ORDERING INFO

CS1060 - A1 - 7KNm - /ET1/PE

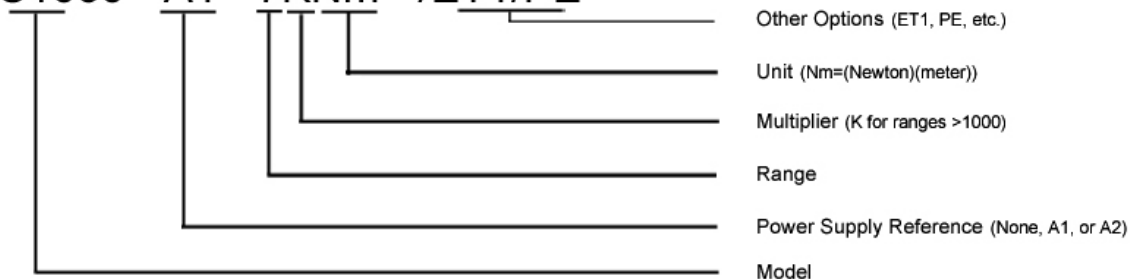

The information in this sheet has been carefully reviewed and is believed to be accurate; however, no responsibility is assumed for inaccuracies. Furthermore, this information does not convey to the purchaser of such devices any license under the patent rights to the manufacturer. Measurement Specialties, Inc. reserves the right to make changes without further notice to any product herein. Measurement Specialties, Inc. makes no warranty, representation or guarantee regarding the suitability of its product for any particular purpose, nor does Measurement Specialties, Inc. assume any liability arising out of the application or use of any product or circuit and specifically disclaims any and all liability, including without limitation consequential or incidental damages. Typical parameters can and do vary in different applications. All operating parameters must be validated for each customer application by customer's technical experts. Measurement Specialties, Inc. does not convey any license under its patent rights nor the rights of others.