



# Steady State IR Emitters

## STEADY-STATE (DC) SOURCE-SHA Series

Cal Source SHA-Series infrared (IR) emitters are designed to be used as Steady State (DC) emitters of blackbody radiation.

The radiating element in the Steady State emitters is a coiled filament of a Cal Sensors specific material with a specialized coating to give an emissivity of 0.70. Radiated output closely emulates a blackbody in spectral distribution. SHA-Series emitters are designed to operate at a rated filament temperature of 1170° K.

SHA-Series emitters are offered in TO-5 packages with specific filament diameters and number of coils to provide the desired input/output power at a filament temperature of 1170° K.

The new emitters include a parabolic reflector to provide near collimated and uniform radiation output. These packages do not include windows.

### Drive Circuit

Any constant voltage or constant current DC power supply with appropriate rating.

### Lifetime

The mean time before failure (MTBF) is greater than 30,000 hours at the maximum rated power input. Operation of the element above this input power may significantly reduce the lifetime.

### Filament Temperature vs. Input Power

Steady State emitters are designed to operate with a filament temperature of approximately 1170° K (900°C) at the rated input power. Exceeding this value will raise element temperature and decrease emitter lifetime. Since the radiated energy is proportional to the fourth power of the absolute temperature ( $T^4$ ) accurate control of the input power and proper heat sinking of the package are essential to maintain constant element temperature and output. The relationship between peak wavelength ( $\lambda_{pk}$  in microns) and temperature ( $T$  in ° Kelvin) for the blackbody spectrum is expressed by Wien's law as,

$$\lambda_{pk} \text{ (microns)} \times T \text{ (}^\circ\text{K)} = 2898$$

Thus, the wavelength for maximum excittance varies inversely with the absolute temperature. At a temperature of 1170° K, this maximum is at 2.5 microns. Like the standard emitters, the High Output Cal Source Steady State emitters are quasi-blackbody with an emissivity of 0.70. The emissivity is the ratio of the energy radiated by the source to that which would be radiated by a true blackbody at the same temperature.

SUNSTAR传感与控制 <http://www.sensor-ic.com/> TEL: 0755-83376549 FAX: 0755-83376182 E-MAIL: szss20@163.com

# (SHA) Steady State Emitters in a TO-5 Package

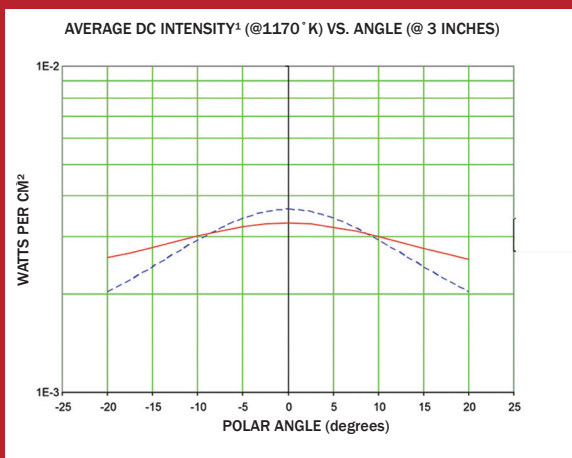
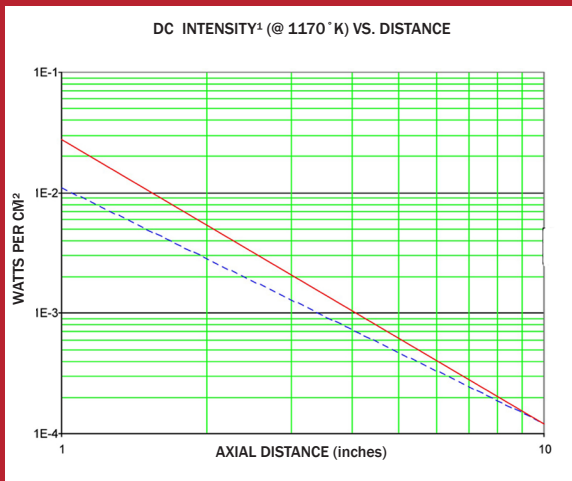

¹ Average of values parallel and perpendicular to axis of element

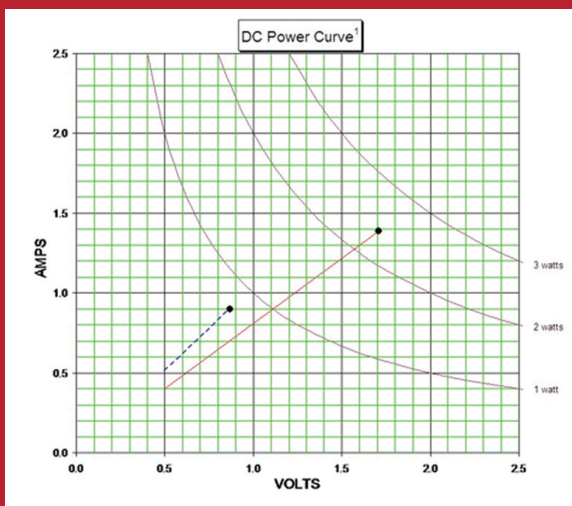

¹ 1170° at power indicated ( ). Exceeding this value will raise element temperature and decrease source lifetime.

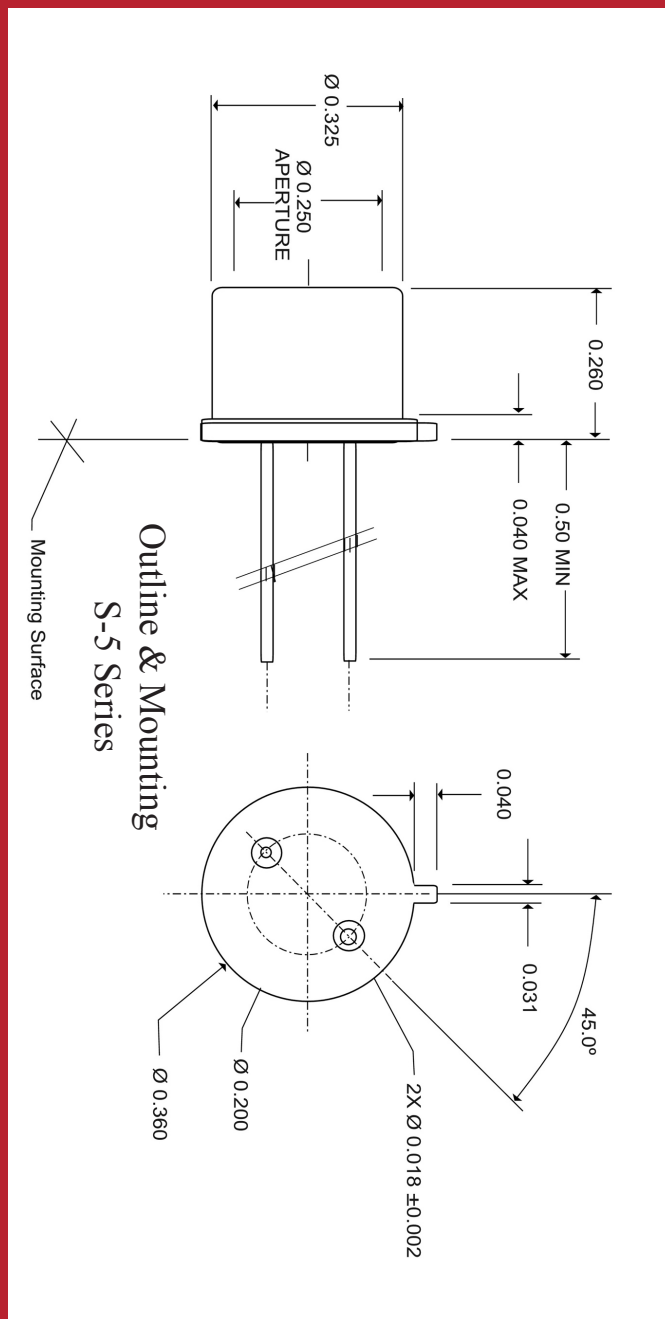

--- Average SHA727 @ 0.79 Watts Input Power  
— Average SHA1037 @ 2.38 Watts Input Power