

# UV 10.SF - Ultraviolet Detector

## High Sensitivity

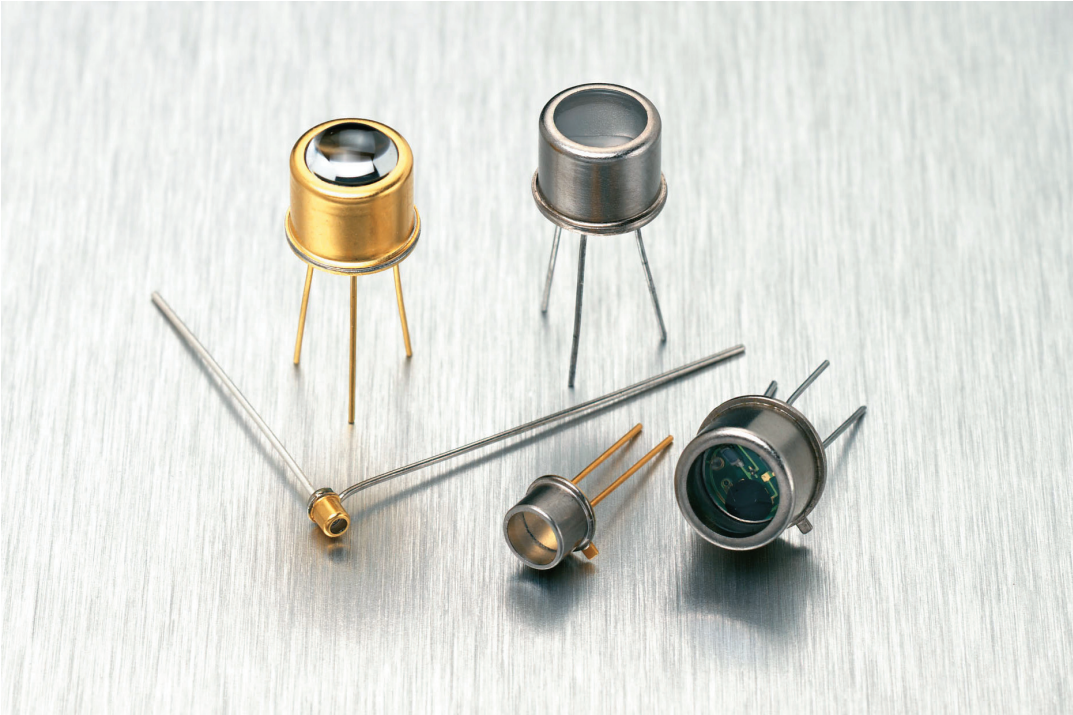

### Description

**UV 10.SF** is made in **TO-5 housing**. It includes the sensitive diode and the standard transmissive window. Optionally, as shown on page 2, filter window types are available.

PerkinElmer Optoelectronics offers a range of selective sensors for ultraviolet radiation. This sensor series can be equipped with an integrated amplifier and is perfectly suited for the detection of any radiation ranging from 200 nm to 400 nm. High sensitivity, hermetic encapsulation, small dimension (TO-5) and low-cost structure provide suitability for both industrial and consumer applications.

UV detectors from PerkinElmer Optoelectronics are based on silicon-carbide, a material that offers new performance features at reasonable costs. Silicon-carbide provides a unique sensitivity in the spectral range from 200 nm to 400 nm (peak at 280 nm).

### Applications

- Industrial Controls
- Sterilization
- Commodity Applications
- Solar Measurements

### Features

- High Sensitivity
- Solar Blind
- Low Temperature Dependence
- Hermetic Package



**Figure 1. Timing Diagram**

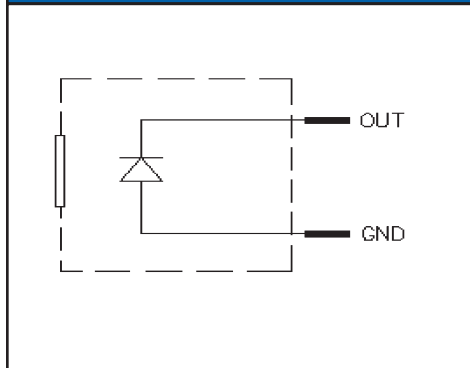

**Figure 4. Package Dimensions**

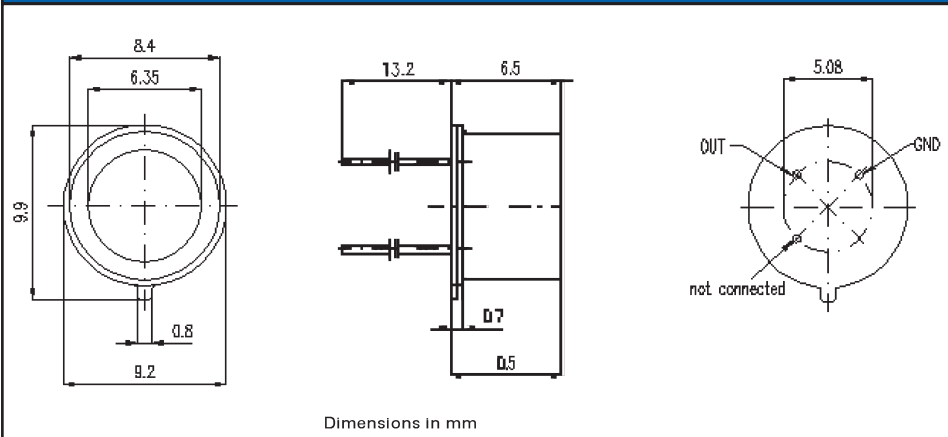

**Figure 2. Spectral Curve**

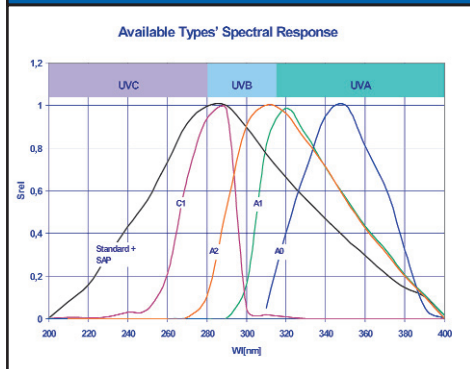

**Table 1. UV 10.SF Specifications**

Parameters	Typical	Units	Condition
Radiant sensitivity	140	mA/W	standard window
Spectral response	210-380	nm	5% of peak
Wavelength of pk response	280	nm	
Sensitive area	$5.4 \times 10^{-2}$	mm <sup>2</sup>	active diode area
Selectivity	$>10^{-5}$		400...2000 nm
Dark current	0.2	fA	
Junction capacitance	21	pF	
Temperature coefficient	-0.5	%/K	
Storage temperature	-20 to 80	°C	non permanent
Operating temperature	-20 to 80	°C	non permanent
Window transparency	$>210$	nm	

**Figure 3.**

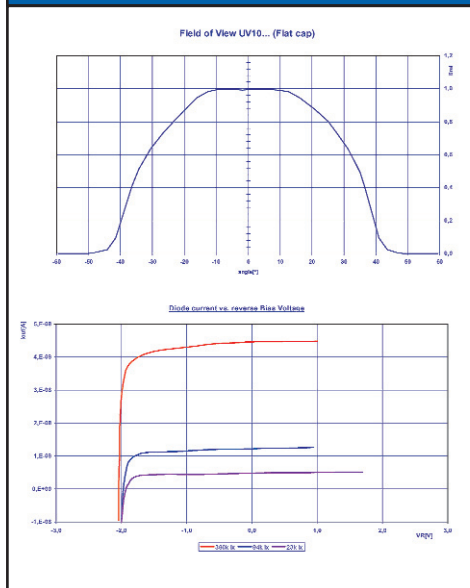

For more information e-mail us at [opto@perkinelmer.com](mailto:opto@perkinelmer.com) or visit our website at [www.perkinelmer.com/optoelectronics](http://www.perkinelmer.com/optoelectronics)  
 All values are nominal; specifications subject to change without notice.

North America:  
 PerkinElmer Optoelectronics  
 16800 Trans-Canada Highway  
 Kirkland, Quebec J7V 8P7 Canada  
 Toll Free: (877) 734-OPTO (6786)  
 Phone: +1-450-424-3300  
 Fax: +1-450-424-3411

Europe:  
 PerkinElmer Optoelectronics  
 Wenzel-Jaksch-Str. 31  
 D-65199 Wiesbaden, Germany  
 Phone: +49-611-492-430  
 Fax: +49-611-492-165

Asia:  
 PerkinElmer Optoelectronics  
 47 Ayer Rajah Crescent #06-12  
 Singapore 139947  
 Phone: +65-6770-4366  
 Fax: +65-6775-1008

