



STLM20

Ultra-low current 2.4V precision analog temperature sensor

Features

- Precision analog voltage output temperature sensor
- $\pm 1.5^{\circ}\text{C}$ temperature accuracy at 25°C
- Ultra-low quiescent supply current: $8.0\mu\text{A}$ (max)
- Operating voltage range: 2.4V to 5.5V
- Operating temperature range:
 - 55°C to 130°C (grade - 7)
 - 40°C to 85°C (grade - 9)
- SOT323-5 (SC70-5) 5-lead package
- UDFN 4-lead package

Applications

- Third generation (3G) cell phones
- Multimedia PDA devices
- GPS devices
- Portable medical instruments
- Voltage-controlled crystal oscillator temperature monitors
- RF Power transistor monitor

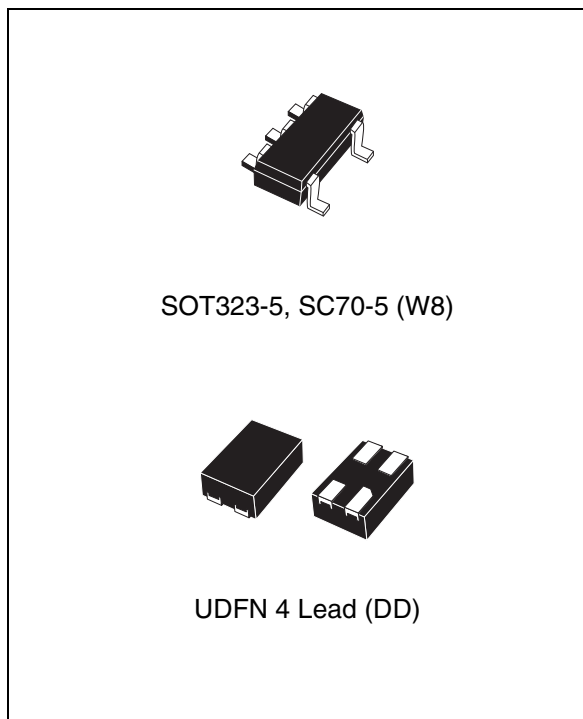

Contents

1	Summary description	5
2	Transfer function	7
3	Maximum rating	9
4	DC and AC characteristics	10
5	Capacitive load	11
6	Typical operating characteristics	12
7	Package mechanical	13
8	Part numbering	15
9	Revision history	16

List of tables

Table 1.	Signal names	5
Table 2.	First order equations optimized for different temperature ranges.	7
Table 3.	Quadratic output equation ($V_{CC} = 2.7V$)	8
Table 4.	Quadratic output equation for operations over the full voltage range ($V_{CC} = 2.4V$ to $5.5V$)	8
Table 5.	Absolute maximum ratings	9
Table 6.	DC and AC characteristics	10
Table 7.	Resistor/capacitor combinations for the filter network	11
Table 8.	SOT323-5 – 5-lead small outline transistor package mechanical data.	13
Table 9.	UDFN - 4 lead mechanical data	14
Table 10.	Ordering information scheme	15
Table 11.	Marking description.	15
Table 12.	Revision history	16

List of figures

Figure 1.	Logic diagram	5
Figure 2.	Connections (top view)	6
Figure 3.	Filter network for noisy environments or capacitive loads > 300pF	11
Figure 4.	V _{OUT} vs. Temperature	12
Figure 5.	SOT323-5 – 5-lead small outline transistor package outline	13
Figure 6.	UDFN – 4-lead package outline	14

1 Summary description

The STLM20 is a precision analog output temperature sensor for low current applications where maximizing battery life is important. It operates over a -55°C to 130°C (grade 7) or -40°C to 85°C (grade 9) temperature range. The power supply operating range is 2.4V to 5.5V. The accuracy of the STLM20 is $\pm 1.5^{\circ}\text{C}$, at an ambient temperature of 25°C . The temperature error increases linearly and reaches a maximum of $\pm 2.5^{\circ}\text{C}$ at the temperature range extremes. The temperature range is affected by the power supply voltage. For the temperature grade 7 device, a power supply voltage of 2.7V to 5.5V, the temperature range extremes are $+130^{\circ}\text{C}$ and -55°C . Decreasing the power supply voltage to 2.4V changes the negative extreme to -30°C , while the positive remains at $+130^{\circ}\text{C}$.

The STLM20 has a maximum quiescent supply current of $8\mu\text{A}$. Therefore, self-heating is negligible.

Figure 1. Logic diagram

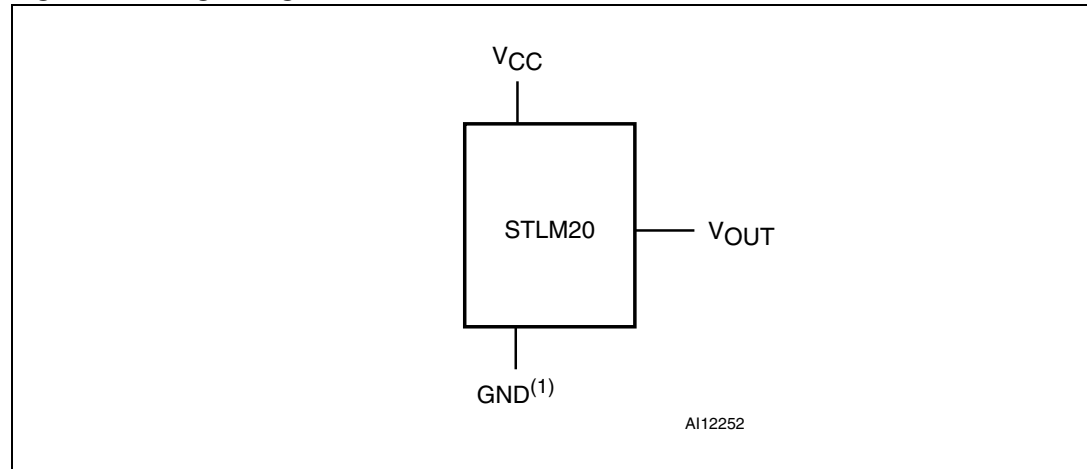

1. Pin 2 GND may be grounded or left floating (SC70-5 only). For optimum thermal conductivity to the PC board ground plane, it should be grounded.

Table 1. Signal names

V_{CC}	Supply voltage
GND	Ground
V_{OUT}	Output voltage
NC	No connect

Figure 2. Connections (top view)

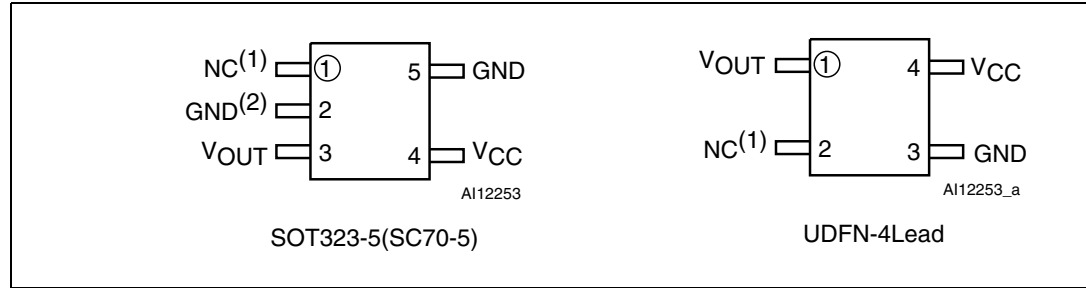

1. Pin 1 NC should be left floating or grounded.
2. Pin 2 GND may be grounded or left floating. For optimum thermal conductivity to the PC board ground plane, it should be grounded.

2 Transfer function

The STLM20's transfer function can be described in different ways, with varying levels of precision. A simple linear transfer function, with good accuracy near 25°C is expressed as:

Equation 1

$$V_O = (-11.69\text{mV}/^\circ\text{C}) \times T + 1.8663\text{V}$$

Over the specified operating temperature range, the best accuracy can be obtained by using the parabolic transfer function:

Equation 2

$$V_O = (-3.88 \times 10^{-6} \times T^2) + (-1.15 \times 10^{-2} \times T) + 1.8639$$

and solving for T:

Equation 3

$$T = -1481.96 + \sqrt{2.1962 \times 10^6 + \frac{(1.8639 - V_O)}{3.88 \times 10^{-6}}}$$

The best fit linear transfer function for many popular temperature ranges was calculated in [Table 2](#), where the error introduced by the linear transfer function increases with wider temperature ranges.

Table 2. First order equations optimized for different temperature ranges

Temperature range		Linear equation $V_O =$	Maximum deviation of linear equation from parabolic equation (°C)
T_{\min} (°C)	T_{\max} (°C)		
-55	130	$-11.79\text{mV}/^\circ\text{C} * T + 1.8528\text{V}$	±1.41
-40	110	$-11.77\text{mV}/^\circ\text{C} * T + 1.8577\text{V}$	±0.93
-30	100	$-11.77\text{mV}/^\circ\text{C} * T + 1.8605\text{V}$	±0.70
-40	85	$-11.67\text{mV}/^\circ\text{C} * T + 1.8583\text{V}$	±0.65
-10	65	$-11.71\text{mV}/^\circ\text{C} * T + 1.8641\text{V}$	±0.23
35	45	$-11.81\text{mV}/^\circ\text{C} * T + 1.8701\text{V}$	±0.004
20	30	$-11.69\text{mV}/^\circ\text{C} * T + 1.8663\text{V}$	±0.004

Table 3. Quadratic output equation ($V_{CC} = 2.7V$)

Parameter	Conditions	Min	Typ	Max	Unit
Temperature error based on: $V_{OUT} = (-3.88e^{-6} \times T^2) + (-1.15e^{-2} \times T) + 1.8639$ where T is the temperature	$T_A = -55^\circ C$	2.457	2.485	2.512	V
	$T_A = -40^\circ C$	2.292	2.318	2.343	
	$T_A = -30^\circ C$	2.181	2.205	2.230	
	$T_A = -20^\circ C$	2.069	2.092	2.116	
	$T_A = 0^\circ C$	1.842	1.864	1.886	
	$T_A = 25^\circ C$	1.556	1.574	1.592	
	$T_A = 50^\circ C$	1.255	1.279	1.303	
	$T_A = 85^\circ C$	0.833	0.859	0.884	
	$T_A = 130^\circ C$	0.272	0.303	0.335	

Table 4. Quadratic output equation for operations over the full voltage range ($V_{CC} = 2.4V$ to $5.5V$)

Parameter ⁽¹⁾	Conditions	Min	Max	Unit
Temperature error based on: $V_{OUT} = (-3.88e^{-6} \times T^2) + (-1.15e^{-2} \times T) + 1.8639$, where T is the temperature	$T_A = -55^\circ C^{(2) (3)}$	2.457	2.531	V
	$T_A = -40^\circ C^{(2)}$	2.292	2.362	
	$T_A = -30^\circ C$	2.180	2.249	
	$T_A = -20^\circ C$	2.068	2.135	
	$T_A = 0^\circ C$	1.841	1.904	
	$T_A = 25^\circ C$	1.555	1.610	
	$T_A = 50^\circ C$	1.254	1.322	
	$T_A = 85^\circ C$	0.832	0.903	
	$T_A = 130^\circ C^{(3)}$	0.271	0.353	

1. V_{OUT} tolerance is $\pm 4\%$ (temperature grade 9 only).
2. Valid for V_{CC} min = 2.7V.
3. Valid for temperature grade 7 only.

3 Maximum rating

Stressing the device above the rating listed in the Absolute Maximum Ratings” table may cause permanent damage to the device. These are stress ratings only and operation of the device at these or any other conditions above those indicated in the Operating sections of this specification is not implied. Exposure to Absolute Maximum Rating conditions for extended periods may affect device reliability. Refer also to the STMicroelectronics SURE Program and other relevant quality documents.

Table 5. Absolute maximum ratings

Symbol	Parameter		Value	Unit
T _{STG}	Storage temperature		-65 to +150	°C
T _{SLD} ⁽¹⁾	Lead solder temperature for 10 seconds		260	°C
V _O	Output voltage		-0.6 to V _{CC} + 0.6	V
V _{CC}	Supply voltage		-0.2 to 6.5	V
I _O	Output current		10	mA
T _{J(max)}	Maximum junction temperature		150	°C
θ _{JA}	Thermal resistance	SOT323-5 (SC70-5)	331.4	°C/W
		UDFN	160.2	°C/W
T _A ⁽²⁾	Ambient operating temperature	Grade 7	-55 to 130	°C
		Grade 9	-40 to 85	°C

1. Reflow at peak temperature of 255°C to 260°C for < 30 seconds (total thermal budget not to exceed 180°C for between 90 to 150 seconds).
2. Grade 7: STLM20DD7F and STLM20W87F
Grade 9: STLM20DD9F and STLM20W89F.

4 DC and AC characteristics

This section summarizes the DC and AC characteristics of the device. The parameters in the DC and AC characteristics table that follows are derived from tests performed under the test conditions (see [Table 6 on page 10](#)). Designers should check that the operating conditions in their circuit match the operating conditions when relying on the quoted parameters.

Table 6. DC and AC characteristics

Sym	Description	Test condition ⁽¹⁾	Min	Typ ⁽²⁾	Max	Unit
V _{CC}	Supply voltage	T _A = -30°C to 130°C	2.4		5.5	V
		T _A = -55°C to 130°C or -40°C to 85°C	2.7		5.5	V
V _O	Output voltage	T _A = 0°C		1.8639		V
	Temperature to voltage error ⁽³⁾ V _O = (-3.88E-6 * T2) + (-1.15E-2 * T) + 1.8639V	T _A = 25°C to 30°C			±1.5	°C
		T _A = 125°C to 130°C			±2.5	°C
		T _A = 80°C to 85°C			±2.1	°C
		T _A = 0°C			±1.9	°C
		T _A = -40°C			±2.3	°C
		T _A = -55°C			±2.5	°C
I _Q	Quiescent current	2.4V ≤ V _{CC} ≤ 5.5V		4.8	8	μA
	Sensor gain (temperature sensitivity or average slope), V _O = -11.77mV/°C * T + 1.860V	-30°C ≤ T _A ≤ 100°C	-11.4	-11.77	-12.2	mV/°C
	Non-linearity	-20°C ≤ T _A ≤ 80°C		±0.4		%
ΔI _Q	Change of quiescent current	2.4V ≤ V _{CC} ≤ 5.5V		0.7		μA
T _C V _O	Temperature coefficient of quiescent current			-11		nA/°C
I _{SD}	Shutdown current	V _{CC} ≤ 0.8V		0.02		μA
Z _O	Output impedance	0μA ≤ I _L ≤ 16μA ⁽⁴⁾⁽⁵⁾			160	Ω
RegL	Load regulation ⁽⁶⁾				-2.5	mV
Regl1	Line regulation	2.4V ≤ V _{CC} ≤ 5.0V			3.3	mV/V
Regl2		5.0V ≤ V _{CC} ≤ 5.5V			11	mV

- Valid for Ambient Operating Temperature: T_A = -55 to 130°C or T_A = -40 to 85°C; V_{CC} = 2.7V (except where noted).
- T_J = T_A = 25°C.
- Error accuracy is between the measured and calculated output voltage at specified conditions of voltage, current, and temperature.
- With negative current flowing into STLM20 and positive current flowing out, can typically sink less than 1μA and source is 16μA.
- Over the supply range of 2.4 to 5.5V.
- Measured at constant junction temperature, with pulse testing and low duty cycle. Output changes due to heating may be calculated by multiplying internal dissipation by thermal resistance.

5 Capacitive load

The STLM20 will handle capacitive loads of up to 300pF. Over the specified temperature range, the STLM20 has a maximum output impedance of 160Ω.

In a noisy environment, it may be advisable to add some filtering to minimize noise in the output voltage. A 0.1μF capacitor added between the supply voltage and ground is recommended.

In an extremely noisy environment, it may be necessary to add a low-pass filter network to the output of the device. A 1μF capacitor, in addition to the output impedance of the device, and a 200Ω series resistor, will provide a low-pass filter that will pass the slow thermal time constant of the STLM20, while filtering the higher frequency noise.

Figure 3. Filter network for noisy environments or capacitive loads > 300pF

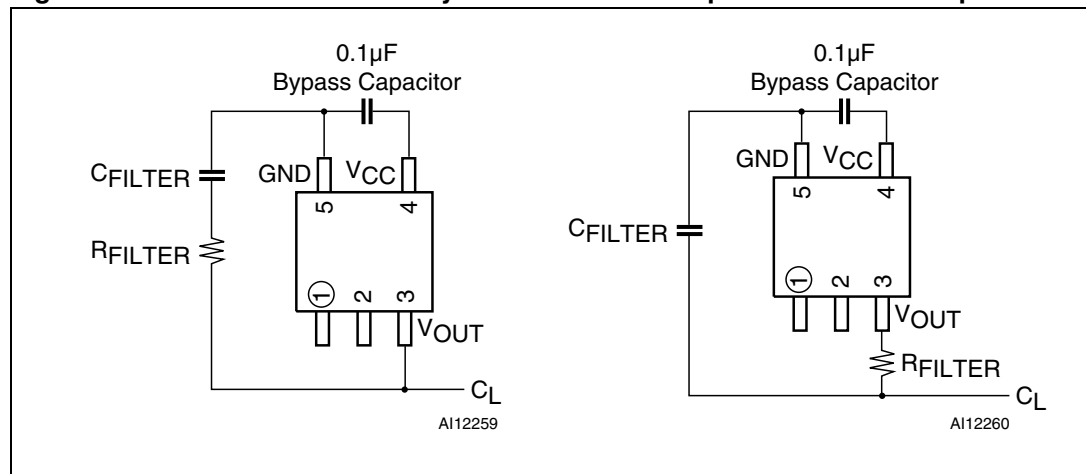

Table 7. Resistor/capacitor combinations for the filter network

R_{FILTER}	C_{FILTER}
200Ω	1μF
470Ω	0.1μF
680Ω	0.01μF
1000Ω	1000pF
10kΩ	100pF
100kΩ	10pF

6 Typical operating characteristics

The graph shown in [Figure 6](#) represents V_{OUT} according to temperature.

Figure 4. V_{OUT} vs. Temperature

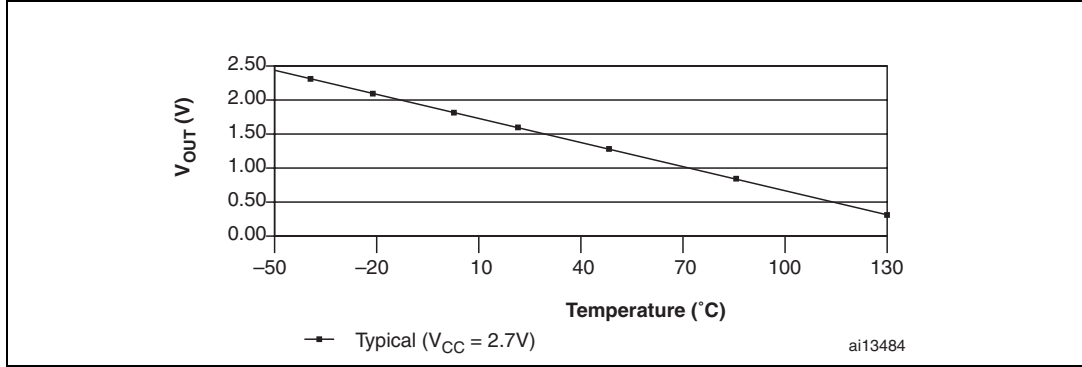

7 Package mechanical

In order to meet environmental requirements, ST offers these devices in ECOPACK[®] packages. These packages have a Lead-free second level interconnect. The category of second Level Interconnect is marked on the package and on the inner box label, in compliance with JEDEC Standard JESD97. The maximum ratings related to soldering conditions are also marked on the inner box label. ECOPACK is an ST trademark. ECOPACK specifications are available at: www.st.com.

Figure 5. SOT323-5 – 5-lead small outline transistor package outline

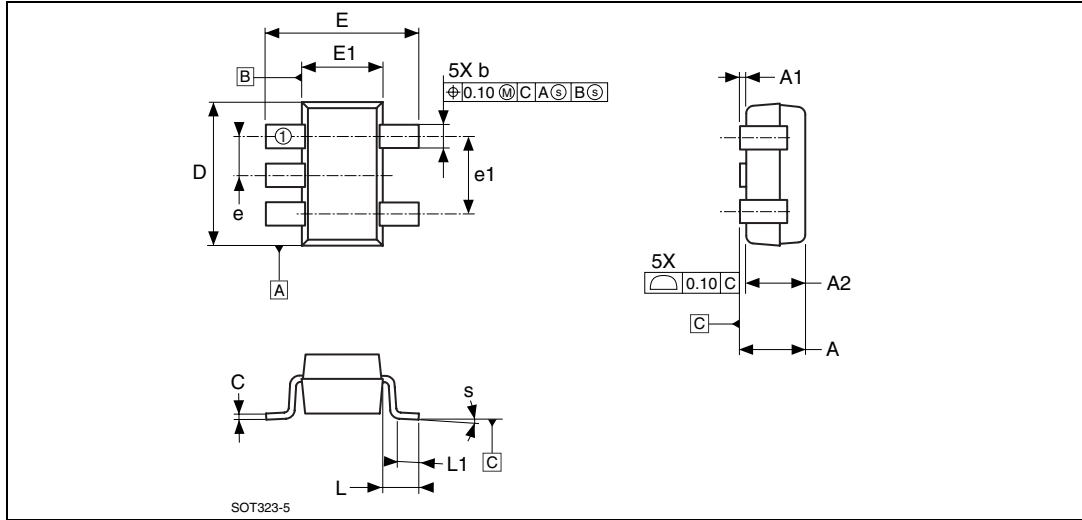

1. Drawing is not to scale.

Table 8. SOT323-5 – 5-lead small outline transistor package mechanical data

Symbol	mm			inches		
	Typ	Min	Max	Typ	Min	Max
A	–	0.80	1.10	–	0.031	0.043
A1	–	0	0.10	–	0	0.004
A2	0.90	–	–	0.035	–	–
b	–	0.15	0.30	–	0.006	0.012
C	–	0.10	0.20	–	0.004	0.008
D	2.00	1.90	2.10	0.079	0.075	0.083
E	–	1.80	2.40	–	0.071	0.094
E1	1.25	1.15	1.35	0.049	0.045	0.053
e	0.65	–	–	0.026	–	–
e1	1.30	–	–	0.051	–	–
L	0.52	–	–	0.020	–	–
L1	0.40	0.35	0.45	0.016	0.014	0.018
s	–	0°	5°	–	0°	5°

Figure 6. UDFN – 4-lead package outline

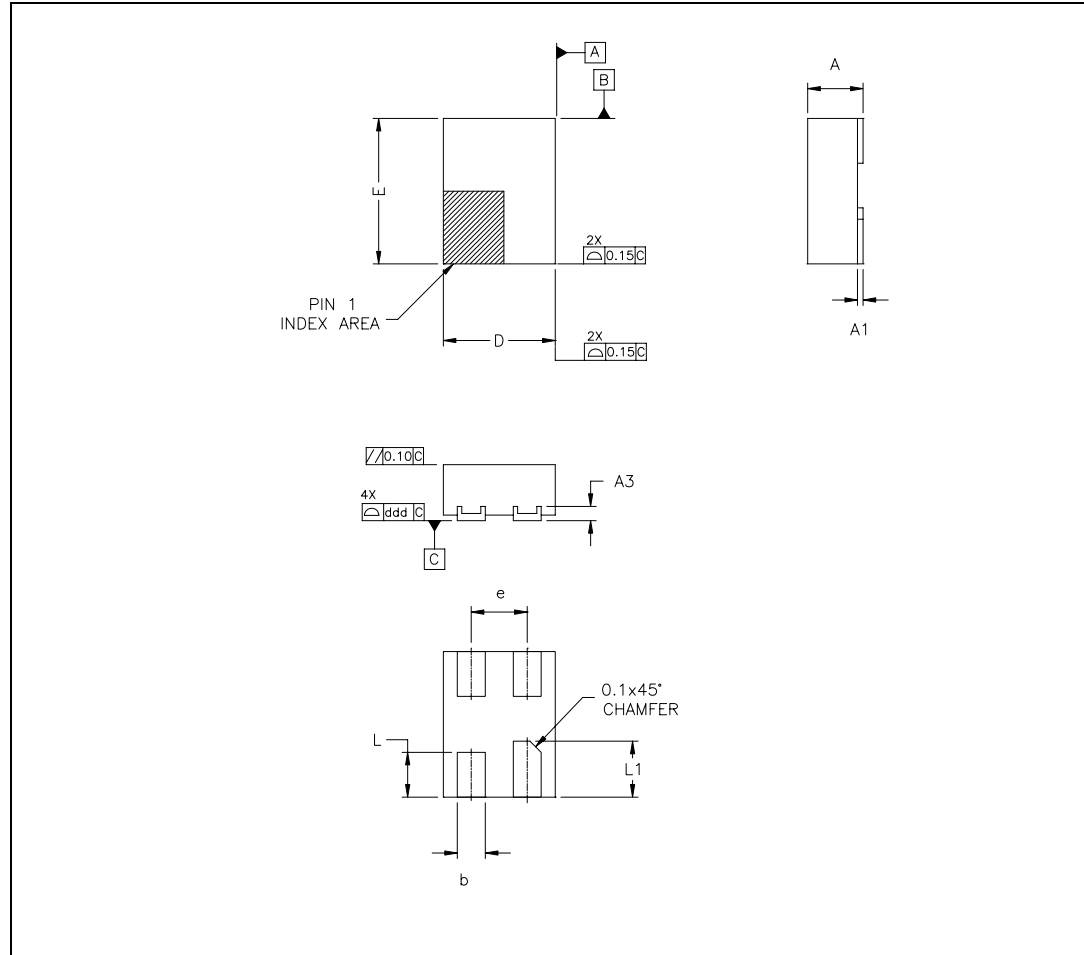

1. Drawing is not to scale.

Table 9. UDFN - 4 lead mechanical data

Symbol	mm			inches		
	Min	Typ	Max	Min	Typ	Max
A	0.45	0.50	0.55	0.018	0.020	0.022
A1	0	0.025	0.05	0	0.001	0.002
A3	0.119	0.127	0.177	0.0046	0.0050	0.0069
b	0.20	0.25	0.30	0.008	0.010	0.012
D	0.95	1.00	1.05	0.037	0.039	0.041
E	1.25	1.30	1.35	0.049	0.051	0.053
e	0.45	0.50	0.55	0.018	0.020	0.022
L	0.35	0.40	0.45	0.014	0.016	0.018
L1	0.45	0.50	0.55	0.018	0.020	0.022
ddd	0	0.04	0.08	0	0.0016	0.0031

8 Part numbering

Table 10. Ordering information scheme

<p>Example: STLM20 DD 9 F</p> <hr style="border: 0.5px solid black;"/> <p>Device type STLM20</p> <p>Package W8 = SOT323-5 (SC70-5)⁽¹⁾ DD= UDFN - ultra thin DFN4 lead⁽²⁾</p> <p>Temperature range 7 = -55 to 130°C 9 = -40 to 85°C</p> <p>Shipping method F = ECOPACK package, tape & reel</p> <p>1. Available in temperature grade 7 (-55 to 130°C) only. 2. Available in temperature grade 9 (-40 to 85°C) only.</p>	<div style="text-align: center; padding-top: 10px;"> STLM20 </div>
--	--

Table 11. Marking description

Part number	Package	Marking
STLM20W8	SOT323-5(SC70-5)	M20
STLM20DD	UDFN	20

For other options, or for more information on any aspect of this device, please contact the ST Sales Office nearest you.

9 Revision history

Table 12. Revision history

Date	Revision	Changes
28-Jun-2006	1	Initial release.
19-Jul-2006	2	Added Table 11: Marking description
28-Aug-2006	3	Added a footnote concerning package availability in Features on page 1 and to Table 10 and Table 11 ; updated package mechanical data in Table 9
05-Sep-2006	4	Amended text in the Features on page 1, Section 1: Summary description, Section 2: Transfer function, Table 6 , and Table 10 to elucidate that two packages exist each with specific temperature ranges: SOT323-5 (SC70-5) 5-lead package (–55 to 130°C) and UDFN 4-lead package (–40 to 85°C)
25-Sep-2006	5	Updated Operating Temperature Ranges (now 7 and 9); updated Table 6: DC and AC characteristics
10-Oct-2006	6	Table 3: Quadratic output equation ($V_{CC} = 2.7V$) and Table 4: Quadratic output equation for operations over the full voltage range ($V_{CC} = 2.4V$ to $5.5V$) added. Section 6: Typical operating characteristics added. T_A added to Table 5: Absolute maximum ratings .
04-Dec-2006	7	Document status updated to full datasheet; updated text in the title of Table 4: Quadratic output equation for operations over the full voltage range ($V_{CC} = 2.4V$ to $5.5V$) ; added footnotes regarding temperature ranges in Table 10: Ordering information scheme .
08-Feb-2007	8	Added thermal resistance in Table 5: Absolute maximum ratings .
09-May-2007	9	Modified Equation 1, 2, and 3 .

Please Read Carefully:

Information in this document is provided solely in connection with ST products. STMicroelectronics NV and its subsidiaries ("ST") reserve the right to make changes, corrections, modifications or improvements, to this document, and the products and services described herein at any time, without notice.

All ST products are sold pursuant to ST's terms and conditions of sale.

Purchasers are solely responsible for the choice, selection and use of the ST products and services described herein, and ST assumes no liability whatsoever relating to the choice, selection or use of the ST products and services described herein.

No license, express or implied, by estoppel or otherwise, to any intellectual property rights is granted under this document. If any part of this document refers to any third party products or services it shall not be deemed a license grant by ST for the use of such third party products or services, or any intellectual property contained therein or considered as a warranty covering the use in any manner whatsoever of such third party products or services or any intellectual property contained therein.

UNLESS OTHERWISE SET FORTH IN ST'S TERMS AND CONDITIONS OF SALE ST DISCLAIMS ANY EXPRESS OR IMPLIED WARRANTY WITH RESPECT TO THE USE AND/OR SALE OF ST PRODUCTS INCLUDING WITHOUT LIMITATION IMPLIED WARRANTIES OF MERCHANTABILITY, FITNESS FOR A PARTICULAR PURPOSE (AND THEIR EQUIVALENTS UNDER THE LAWS OF ANY JURISDICTION), OR INFRINGEMENT OF ANY PATENT, COPYRIGHT OR OTHER INTELLECTUAL PROPERTY RIGHT.

UNLESS EXPRESSLY APPROVED IN WRITING BY AN AUTHORIZED ST REPRESENTATIVE, ST PRODUCTS ARE NOT RECOMMENDED, AUTHORIZED OR WARRANTED FOR USE IN MILITARY, AIR CRAFT, SPACE, LIFE SAVING, OR LIFE SUSTAINING APPLICATIONS, NOR IN PRODUCTS OR SYSTEMS WHERE FAILURE OR MALFUNCTION MAY RESULT IN PERSONAL INJURY, DEATH, OR SEVERE PROPERTY OR ENVIRONMENTAL DAMAGE. ST PRODUCTS WHICH ARE NOT SPECIFIED AS "AUTOMOTIVE GRADE" MAY ONLY BE USED IN AUTOMOTIVE APPLICATIONS AT USER'S OWN RISK.

Resale of ST products with provisions different from the statements and/or technical features set forth in this document shall immediately void any warranty granted by ST for the ST product or service described herein and shall not create or extend in any manner whatsoever, any liability of ST.

ST and the ST logo are trademarks or registered trademarks of ST in various countries.

Information in this document supersedes and replaces all information previously supplied.

The ST logo is a registered trademark of STMicroelectronics. All other names are the property of their respective owners.

© 2007 STMicroelectronics - All rights reserved

STMicroelectronics group of companies

Australia - Belgium - Brazil - Canada - China - Czech Republic - Finland - France - Germany - Hong Kong - India - Israel - Italy - Japan - Malaysia - Malta - Morocco - Singapore - Spain - Sweden - Switzerland - United Kingdom - United States of America

www.st.com



SUNSTAR商斯达实业集团是集研发、生产、工程、销售、代理经销、技术咨询、信息服务等为一体的高科技企业，是专业高科技电子产品生产厂家，是具有 10 多年历史的专业电子元器件供应商，是中国最早和最大的仓储式连锁规模经营大型综合电子零部件代理分销商之一，是一家专业代理和分销世界各大品牌 IC 芯片和电子元器件的连锁经营综合性国际公司。在香港、北京、深圳、上海、西安、成都等全国主要电子市场设有直属分公司和产品展示展销窗口门市部专卖店及代理分销商，已在全国范围内建成强大统一的供货和代理分销网络。我们专业代理经销、开发生产电子元器件、集成电路、传感器、微波光电元器件、工控机/DOC/DOM 电子盘、专用电路、单片机开发、MCU/DSP/ARM/FPGA 软件硬件、二极管、三极管、模块等，是您可靠的一站式现货配套供应商、方案提供商、部件功能模块开发配套商。专业以现代信息产业（计算机、通讯及传感器）三大支柱之一的传感器为主营业务，专业经营各类传感器的代理、销售生产、网络信息、科技图书资料及配套产品设计、工程开发。我们的专业网站——中国传感器科技信息网（全球传感器数据库）www.SENSOR-IC.COM 服务于全球高科技生产商及贸易商，为企业科技产品开发提供技术交流平台。欢迎各厂商互通有无、交换信息、交换链接、发布寻求代理信息。欢迎国外高科技传感器、变送器、执行器、自动控制产品厂商介绍产品到中国，共同开拓市场。本网站是关于各种传感器-变送器-仪器仪表及工业自动化大型专业网站，深入到工业控制、系统工程计 测量、自动化、安防报警、消费电子等众多领域，把最新的传感器-变送器-仪器仪表买卖信息，最新技术供求，最新采购商，行业动态，发展方向，最新的技术应用和市场资讯及时的传递给广大科技开发、科学研究、产品设计人员。本网站已成功为石油、化工、电力、医药、生物、航空、航天、国防、能源、冶金、电子、工业、农业、交通、汽车、矿山、煤炭、纺织、信息、通信、IT、安防、环保、印刷、科研、气象、仪器仪表等领域从事科学研究、产品设计、开发、生产制造的科技人员、管理人员、和采购人员提供满意服务。我们公司专业生产、代理、经销、销售各种传感器、变送器、敏感元器件、开关、执行器、仪器仪表、自动化控制系统：专业从事设计、生产、销售各种传感器、变送器、各种测控仪表、热工仪表、现场控制器、计算机控制系统、数据采集系统、各类环境监控系统、专用控制系统应用软件以及嵌入式系统开发及应用等工作。如热敏电阻、压敏电阻、温度传感器、温度变送器、湿度传感器、湿度变送器、气体传感器、气体变送器、压力传感器、压力变送、称重传感器、物（液）位传感器、物（液）位变送器、流量传感器、流量变送器、电流（压）传感器、溶氧传感器、霍尔传感器、图像传感器、超声波传感器、位移传感器、速度传感器、加速度传感器、扭距传感器、红外传感器、紫外传感器、火焰传感器、激光传感器、振动传感器、轴角传感器、光电传感器、接近传感器、干簧管传感器、继电器传感器、微型电泵、磁敏（阻）传感器、压力开关、接近开关、光电开关、色标传感器、光纤传感器、齿轮测速传感器、时间继电器、计数器、计米器、温控仪、固态继电器、调压模块、电磁铁、电压表、电流表等特殊传感器。同时承接传感器应用电路、产品设计和自动化工程项目。

更多产品请看本公司产品专用销售网站：

商斯达中国传感器科技信息网：<http://www.sensor-ic.com/>

商斯达工控安防网：<http://www.pc-ps.net/>

商斯达电子元器件网：<http://www.sunstare.com/>

商斯达微波光电产品网：[HTTP://www.rfoe.net/](http://www.rfoe.net/)

商斯达消费电子产品网：<http://www.icasic.com/>

商斯达军工产品网：<http://www.junpinic.com/>

商斯达实业科技产品网：<http://www.sunstars.cn/> 传感器销售热线：

地址：深圳市福田区福华路福庆街鸿图大厦 1602 室

电话：0755-83607652 83376489 83376549 83370250 83370251 82500323

传真：0755-83376182 (0) 13902971329 MSN: SUNS888@hotmail.com

邮编：518033 E-mail: szss20@163.com QQ: 195847376

深圳赛格展销部：深圳华强北路赛格电子市场 2583 号 电话：0755-83665529 25059422

技术支持：0755-83394033 13501568376

欢迎索取免费详细资料、设计指南和光盘；产品凡多，未能尽录，欢迎来电查询。

北京分公司：北京海淀区知春路 132 号中发电子大厦 3097 号

TEL: 010-81159046 82615020 13501189838 FAX: 010-62543996

上海分公司：上海市北京东路 668 号上海赛格电子市场 D125 号

TEL: 021-28311762 56703037 13701955389 FAX: 021-56703037

西安分公司：西安高新开发区 20 所(中国电子科技集团导航技术研究所)

西安劳动南路 88 号电子商城二楼 D23 号

TEL: 029-81022619 13072977981 FAX:029-88789382