



Voltage Output Temperature Sensor with Signal Conditioning

AD22100*

FEATURES

- 200°C Temperature Span
- Accuracy Better than $\pm 2\%$ of Full Scale
- Linearity Better than $\pm 1\%$ of Full Scale
- Temperature Coefficient of 22.5 mV/°C
- Output Proportional to Temperature $\times V_+$
- Single Supply Operation
- Reverse Voltage Protection
- Minimal Self Heating
- High Level, Low Impedance Output

APPLICATIONS

- HVAC Systems
- System Temperature Compensation
- Board Level Temperature Sensing
- Electronic Thermostats

MARKETS

- Industrial Process Control
- Instrumentation
- Automotive

SIMPLIFIED BLOCK DIAGRAM

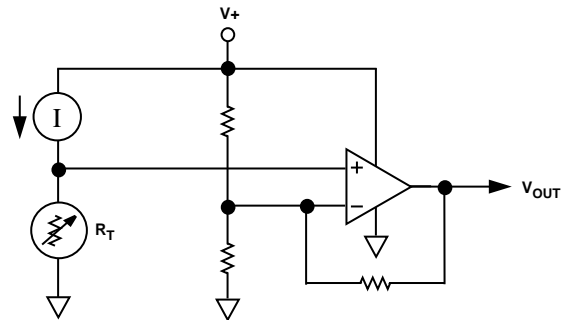

GENERAL DESCRIPTION

The AD22100 is a monolithic temperature sensor with on-chip signal conditioning. It can be operated over the temperature range -50°C to $+150^{\circ}\text{C}$, making it ideal for use in numerous HVAC, instrumentation and automotive applications.

The signal conditioning eliminates the need for any trimming, buffering or linearization circuitry, greatly simplifying the system design and reducing the overall system cost.

The output voltage is proportional to the temperature times the supply voltage (ratiometric). The output swings from 0.25 V at -50°C to 4.75 V at $+150^{\circ}\text{C}$ using a single +5.0 V supply.

Due to its ratiometric nature, the AD22100 offers a cost effective solution when interfacing to an analog-to-digital converter. This is accomplished by using the ADC's +5 V power supply as a reference to both the ADC and the AD22100 (See Figure 1), eliminating the need for and cost of a precision reference.

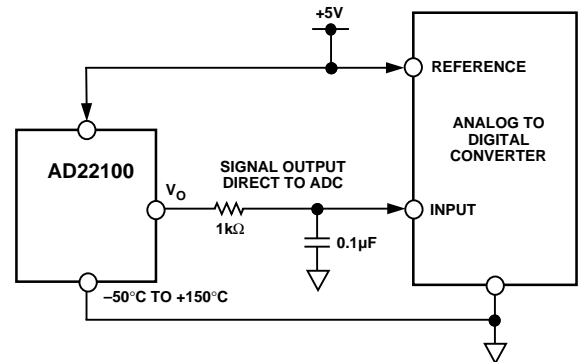

Figure 1. Application Circuit

*Protected by U.S. Patent Nos. 5030849 and 5243319.

REV. B

Information furnished by Analog Devices is believed to be accurate and reliable. However, no responsibility is assumed by Analog Devices for its use, nor for any infringements of patents or other rights of third parties which may result from its use. No license is granted by implication or otherwise under any patent or patent rights of Analog Devices.

© Analog Devices, Inc., 1994

One Technology Way, P.O. Box 9106, Norwood, MA 02062-9106, U.S.A.
Tel: 617/329-4700 Fax: 617/326-8703

AD22100-SPECIFICATIONS ($T_A = +25^\circ\text{C}$ and $V_+ = +4\text{ V}$ to $+6\text{ V}$ unless otherwise noted)

Parameter	AD22100K			AD22100A			AD22100S			Units
	Min	Typ	Max	Min	Typ	Max	Min	Typ	Max	
TRANSFER FUNCTION	$V_{\text{OUT}} = (V_+/5\text{ V}) \times [1.375\text{ V} + (22.5\text{ mV}/^\circ\text{C}) \times T_A]$									V
TEMPERATURE COEFFICIENT	$(V_+/5\text{ V}) \times 22.5$									mV/°C
TOTAL ERROR										
Initial Error										
$T_A = +25^\circ\text{C}$	±0.5 ±2.0			±1.0 ±2.0			±1.0 ±2.0			°C
Error over Temperature										
$T_A = T_{\text{MIN}}$	±0.75 ±2.0			±2.0 ±3.7			±3.0 ±4.0			°C
$T_A = T_{\text{MAX}}$	±0.75 ±2.0			±2.0 ±3.0			±3.0 ±4.0			°C
Nonlinearity										
$T_A = T_{\text{MIN}}$ to T_{MAX}	0.5			0.5			1.0			% FS ¹
OUTPUT CHARACTERISTICS										
Nominal Output Voltage										
$V_+ = 5.0\text{ V}$, $T_A = 0^\circ\text{C}$	1.375									V
$V_+ = 5.0\text{ V}$, $T_A = +100^\circ\text{C}$	3.625									V
$V_+ = 5.0\text{ V}$, $T_A = -40^\circ\text{C}$				0.475						V
$V_+ = 5.0\text{ V}$, $T_A = +85^\circ\text{C}$				3.288						V
$V_+ = 5.0\text{ V}$, $T_A = -50^\circ\text{C}$							0.250			V
$V_+ = 5.0\text{ V}$, $T_A = +150^\circ\text{C}$							4.750			V
POWER SUPPLY										
Operating Voltage	+4.0	+5.0	+6.0	+4.0	+5.0	+6.0	+4.0	+5.0	+6.0	V
Quiescent Current	500 650			500 650			500 650			μA
TEMPERATURE RANGE										
Guaranteed Temperature Range	0	+100		-40	+85		-50	+150		°C
Operating Temperature Range	-50	+150		-50	+150		-50	+150		°C
PACKAGE	TO-92 SOIC			TO-92 SOIC			TO-92 SOIC			

Specifications subject to change without notice.

CHIP SPECIFICATIONS ($T_A = +25^\circ\text{C}$ and $V_+ = +5.0\text{ V}$ unless otherwise noted)

Parameter	Min	Typ	Max	Units	
TRANSFER FUNCTION	$V_{\text{OUT}} = (V_+/5\text{ V}) \times [1.375 + 22.5\text{ mV}/^\circ\text{C} \times T_A]$ V				
TEMPERATURE COEFFICIENT	$(V_+/5\text{ V}) \times 22.5$				
OUTPUT CHARACTERISTICS					
Error					
$T_A = +25^\circ\text{C}$	±0.5		±2.0		°C
Nominal Output Voltage					
$T_A = +25^\circ\text{C}$	1.938				V
POWER SUPPLY					
Operating Voltage	+4.0	+5.0	+6.0	V	
Quiescent Current	500		650		μA
TEMPERATURE RANGE					
Guaranteed Temperature Range	25				°C
Operating Temperature Range	-50			+150	°C

NOTES

¹FS (Full Scale) is defined as that of the operating temperature range, -50°C to $+150^\circ\text{C}$. The listed max specification limit applies to the guaranteed temperature range. For example, the AD22100K has a nonlinearity of $(0.5\%) \times (200^\circ\text{C}) = 1^\circ\text{C}$ over the guaranteed temperature range of 0°C to $+100^\circ\text{C}$.

Specifications subject to change without notice.

AD22100

ABSOLUTE MAXIMUM RATINGS¹

Supply Voltage	+10 V
Reversed Continuous Supply Voltage	-10 V
Operating Temperature	-50°C to +150°C
Storage Temperature	-65°C to +160°C
Output Short Circuit to V+ or Ground	Indefinite
Lead Temperature (Soldering, 10 sec)	+300°C

¹Stresses above those listed under "Absolute Maximum Ratings" may cause permanent damage to the device. This is a stress rating only; the functional operation of the device at these or any other conditions above those indicated in the operation sections of this specification is not implied. Exposure to absolute maximum rating conditions for extended periods may affect device reliability.

ORDERING GUIDE

Model/Grade	Guaranteed Temperature Range	Package Description*	Package Option
AD22100 KT	0°C to 100°C	TO-92	TO-92
AD22100 KR	0°C to 100°C	SOIC	SO-8
AD22100 AT	-40°C to +85°C	TO-92	TO-92
AD22100 AR	-40°C to +85°C	SOIC	SO-8
AD22100 ST	-50°C to +150°C	TO-92	TO-92
AD22100 SR	-50°C to +150°C	SOIC	SO-8
AD22100KChips	+25°C	N/A	N/A

*Minimum purchase quantities of 100 pieces for all chip orders.

PIN DESCRIPTION

Mnemonic	Function
V+	Power Supply Input
V _O	Device Output
GND	Ground Pin must be connected to 0 V.
NC	No Connect

PIN CONFIGURATIONS

TO-92

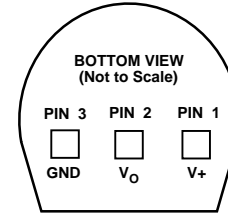

SOIC

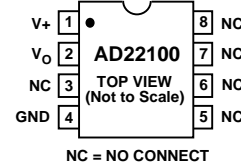

CAUTION

ESD (electrostatic discharge) sensitive device. Electrostatic charges as high as 4000 V readily accumulate on the human body and test equipment and can discharge without detection. Although the AD22100 features proprietary ESD protection circuitry, permanent damage may occur on devices subjected to high energy electrostatic discharges. Therefore, proper ESD precautions are recommended to avoid performance degradation or loss of functionality.



Typical Performance Curves

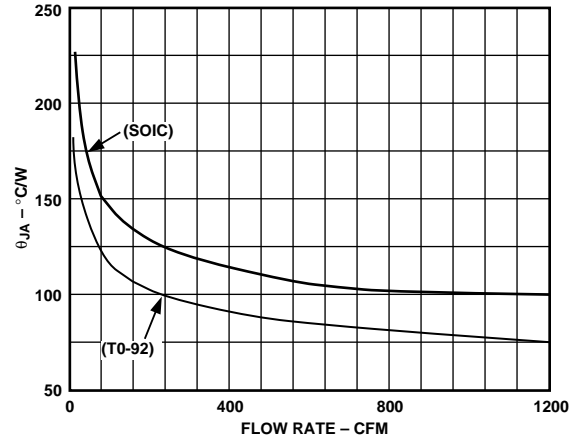
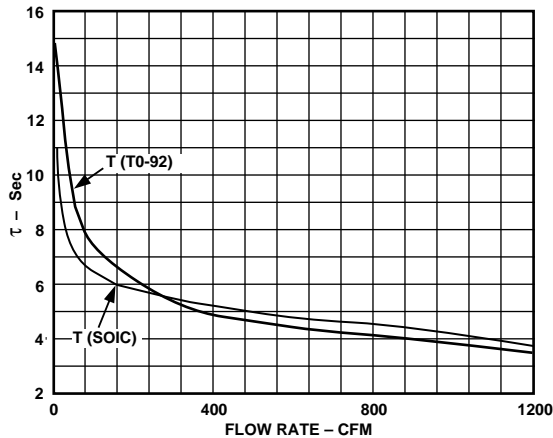

AD22100

THEORY OF OPERATION

The AD22100 is a ratiometric temperature sensor IC whose output voltage is proportional to power supply voltage. The heart of the sensor is a proprietary temperature-dependent resistor, similar to an RTD, which is built into the IC. Figure 4 shows a simplified block diagram of the AD22100.

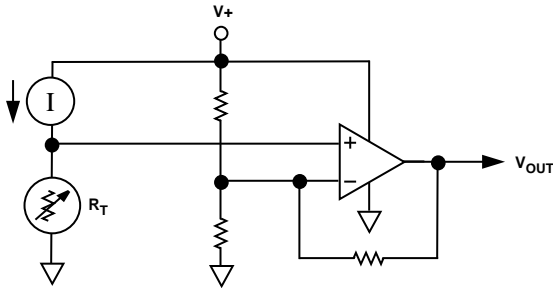

Figure 4. Simplified Block Diagram

The temperature-dependent resistor, labeled R_T , exhibits a change in resistance that is nearly linearly proportional to temperature. This resistor is excited with a current source that is proportional to power supply voltage. The resulting voltage across R_T is therefore both supply voltage proportional and linearly varying with temperature. The remainder of the AD22100 consists of an op amp signal conditioning block that takes the voltage across R_T and applies the proper gain and offset to achieve the following output voltage function:

$$V_{OUT} = (V+/5 V) \times [1.375 V + (22.5 \text{ mV}/^\circ\text{C}) \times T_A]$$

ABSOLUTE ACCURACY AND NONLINEARITY SPECIFICATIONS

Figure 5 graphically depicts the guaranteed limits of accuracy for the AD22100 and shows the performance of a typical part. As the output is very linear, the major sources of error are offset, i.e., error at room temperature, and span error, i.e., deviation from the theoretical 22.5 mV/°C. Demanding applications can achieve improved performance by calibrating these offset and gain errors so that only the residual nonlinearity remains as a significant source of error.

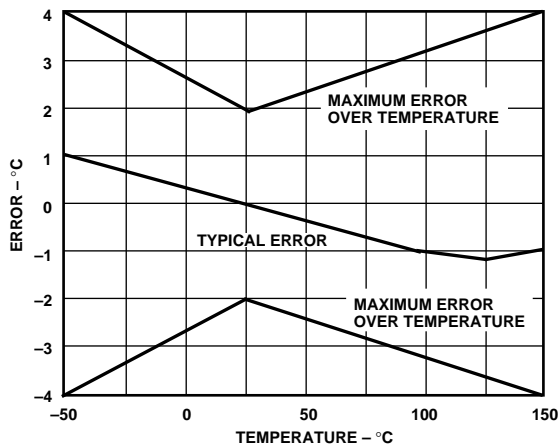

Figure 5. Typical AD22100 Performance

OUTPUT STAGE CONSIDERATIONS

As previously stated, the AD22100 is a voltage output device. A basic understanding of the nature of its output stage is useful for proper application. Note that at the nominal supply voltage of 5.0 V, the output voltage extends from 0.25 V at -50°C to +4.75 V at +150°C. Furthermore, the AD22100 output pin is capable of withstanding an indefinite short circuit to either ground or the power supply. These characteristics are provided by the output stage structure shown in Figure 6.

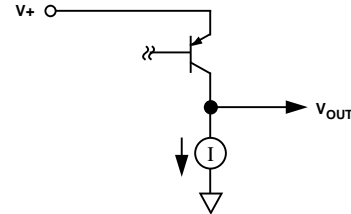

Figure 6. Output Stage Structure

The active portion of the output stage is a PNP transistor with its emitter connected to the $V+$ supply and collector connected to the output node. This PNP transistor sources the required amount of output current. A limited pull-down capability is provided by a fixed current sink of about -80 μA . (Here, “fixed” means the current sink is fairly insensitive to either supply voltage or output loading conditions. The current sink capability is a function of temperature, increasing its pull-down capability at lower temperatures.)

Due to its limited current sinking ability, the AD22100 is incapable of driving loads to the $V+$ power supply and is instead intended to drive grounded loads. A typical value for short circuit current limit is 7 mA, so devices can reliably source 1 mA or 2 mA. However, for best output voltage accuracy and minimal internal self-heating, output current should be kept below 1 mA. Loads connected to the $V+$ power supply should be avoided as the current sinking capability of the AD22100 is fairly limited. These considerations are typically not a problem when driving a microcontroller analog to digital converter input pin (see MICROPROCESSOR A/D INTERFACE ISSUES).

RATIOMETRICITY CONSIDERATIONS

The AD22100 will operate with slightly better accuracy than that listed in the data sheet specifications if the power supply is held constant. This is because the AD22100's output voltage varies with both temperature and supply voltage, with some errors. The ideal transfer function describing the output voltage is:

$$(V+/5 V) \times [1.375 V + (22.5 \text{ mV}/^\circ\text{C}) \times T_A]$$

The ratiometricity error is defined as the percent change away from the ideal transfer function as the power supply voltage changes within the operating range of +4 V to +6 V. For the AD22100 this error is typically less than 1%. A movement from the ideal transfer function by 1% at +25°C, with a supply voltage varying from 5.0 V to 5.50 V, results in a 1.94 mV change in output voltage or 0.08°C error. This error term is greater at higher temperatures because the output (and error term) is directly proportional to temperature. At 150°C, the error in output voltage is 4.75 mV or 0.19°C.

For example, with $V_S = 5.0\text{ V}$, and $T_A = +25^\circ\text{C}$, the nominal output of the AD22100 will be 1.9375 V. At $V_S = 5.50\text{ V}$, the nominal output will be 2.1313 V, an increase of 193.75 mV. A proportionality error of 1% is applied to the 193.75 mV, yielding an error term of 1.9375 mV. This error term translates to a variation in output voltage of 2.1293 V to 2.3332 V. A 1.94 mV error at the output is equivalent to about 0.08°C error in accuracy.

If we substitute 150°C for 25°C in the above example, then the error term translates to a variation in output voltage of 5.2203 V to 5.2298 V. A 4.75 mV error at the output is equivalent to about 0.19°C error in accuracy.

MOUNTING CONSIDERATIONS

If the AD22100 is thermally attached and properly protected, it can be used in any measuring situation where the maximum range of temperatures encountered is between -50°C and $+150^\circ\text{C}$. Because plastic IC packaging technology is employed, excessive mechanical stress must be avoided when fastening the device with a clamp or screw-on heat tab. Thermally conductive epoxy or glue is recommended for typical mounting conditions. In wet or corrosive environments, an electrically isolated metal or ceramic well should be used to shield the AD22100. Because the part has a voltage output (as opposed to current), it offers modest immunity to leakage errors, such as those caused by condensation at low temperatures.

THERMAL ENVIRONMENT EFFECTS

The thermal environment in which the AD22100 is used determines two performance traits: the effect of self-heating on accuracy and the response time of the sensor to rapid changes in temperature. In the first case, a rise in the IC junction temperature above the ambient temperature is a function of two variables; the power consumption of the AD22100 and the thermal resistance between the chip and the ambient environment θ_{JA} . Self-heating error in $^\circ\text{C}$ can be derived by multiplying the power dissipation by θ_{JA} . Because errors of this type can vary widely for surroundings with different heat sinking capacities, it is necessary to specify θ_{JA} under several conditions. Table I shows how the magnitude of self-heating error varies relative to the environment. A typical part will dissipate about 2.2 mW at room temperature with a 5 V supply and negligible output loading. In still air, without a "heat sink," the table below indicates a θ_{JA} of $190^\circ\text{C}/\text{W}$, yielding a temperature rise of 0.4°C . Thermal rise will be considerably less in either moving air or with direct physical connection to a solid (or liquid) body.

Table I. Thermal Resistance (TO-92)

Medium	θ_{JA} ($^\circ\text{C}/\text{Watt}$)	τ (sec) *
Aluminum Block	60	2
Moving Air**		
Without Heat Sink	75	3.5
Still Air		
Without Heat Sink	190	15

*The time constant τ is defined as the time to reach 63.2% of the final temperature change.

**1200 CFM.

Response of the AD22100 output to abrupt changes in ambient temperature can be modeled by a single time constant τ exponential function. Figure 7 shows typical response time plots for a few media of interest.

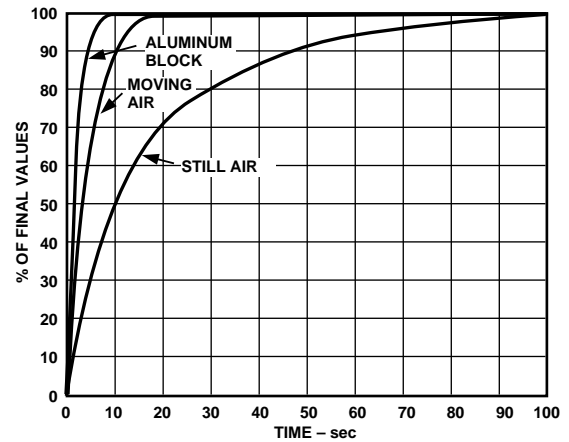

Figure 7. Response Time

The time constant τ is dependent on θ_{JA} and the thermal capacities of the chip and the package. Table I lists the effective τ (time to reach 63.2% of the final value) for a few different media. Copper printed circuit board connections were neglected in the analysis; however, they will sink or conduct heat directly through the AD22100's solder plated copper leads. When faster response is required, a thermally conductive grease or glue between the AD22100 and the surface temperature being measured should be used.

MICROPROCESSOR A/D INTERFACE ISSUES

The AD22100 is especially well suited to providing a low cost temperature measurement capability for microprocessor/microcontroller based systems. Many inexpensive 8-bit microprocessors now offer an onboard 8-bit ADC capability at a modest cost premium. Total "cost of ownership" then becomes a function of the voltage reference and analog signal conditioning necessary to mate the analog sensor with the microprocessor ADC. The AD22100 can provide an ideal low cost system by eliminating the need for a precision voltage reference and any additional active components. The ratiometric nature of the AD22100 allows the microprocessor to use the same power supply as its ADC reference. Variations of hundreds of millivolts in the supply voltage have little effect as both the AD22100 and the ADC use the supply as their reference. The nominal AD22100 signal range of 0.25 V to 4.75 V (-50°C to $+150^\circ\text{C}$) makes good use of the input range of a 0 V to 5 V ADC. A single resistor and capacitor are recommended to provide immunity to the high speed charge dump glitches seen at many microprocessor ADC inputs (see Figure 1).

An 8-bit ADC with a reference of 5 V will have a least significant bit (LSB) size of $5\text{ V}/256 = 19.5\text{ mV}$. This corresponds to a nominal resolution of about 0.87°C .

SUNSTAR商斯达实业集团是集研发、生产、工程、销售、代理经销、技术咨询、信息服务等为一体的高科技企业，是专业高科技电子产品生产厂家，是具有10多年历史的专业电子元器件供应商，是中国最早和最大的仓储式连锁规模经营大型综合电子零部件代理分销商之一，是一家专业代理和分销世界各大品牌IC芯片和电子元器件的连锁经营综合性国际公司。在香港、北京、深圳、上海、西安、成都等全国主要电子市场设有直属分公司和产品展示展销窗口门市部专卖店及代理分销商，已在全国范围内建成强大统一的供货和代理分销网络。我们专业代理经销、开发生产电子元器件、集成电路、传感器、微波光电元器件、工控机/DOC/DOM电子盘、专用电路、单片机开发、MCU/DSP/ARM/FPGA软件硬件、二极管、三极管、模块等，是您可靠的一站式现货配套供应商、方案提供商、部件功能模块开发配套商。专业以现代信息产业（计算机、通讯及传感器）三大支柱之一的传感器为主营业务，专业经营各类传感器的代理、销售生产、网络信息、科技图书资料及配套产品设计、工程开发。我们的专业网站——中国传感器科技信息网（全球传感器数据库）www.SENSOR-IC.COM 服务于全球高科技生产商及贸易商，为企业科技产品开发提供技术交流平台。欢迎各厂商互通有无、交换信息、交换链接、发布寻求代理信息。欢迎国外高科技传感器、变送器、执行器、自动控制产品厂商介绍产品到中国，共同开拓市场。本网站是关于各种传感器-变送器-仪器仪表及工业自动化大型专业网站，深入到工业控制、系统工程计 测量、自动化、安防报警、消费电子等众多领域，把最新的传感器-变送器-仪器仪表买卖信息，最新技术供求，最新采购商，行业动态，发展方向，最新的技术应用和市场资讯及时的传递给广大科技开发、科学研究、产品设计人员。本网站已成功为石油、化工、电力、医药、生物、航空、航天、国防、能源、冶金、电子、工业、农业、交通、汽车、矿山、煤炭、纺织、信息、通信、IT、安防、环保、印刷、科研、气象、仪器仪表等领域从事科学研究、产品设计、开发、生产制造的科技人员、管理人员、和采购人员提供满意服务。我们公司专业生产、代理、经销、销售各种传感器、变送器、敏感元器件、开关、执行器、仪器仪表、自动化控制系统：专业从事设计、生产、销售各种传感器、变送器、各种测控仪表、热工仪表、现场控制器、计算机控制系统、数据采集系统、各类环境监控系统、专用控制系统应用软件以及嵌入式系统开发及应用等工作。如热敏电阻、压敏电阻、温度传感器、温度变送器、湿度传感器、湿度变送器、气体传感器、气体变送器、压力传感器、压力变送、称重传感器、物（液）位传感器、物（液）位变送器、流量传感器、流量变送器、电流（压）传感器、溶氧传感器、霍尔传感器、图像传感器、超声波传感器、位移传感器、速度传感器、加速度传感器、扭距传感器、红外传感器、紫外传感器、火焰传感器、激光传感器、振动传感器、轴角传感器、光电传感器、接近传感器、干簧管传感器、继电器传感器、微型电泵、磁敏（阻）传感器、压力开关、接近开关、光电开关、色标传感器、光纤传感器、齿轮测速传感器、时间继电器、计数器、计米器、温控仪、固态继电器、调压模块、电磁铁、电压表、电流表等特殊传感器。同时承接传感器应用电路、产品设计和自动化工程项目。

更多产品请看本公司产品专用销售网站：

商斯达中国传感器科技信息网：<http://www.sensor-ic.com/>

商斯达工控安防网：<http://www.pc-ps.net/>

商斯达电子元器件网：<http://www.sunstare.com/>

商斯达微波光电产品网：[HTTP://www.rfoe.net/](http://www.rfoe.net/)

商斯达消费电子产品网：<http://www.icasic.com/>

商斯达军工产品网：<http://www.junpinic.com/>

商斯达实业科技产品网：<http://www.sunstars.cn/>传感器销售热线：

地址：深圳市福田区福华路福庆街鸿图大厦1602室

电话：0755-83607652 83376489 83376549 83370250 83370251 82500323

传真：0755-83376182 (0) 13902971329 MSN: SUNS888@hotmail.com

邮编：518033 E-mail: szss20@163.com QQ: 195847376

深圳赛格展销部：深圳华强北路赛格电子市场2583号 电话：0755-83665529 25059422

技术支持：0755-83394033 13501568376

欢迎索取免费详细资料、设计指南和光盘；产品凡多，未能尽录，欢迎来电查询。

北京分公司：北京海淀区知春路132号中发电子大厦3097号

TEL: 010-81159046 82615020 13501189838 FAX: 010-62543996

上海分公司：上海市北京东路668号上海赛格电子市场D125号

TEL: 021-28311762 56703037 13701955389 FAX: 021-56703037

西安分公司：西安高新开发区20所(中国电子科技集团导航技术研究所)

西安劳动南路88号电子商城二楼D23号

TEL: 029-81022619 13072977981 FAX:029-88789382