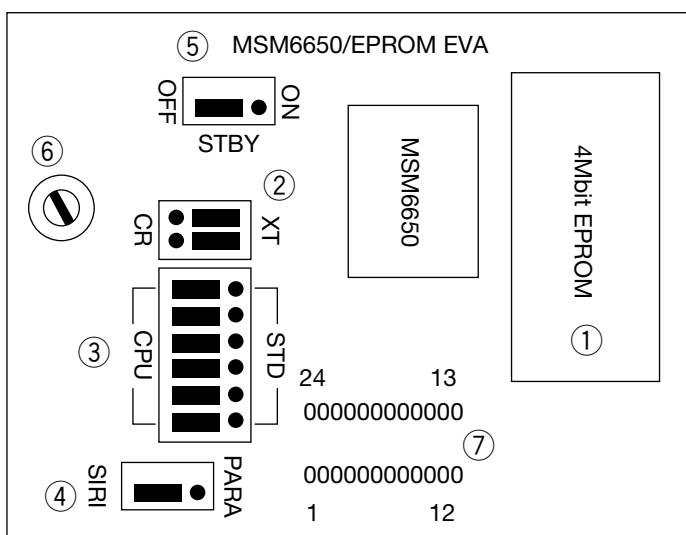

MSM6650 4MegOTP I/F BOARD**4MegOTP Conversion Board****1. BOARD APPEARANCE****2. BOARD SETTING**

- ① 4Mbit EPROM Socket
Insert a 4Mbit EPROM, which is programmed with the voice data through voice analysis.
- ② XT/ \overline{RC} Select jumpers
These jumpers are used to select ceramic oscillation or RC oscillation.
To select ceramic oscillation, set the jumpers ② to the right side.
To select RC oscillation, set the jumpers ② to the left side.
When a microcontroller is used, only ceramic oscillation can be selected.
- ③ Stand-alone/Microcontroller Select Jumpers
These jumpers are used to select Stand-alone Mode or Microcontroller Interface Mode for operation of the MSM6650.
To select Stand-alone Mode, set the jumpers ③ to the right side.
To select Microcontroller Interface Mode, set the jumpers ③ to the left side.
However, set the jumper ④ to the right for Stand-alone Mode and the jumper ⑤ to the left for Microcontroller Interface Mode.
- ④ Serial Input Interface/Parallel Input Interface Select Switch
When a microcontroller is used, this switch selects the serial input of addresses and command data or the parallel input of them.
To select the serial input, set the switch to the left side. To select the parallel input, set the switch to the right side.

- ⑤ **Standby Select Jumper**
When the jumper is set to the right side and The MSM6650 is not activated toward the next phrase within 0.2 second after the voice is terminated, the MSM6650 enters the standby state. (In the standby state, all functions of the MSM6650 are stopped.)
- ⑥ **Variable Resistor for Adjusting Frequency of RC Oscillation**
This variable resistor can change the frequency of RC oscillation. The frequency becomes low when the resistor is turned to the right, and the frequency becomes high when the resistor is turned to the left. (The oscillation frequency is set to 256kHz before shipment)
- ⑦ **External Connection Pins**
The necessary signal lines are connected to the FC cable connector for external connections. The signals for each connector pin are described below.

Signals in Standalone Mode

Connector pin No.	Signal	Connector pin No.	Signal
1	V _{DD}	13	A0
2	NC	14	A1
3	NC	15	A2
4	NC	16	$\overline{\text{TEST}}$
5	OSC3	17	$\overline{\text{RESET}}$
6	NC	18	NC
7	NC	19	NC
8	$\overline{\text{RND}}$	20	$\overline{\text{BUSY}}$
9	SW0	21	NC
10	SW1	22	XT/ $\overline{\text{CR}}$
11	SW2	23	AOUT
12	SW3	24	GND

Signals in Microcontroller Interface Mode

Connector pin No.	Signal	Connector pin No.	Signal
1	V _{DD}	13	I4
2	NC	14	I5/SI
3	NC	15	I6/SD
4	NC	16	$\overline{\text{CH}}$
5	$\overline{\text{CMD}}$	17	$\overline{\text{RESET}}$
6	NC	18	NC
7	NC	19	NC
8	$\overline{\text{ST}}$	20	$\overline{\text{BUSY}}$
9	I0	21	NC
10	I1	22	NAR
11	I2/PORT0	23	AOUT
12	I3/PORT1	24	GND

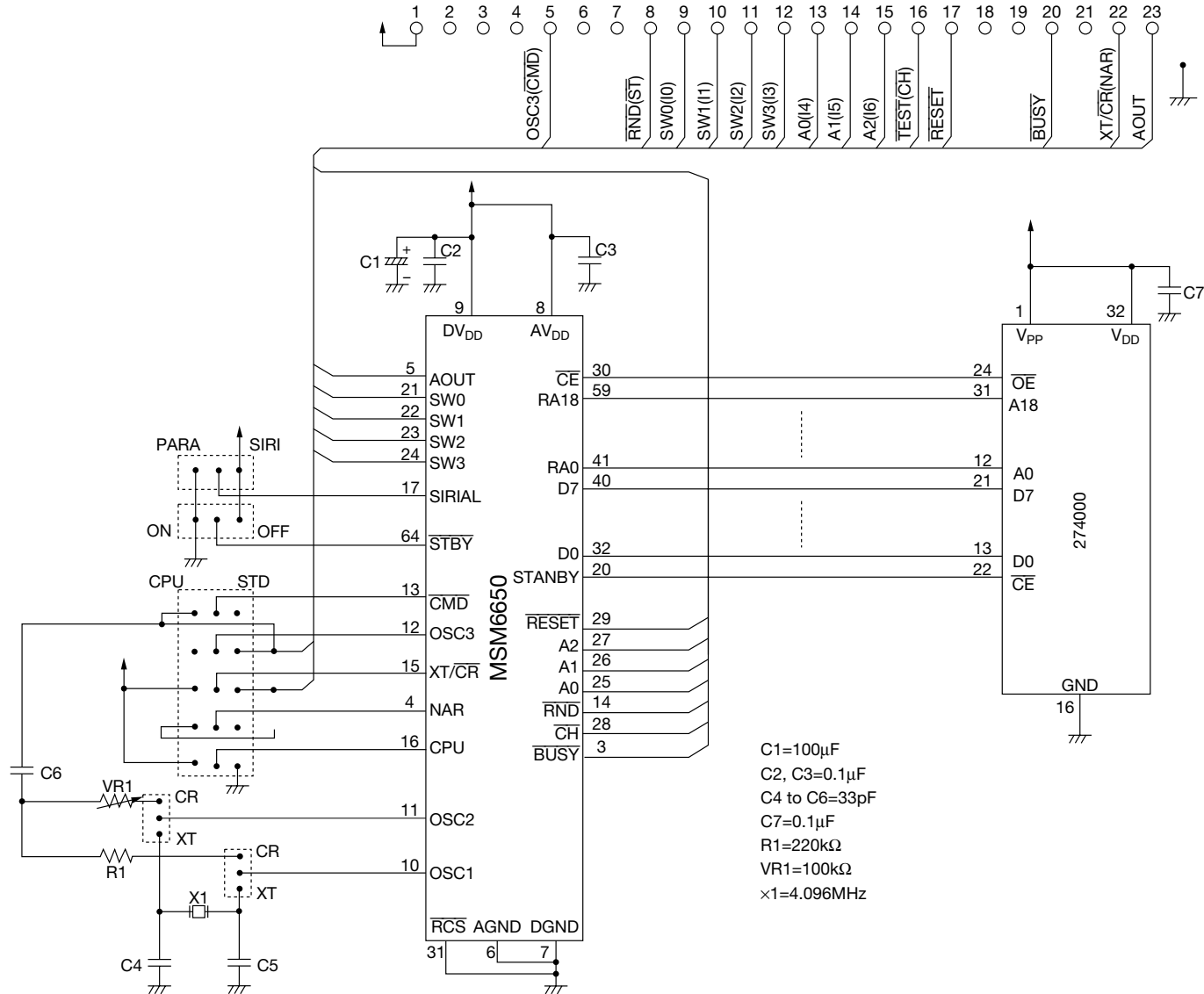

3. CIRCUIT DIAGRAM

4. PATTERN LAYOUT

4-1. Silk Screen

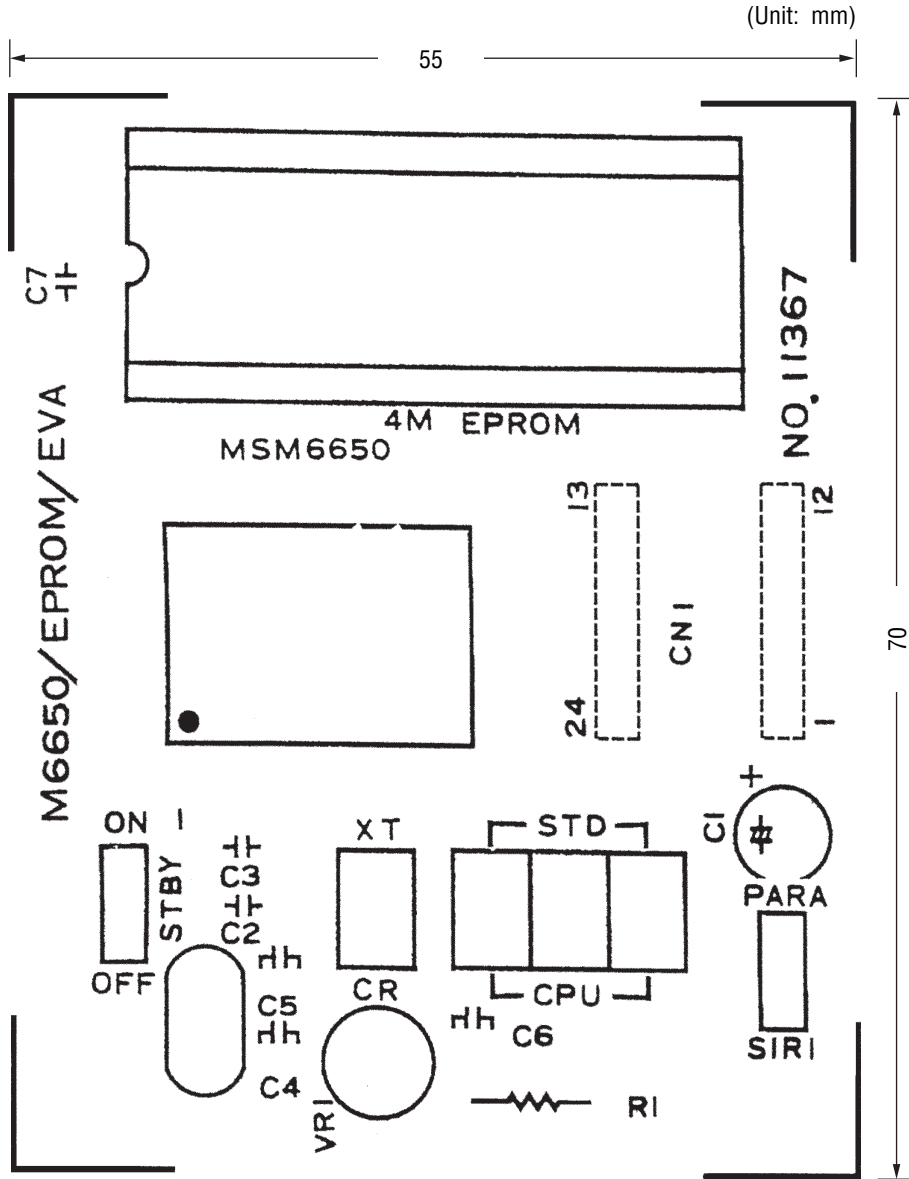

4-2. Mounting Side

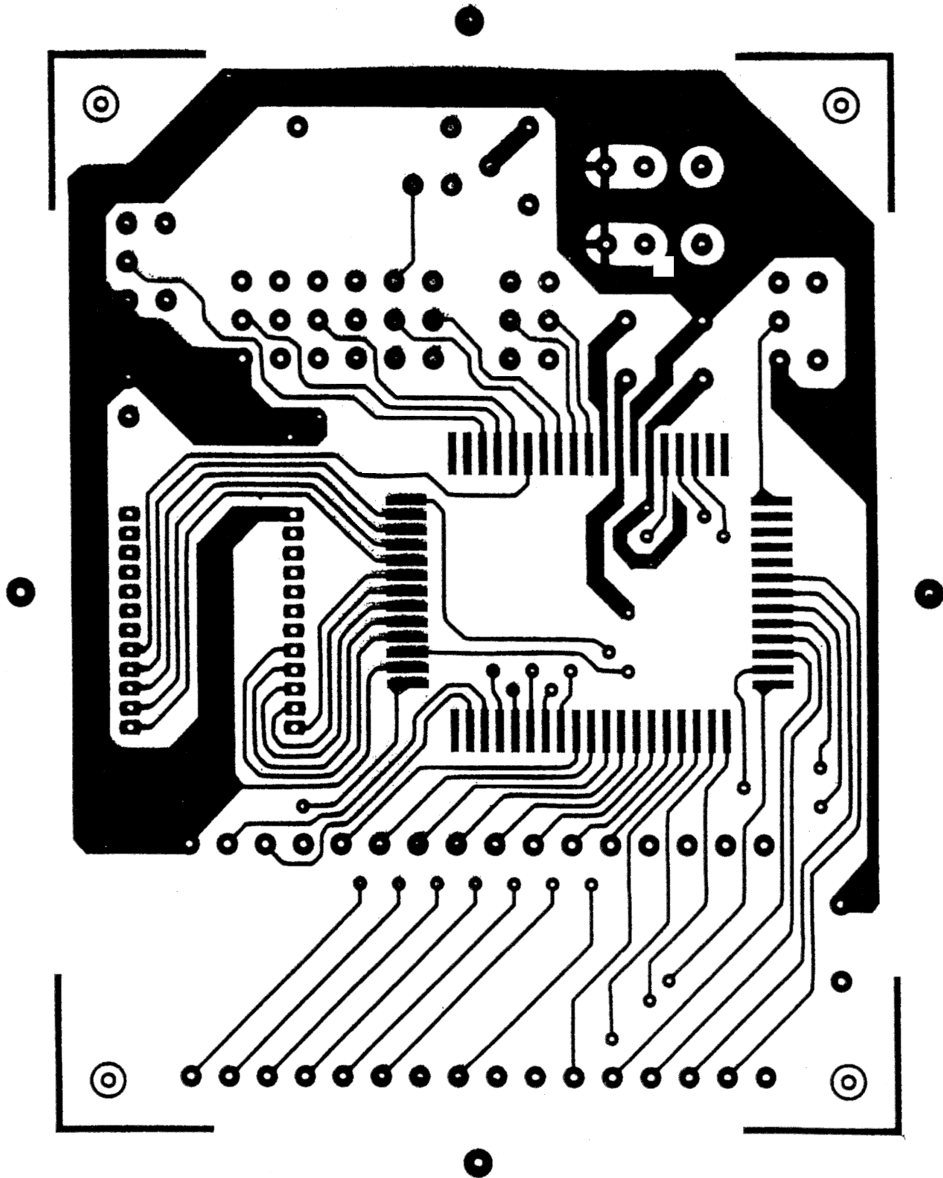

4-3. Solder Side

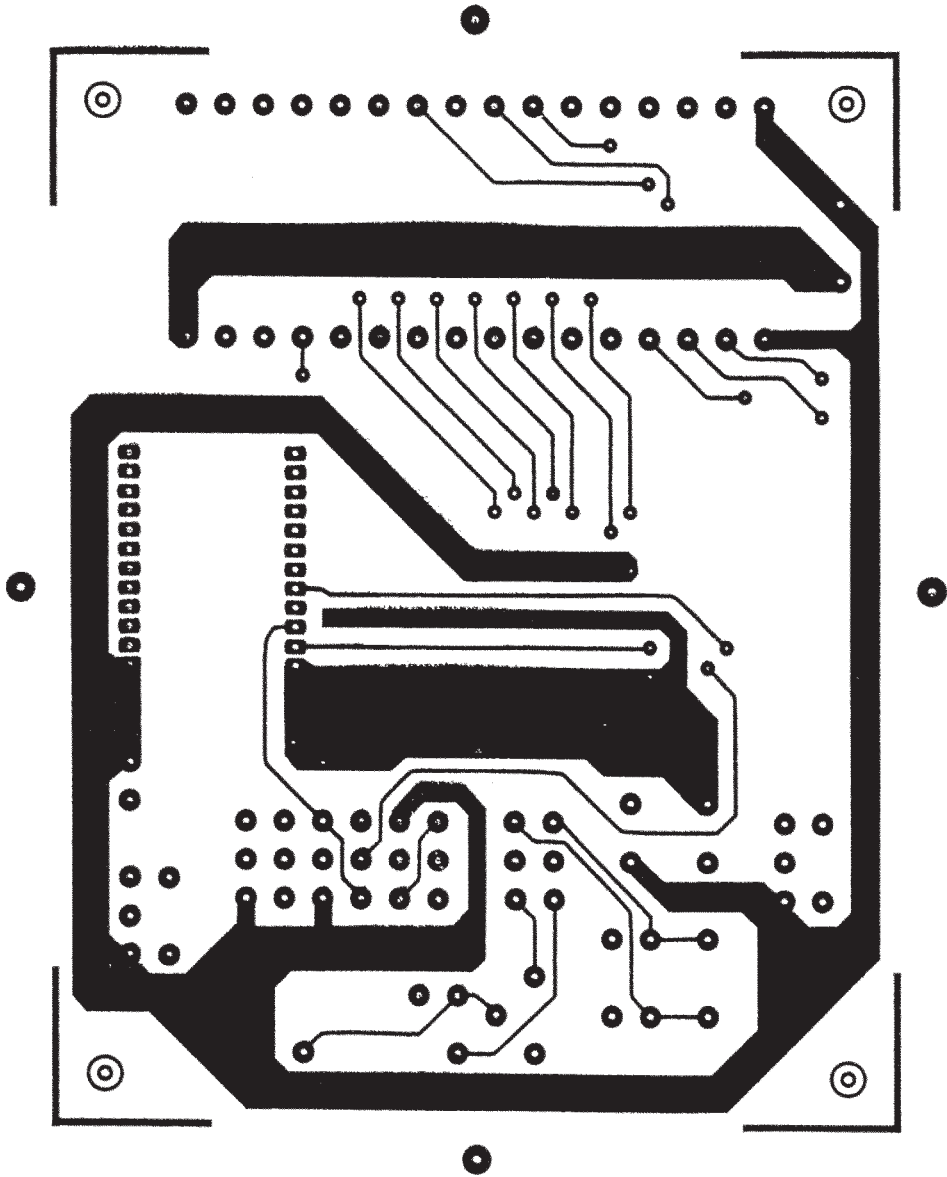

NOTICE

1. The information contained herein can change without notice owing to product and/or technical improvements. Before using the product, please make sure that the information being referred to is up-to-date.
2. The outline of action and examples for application circuits described herein have been chosen as an explanation for the standard action and performance of the product. When planning to use the product, please ensure that the external conditions are reflected in the actual circuit, assembly, and program designs.
3. When designing your product, please use our product below the specified maximum ratings and within the specified operating ranges including, but not limited to, operating voltage, power dissipation, and operating temperature.
4. Oki assumes no responsibility or liability whatsoever for any failure or unusual or unexpected operation resulting from misuse, neglect, improper installation, repair, alteration or accident, improper handling, or unusual physical or electrical stress including, but not limited to, exposure to parameters beyond the specified maximum ratings or operation outside the specified operating range.
5. Neither indemnity against nor license of a third party's industrial and intellectual property right, etc. is granted by us in connection with the use of the product and/or the information and drawings contained herein. No responsibility is assumed by us for any infringement of a third party's right which may result from the use thereof.
6. The products listed in this document are intended for use in general electronics equipment for commercial applications (e.g., office automation, communication equipment, measurement equipment, consumer electronics, etc.). These products are not authorized for use in any system or application that requires special or enhanced quality and reliability characteristics nor in any system or application where the failure of such system or application may result in the loss or damage of property, or death or injury to humans. Such applications include, but are not limited to, traffic and automotive equipment, safety devices, aerospace equipment, nuclear power control, medical equipment, and life-support systems.
7. Certain products in this document may need government approval before they can be exported to particular countries. The purchaser assumes the responsibility of determining the legality of export of these products and will take appropriate and necessary steps at their own expense for these.
8. No part of the contents contained herein may be reprinted or reproduced without our prior permission.
9. MS-DOS is a registered trademark of Microsoft Corporation.

Copyright 1999 Oki Electric Industry Co., Ltd.
