

# MSM64153A/64153AL

## 4-Bit Microcontroller with Built-in LCD Driver and Melody Circuit

### GENERAL DESCRIPTION

The MSM64153A (1.5 V)/64153AL (3.0 V) is a high-performance 4-bit microcontroller that incorporates Oki-original CPU core nX-4/20.

The MSM64153A/64153AL has an LCD driver for up to 144 segments, an event counter, and melody circuits. It is best suited for applications such as clocks and LCD games.

### FEATURES

- Operating range
  - Operating voltage : 1.5 V/3.0 V
  - Operating temperature : -40 to +70 °C
  - Operating frequency : 32.768 kHz crystal oscillation  
Approx. 32 kHz RC oscillation
  - Supply current (Typ.) : 0.9 μA (3.0 V at HALT mode)
- Minimum instruction execution time : 91 μs
- General memory space : 3040 bytes
- Local memory space : 160 nibbles
- LCD driver : 40
  - Common driver × 4
  - Segment driver × 36
  - 1/4 duty, 1/3 bias; 144 segments (36 × 4)
  - 1/3 duty, 1/3 bias; 108 segments (36 × 3)
- I/O port
  - Input-output port : 2 ports × 4 bits (open-drain output/CMOS output selectable; pull-down resistor input/high-impedance input selectable)
  - Input port : 1 port × 2 bits (pull-down resistor input/high-impedance input selectable)  
1 port × 4 bits (pull-down resistor input/high-impedance input selectable)
- Event counter : 1 channel
- Melody output : 2
- Interrupts : 10 sources
  - External 4, time base 4, melody 2
- Package:
  - 80-pin plastic QFP (QFP80-P-1420-0.80-BK) : (Product name : MSM64153A-xxxGS-BK,  
MSM64153AL-xxxGS-BK)
  - Chip : MSM64153A-xxx, MSM64153AL-xxx  
xxx indicates a code number.
- OTP version (for program evaluation) : MSM64P155/64P155L  
(The package, power polarity, and operating voltage of the MSM64P155/64P155L are different from the MSM64153A/64153AL. For details, refer to the "MSM64P155 User's Manual".)

**BLOCK DIAGRAM**

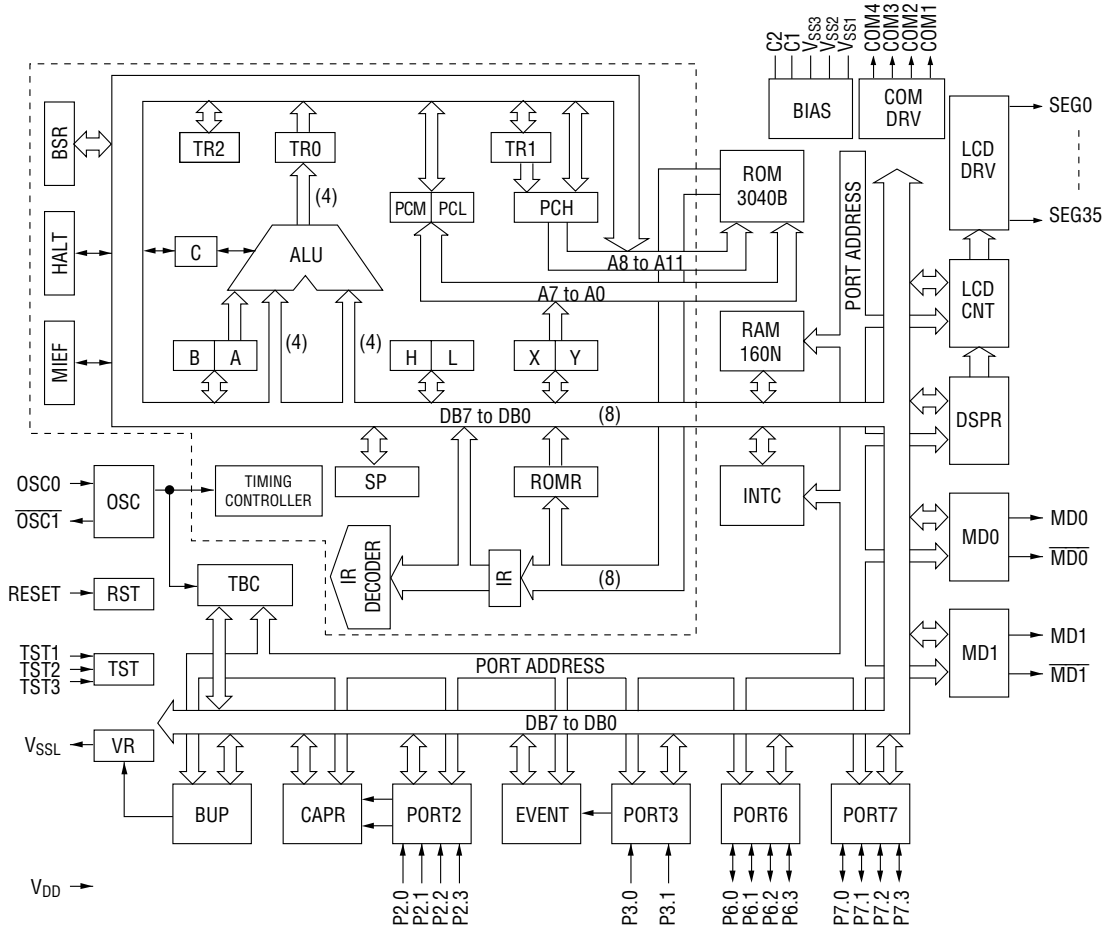

--- is the CPU core (nX-4/20).

**PIN CONFIGURATION (TOP VIEW)**

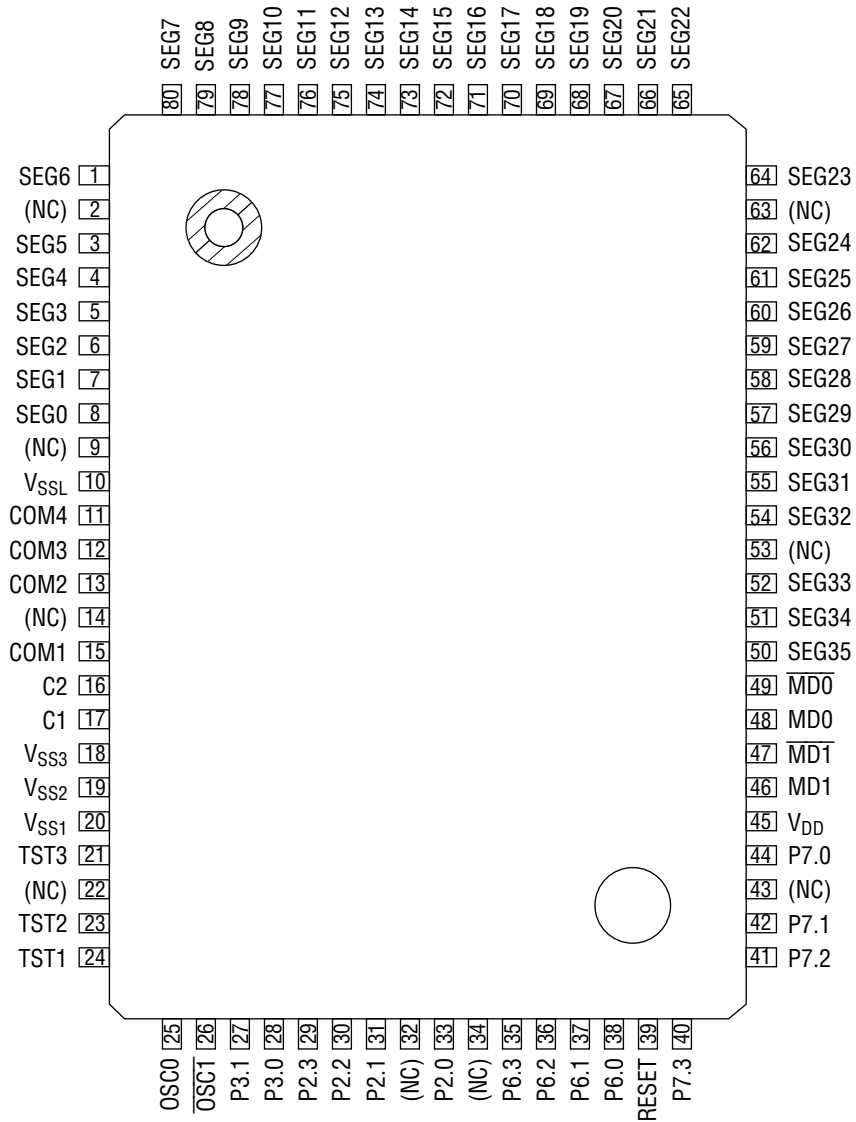

**80-Pin Plastic QFP**

Note: Pins marked as (NC) are no-connection pins which are left open.

## PAD CONFIGURATION

### Pad Layout

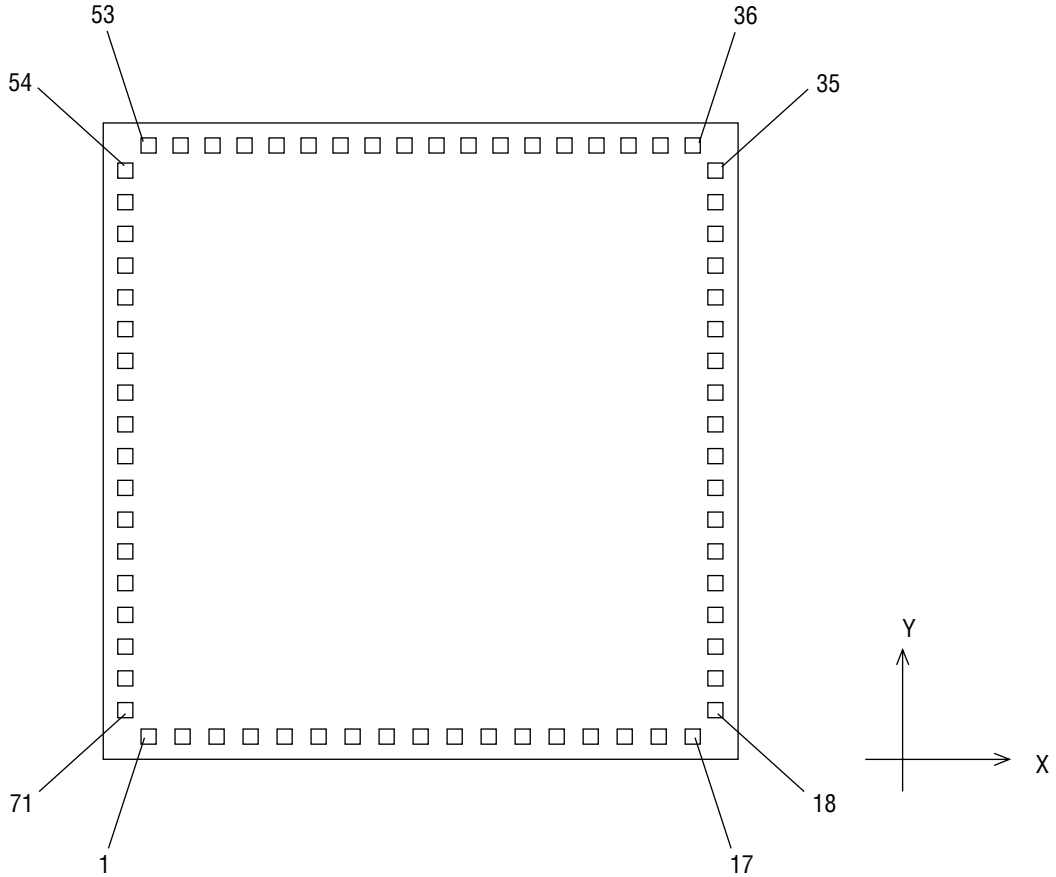

Chip Size	: 4.08 mm × 4.02 mm
Chip Thickness	: 350 μm (typ.)
Coordinate Origin	: Chip center
Pad Hole Size	: 110 μm × 110 μm
Pad Size	: 120 μm × 120 μm
Minimum Pad Pitch	: 180 μm

Note: The chip substrate voltage is  $V_{DD}$ .

## Pad Coordinates

Pad No.	Pad Name	X (μm)	Y (μm)	Pad No.	Pad Name	X (μm)	Y (μm)
1	SEG5	-1697	-1809	41	MD0	755	1809
2	SEG4	-1482	-1809	42	SEG35	547	1809
3	SEG3	-1270	-1809	43	SEG34	339	1809
4	SEG2	-1058	-1809	44	SEG33	131	1809
5	SEG1	-848	-1809	45	SEG32	-77	1809
6	SEG0	-637	-1809	46	SEG31	-284	1809
7	V <sub>SSL</sub>	-424	-1809	47	SEG30	-494	1809
8	COM4	-201	-1809	48	SEG29	-701	1809
9	COM3	10	-1809	49	SEG28	-907	1809
10	COM2	222	-1809	50	SEG27	-1116	1809
11	COM1	430	-1809	51	SEG26	-1324	1809
12	C2	641	-1809	52	SEG25	-1530	1809
13	C1	854	-1809	53	SEG24	-1743	1809
14	V <sub>SS3</sub>	1065	-1809	54	SEG23	-1889	1599
15	V <sub>SS2</sub>	1275	-1809	55	SEG22	-1889	1409
16	V <sub>SS1</sub>	1486	-1809	56	SEG21	-1889	1214
17	TST3	1697	-1809	57	SEG20	-1889	1019
18	TST2	1889	-1712	58	SEG19	-1889	829
19	TST1	1889	-1516	59	SEG18	-1889	639
20	OSC0	1889	-1319	60	SEG17	-1889	449
21	OSC1	1889	-1123	61	SEG16	-1889	260
22	P3.1	1889	-927	62	SEG15	-1889	70
23	P3.0	1889	-730	63	SEG14	-1889	-120
24	P2.3	1889	-536	64	SEG13	-1889	-310
25	P2.2	1889	-338	65	SEG12	-1889	-501
26	P2.1	1889	-141	66	SEG11	-1889	-693
27	P2.0	1889	55	67	SEG10	-1889	-885
28	P6.3	1889	251	68	SEG9	-1889	-1078
29	P6.2	1889	448	69	SEG8	-1889	-1271
30	P6.1	1889	644	70	SEG7	-1889	-1465
31	P6.0	1889	840	71	SEG6	-1889	-1656
32	RESET	1889	1036				
33	P7.3	1889	1233				
34	P7.2	1889	1429				
35	P7.1	1889	1625				
36	P7.0	1796	1809				
37	V <sub>DD</sub>	1585	1809				
38	MD1	1378	1809				
39	MD1	1172	1809				
40	MD0	962	1809				

## PIN DESCRIPTIONS

### Basic Functions

Function	Pin	Pad	Symbol	Type	Description
Power Supply	45	37	V <sub>DD</sub>	—	Digital supply voltage (0 V)
	20	16	V <sub>SS1</sub>	—	Digital negative power supply (1.5 V spec.) Bias output for LCD driver (3.0 V spec.)
	19	15	V <sub>SS2</sub>	—	Digital negative power supply (3.0 V spec.) Bias output for LCD driver (1.5 V spec.)
	18	14	V <sub>SS3</sub>	—	Bias output for LCD driver (−4.5 V)
	17	13	C1	—	For connection to capacitors that generate bias for the LCD driver
	16	12	C2	—	
	10	7	V <sub>SSL</sub>	—	Negative power supply voltage pin for internal logic (An internally generated constant voltage is present at this pin.)
Oscillation	25	20	OSCO	I	Clock oscillation pins: Either a crystal (32.768 kHz) and a capacitor (10 to 30 pF) are connected to these pins or a resistor (1 MΩ) is.
	26	21	$\overline{\text{OSCI}}$	0	
Test	24	19	TST1	I	Input pins for test
	23	18	TST2	I	
	21	17	TST3	I	
RESET	39	32	RESET	I	System reset input pin : Setting this pin to "H" level puts this device into a reset state. Then, setting this pin to "L" level starts executing an instruction from address 0000H. This pin is internally connected to V <sub>SS1</sub> or V <sub>SS2</sub> through a pull-down resistor.

## Basic Functions (continued)

Function	Pin	Pad	Symbol	Type	Description
Ports	33	27	P2.0	I	4-bit input port (port 2) : Select between pull-down resistor input and high impedance input for each bit with the port 2 control register (P2CON). When configured for secondary functions, an external interrupt and capture circuit trigger input are allocated. If P2.0 to P2.3 are set to "H" level, the device enters system reset mode.
	31	26	P2.1		
	30	25	P2.2		
	29	24	P2.3		
	28	23	P3.0	I	2-bit input port (port 3) : Select between pull-down resistor input and high impedance input with the port 3 control register (P3CON). When configured for a secondary function, an external interrupt is allocated to P3.0 and an event counter is allocated to P3.1.
	27	22	P3.1		
	38	31	P6.0	I/O	4-bit input-output port (port 6) : Select between input and output, between pull-down resistor input and high impedance input, and between open-drain output and CMOS output with the port 6 control register (P6CON). When configured for a secondary function, an external interrupt is allocated.
	37	30	P6.1		
	36	29	P6.2		
	35	28	P6.3		
	44	36	P7.0	I/O	4-bit input-output port (port 7) : Select between input and output, between pull-down resistor input and high impedance input, and between open-drain output and CMOS output with the port 7 control register (P7CON). When configured for a secondary function, an external interrupt is allocated.
	42	35	P7.1		
41	34	P7.2			
40	33	P7.3			
Melody Drivers	48	40	MD0	0	Output pin of melody driver 0
	49	41	$\overline{\text{MD0}}$	0	Inverted output pin of MD0 output
	46	38	MD1	0	Output pin of melody driver 1
	47	39	$\overline{\text{MD1}}$	0	Inverted output pin of MD1 output
LCD Drivers	15	11	COM1	0	LCD common signal output pins
	13	10	COM2	0	
	12	9	COM3	0	
	11	8	COM4	0	

**Basic Functions (continued)**

Function	Pin	Pad	Symbol	Type	Description
LCD Drivers	8	6	SEG0	0	LCD segment signal output pins
	7	5	SEG1	0	
	6	4	SEG2	0	
	5	3	SEG3	0	
	4	2	SEG4	0	
	3	1	SEG5	0	
	1	71	SEG6	0	
	80	70	SEG7	0	
	79	69	SEG8	0	
	78	68	SEG9	0	
	77	67	SEG10	0	
	76	66	SEG11	0	
	75	65	SEG12	0	
	74	64	SEG13	0	
	73	63	SEG14	0	
	72	62	SEG15	0	
	71	61	SEG16	0	
	70	60	SEG17	0	
	69	59	SEG18	0	
	68	58	SEG19	0	
	67	57	SEG20	0	
	66	56	SEG21	0	
	65	55	SEG22	0	
	64	54	SEG23	0	
	62	53	SEG24	0	
	61	52	SEG25	0	
	60	51	SEG26	0	
	59	50	SEG27	0	
	58	49	SEG28	0	
	57	48	SEG29	0	
	56	47	SEG30	0	
	55	46	SEG31	0	
	54	45	SEG32	0	
	52	44	SEG33	0	
	51	43	SEG34	0	
50	42	SEG35	0		



## Secondary Functions

Function	Pin	Pad	Symbol	Type	Description
External Interrupts	33	27	P2.0	I	P2.0 to P2.3 secondary functions : These are level-triggered external interrupt input pins. Select interrupt enable/disable for each bit with the P2 interrupt enable register (P2IE). If P2.0 to P2.3 pins are set to "H" level for a minimum of 2 seconds, the device enters system reset mode. P2.0, P2.1 secondary functions : trigger input pins for capture circuit.
	31	26	P2.1		
	30	25	P2.2		
	29	24	P2.3		
	28	23	P3.0	I	P3.0 secondary function : This is an input pin for external interrupt. This pin can receive an interrupt at a rising edge, a falling edge, or at both rising and falling edges.
	38	31	P6.0	I	P6.0 to P6.3 secondary functions : These are level-triggered external interrupt input pins.
	37	30	P6.1		
	36	29	P6.2		
	35	28	P6.3		
	Event Counter Input	44	36	P7.0	I
42		35	P7.1		
41		34	P7.2		
40		33	P7.3		
Event Counter Input	27	22	P3.1	I	P3.1 secondary function : Input port for event counter

**Handling When Specific Pins Are Not Used**

<b>Symbol</b>	<b>Recommended Pin Connection</b>
TST1 to TST3	Open
P2.0 to P2.3	"L" level or open
P3.0, P3.1	"L" level or open
P6.0 to P6.3	In input mode : "L" level or open (Initial setting: input mode) In output mode : Open
P7.0 to P7.3	In input mode : "L" level or open (Initial setting: input mode) In output mode : Open
MD0, $\overline{\text{MD0}}$ MD1, $\overline{\text{MD1}}$	Open
COM1 to COM4	Open
SEG0 to SEG35	Open

**ABSOLUTE MAXIMUM RATINGS****1.5 V Spec. (MSM64153A)**(V<sub>DD</sub> = 0 V)

Parameter	Symbol	Condition	Rating	Unit
Power Supply Voltage 1	V <sub>SS1</sub>	Ta = 25°C	-2.0 to +0.3	V
Power Supply Voltage 2	V <sub>SS2</sub>	Ta = 25°C	-4.0 to +0.3	V
Power Supply Voltage 3	V <sub>SS3</sub>	Ta = 25°C	-5.5 to +0.3	V
Power Supply Voltage 4	V <sub>SSL</sub>	Ta = 25°C	-2.0 to +0.3	V
Input Voltage 1	V <sub>IN1</sub>	V <sub>SS1</sub> input, Ta = 25°C	V <sub>SS1</sub> - 0.3 to +0.3	V
Input Voltage 2	V <sub>IN2</sub>	V <sub>SSL</sub> input, Ta = 25°C	V <sub>SSL</sub> - 0.3 to +0.3	V
Output Voltage 1	V <sub>OUT1</sub>	V <sub>SS1</sub> output, Ta = 25°C	V <sub>SS1</sub> - 0.3 to +0.3	V
Output Voltage 2	V <sub>OUT2</sub>	V <sub>SS2</sub> output, Ta = 25°C	V <sub>SS2</sub> - 0.3 to +0.3	V
Output Voltage 3	V <sub>OUT3</sub>	V <sub>SS3</sub> output, Ta = 25°C	V <sub>SS3</sub> - 0.3 to +0.3	V
Output Voltage 4	V <sub>OUT4</sub>	V <sub>SSL</sub> output, Ta = 25°C	V <sub>SSL</sub> - 0.3 to +0.3	V
Storage Temperature	T <sub>STG</sub>	—	-55 to +150	°C

**RECOMMENDED OPERATING CONDITIONS****1.5 V Spec. (MSM64153A)**(V<sub>DD</sub> = 0 V)

Parameter	Symbol	Condition	Range	Unit
Operating Temperature	T <sub>op</sub>	—	-40 to +70	°C
Operating Voltage	V <sub>SS1</sub>	BUPF = "0"	-1.7 to -1.25	V
		BUPF = "1"	-1.7 to -1.15	
Crystal Oscillation Frequency	f <sub>XT</sub>	—	30 to 35	kHz
External RC Oscillator Resistance	R <sub>OS</sub>	—	1M ±10%	Ω

## ELECTRICAL CHARACTERISTICS

## 1.5 V Spec. (MSM64153A)

## DC Characteristics

(V<sub>DD</sub> = 0 V, V<sub>SS1</sub> = -1.5 V, T<sub>a</sub> = -40 to +70°C unless otherwise specified.)

Parameter	Symbol	Condition	Min.	Typ.	Max.	Unit	Measuring Circuit
V <sub>SS2</sub> Voltage	V <sub>SS2</sub>	C <sub>a</sub> , C <sub>b</sub> , C <sub>12</sub> = 0.1 μF +100% T <sub>a</sub> = -40 to +60°C BUPF = "0"	-3.2	-3.0	-2.8	V	1 1'
		C <sub>a</sub> , C <sub>b</sub> , C <sub>12</sub> = 0.1 μF +100% T <sub>a</sub> = -40 to +70°C BUPF = "0"	-3.2	-3.0	-2.7		
		C <sub>a</sub> , C <sub>b</sub> , C <sub>12</sub> = 0.1 μF +100% T <sub>a</sub> = -40 to +60°C BUPF = "1"	-3.2	-3.0	-2.5		
		C <sub>a</sub> , C <sub>b</sub> , C <sub>12</sub> = 0.2 μF +100% T <sub>a</sub> = -40 to +70°C BUPF = "1"	-3.2	-3.0	-2.3		
V <sub>SS3</sub> Voltage	V <sub>SS3</sub>	C <sub>a</sub> , C <sub>b</sub> , C <sub>12</sub> = 0.1 μF +100% T <sub>a</sub> = -40 to +60°C BUPF = "0"	-4.7	-4.5	-4.2	V	1 1'
		C <sub>a</sub> , C <sub>b</sub> , C <sub>12</sub> = 0.1 μF +100% T <sub>a</sub> = -40 to +70°C BUPF = "0"	-4.7	-4.5	-4.0		
		C <sub>a</sub> , C <sub>b</sub> , C <sub>12</sub> = 0.1 μF +100% T <sub>a</sub> = -40 to +60°C BUPF = "1"	-4.7	-4.5	-3.9		
		C <sub>a</sub> , C <sub>b</sub> , C <sub>12</sub> = 0.2 μF +100% T <sub>a</sub> = -40 to +70°C BUPF = "1"	-4.7	-4.5	-3.7		
V <sub>SSL</sub> Voltage	V <sub>SSL</sub>	BUPF = "0"	-1.5	-1.3	-0.6	V	
		BUPF = "1"	-1.9	-1.3	-0.6		
Crystal Oscillation Start Voltage	V <sub>STA</sub>	Oscillation start time: within 5 seconds after reset	—	—	-1.45	V	1
Crystal Oscillation Hold Voltage	V <sub>HOLD</sub>	—	—	—	-1.15	V	
External Crystal Oscillator Capacitance	C <sub>G</sub>	—	10	—	30	pF	
Internal Crystal Oscillator Capacitance	C <sub>D</sub>	—	10	15	20	pF	
RC Oscillation Frequency	f <sub>CR</sub>	R <sub>OS</sub> = 1 MΩ	15	40	75	kHz	1'

**DC Characteristics (continued)**

- 32.768 kHz crystal oscillation

(V<sub>DD</sub> = 0 V, V<sub>SS1</sub> = -1.5 V, Ta = -40 to +70°C unless otherwise specified.)

Parameter	Symbol	Condition		Min.	Typ.	Max.	Unit	Measuring Circuit
Supply Current 1	I <sub>DD1</sub>	CPU is in HALT state BUPF = "0"	Ta = -40 to +40°C	—	2.0	6.0	μA	1
			Ta = +40 to +70°C	—	2.0	40	μA	
Supply Current 1	I <sub>DD1</sub>	CPU is in HALT state BUPF = "1"	Ta = -40 to +40°C	—	3.0	10	μA	
			Ta = +40 to +70°C	—	3.0	50	μA	
Supply Current 2	I <sub>DD2</sub>	CPU is in operation state BUPF = "0"	Ta = -40 to +40°C	—	6.0	15	μA	
			Ta = +40 to +70°C	—	6.0	50	μA	
Supply Current 2	I <sub>DD2</sub>	CPU is in operation state BUPF = "1"	Ta = -40 to +40°C	—	10	25	μA	
			Ta = +40 to +70°C	—	10	60	μA	

- RC oscillation

(V<sub>DD</sub> = 0 V, V<sub>SS1</sub> = -1.5 V, R<sub>OS</sub> = 1 MΩ, Ta = -40 to +70°C unless otherwise specified.)

Parameter	Symbol	Condition		Min.	Typ.	Max.	Unit	Measuring Circuit
Supply Current 1	I <sub>DD1</sub>	CPU is in HALT state BUPF = "0"	Ta = -40 to +40°C	—	3.0	10	μA	1'
			Ta = +40 to +70°C	—	3.0	45	μA	
Supply Current 1	I <sub>DD1</sub>	CPU is in HALT state BUPF = "1"	Ta = -40 to +40°C	—	6.0	15	μA	
			Ta = +40 to +70°C	—	6.0	50	μA	
Supply Current 2	I <sub>DD2</sub>	CPU is in operation state BUPF = "0"	Ta = -40 to +40°C	—	7.0	20	μA	
			Ta = +40 to +70°C	—	7.0	50	μA	
Supply Current 2	I <sub>DD2</sub>	CPU is in operation state BUPF = "1"	Ta = -40 to +40°C	—	15	30	μA	
			Ta = +40 to +70°C	—	15	70	μA	

## DC Characteristics (continued)

(V<sub>DD</sub> = 0 V, V<sub>SS1</sub> = V<sub>SSL</sub> = -1.5 V, V<sub>SS2</sub> = -3.0 V, V<sub>SS3</sub> = -4.5 V, T<sub>a</sub> = -40 to +70°C unless otherwise specified.)

Parameter (Pin Name)	Symbol	Condition	Min.	Typ.	Max.	Unit	Measuring Circuit	
Output Current 1 (MD0, MD0) (MD1, MD1)	I <sub>OH1</sub>	V <sub>OH1</sub> = -0.5 V	-2.0	-0.6	-0.1	mA	2	
	I <sub>OL1</sub>	V <sub>OL1</sub> = V <sub>SS1</sub> + 0.5 V	0.1	0.6	2.0	mA		
Output Current 2 (SEG0 to SEG35) (COM1 to COM4)	I <sub>OH2</sub>	V <sub>OH2</sub> = -0.2 V (V <sub>DD</sub> level)	—	—	-4.0	μA		
	I <sub>OMH2</sub>	V <sub>OMH2</sub> = V <sub>SS1</sub> + 0.2 V (V <sub>SS1</sub> level)	4.0	—	—	μA		
	I <sub>OMH2S</sub>	V <sub>OMH2S</sub> = V <sub>SS1</sub> - 0.2 V (V <sub>SS1</sub> level)	—	—	-4.0	μA		
	I <sub>OML2</sub>	V <sub>OML2</sub> = V <sub>SS2</sub> + 0.2 V (V <sub>SS2</sub> level)	4.0	—	—	μA		
	I <sub>OML2S</sub>	V <sub>OML2S</sub> = V <sub>SS2</sub> - 0.2 V (V <sub>SS2</sub> level)	—	—	-4.0	μA		
	I <sub>OL2</sub>	V <sub>OL2</sub> = V <sub>SS3</sub> + 0.2 V (V <sub>SS3</sub> level)	4.0	—	—	μA		
Output Current 3 (P6.0 to P6.3) (P7.0 to P7.3)	I <sub>OH3</sub>	V <sub>OH3</sub> = -0.5 V	-5.0	-2.1	-0.3	mA		
	I <sub>OL3</sub>	V <sub>OL3</sub> = V <sub>SS1</sub> + 0.5 V	0.1	0.7	2.0	mA		
Output Leakage Current (P6.0 to P6.3) (P7.0 to P7.3)	I <sub>OOH</sub>	V <sub>OH</sub> = V <sub>DD</sub>	—	—	0.3	μA		
	I <sub>OOL</sub>	V <sub>OL</sub> = V <sub>SS1</sub>	-0.3	—	—	μA		
Input Current 1 (P2.0 to P2.3) (P3.0, P3.1) (P6.0 to P6.3) (P7.0 to P7.3)	I <sub>IH1</sub>	V <sub>IH1</sub> = V <sub>DD</sub> (When pulled down)	1.0	20	100	μA		3
	I <sub>IH1Z</sub>	V <sub>IH1</sub> = V <sub>DD</sub> (In a high-impedance state)	0	—	1.0	μA		
	I <sub>IL1</sub>	V <sub>IL1</sub> = V <sub>SS1</sub>	-1.0	—	0	μA		
Input Current 2 (TST1, TST2, TST3)	I <sub>IH2</sub>	V <sub>IH2</sub> = V <sub>DD</sub>	0.3	0.75	1.5	mA		
	I <sub>IL2</sub>	V <sub>IL2</sub> = V <sub>SS1</sub>	-1.0	—	0	μA		
Input Current 3 (RESET)	I <sub>IH3</sub>	V <sub>IH3</sub> = V <sub>DD</sub>	15	40	100	μA		
	I <sub>IL3</sub>	V <sub>IL3</sub> = V <sub>SS1</sub>	-1.0	—	0	μA		
Input Voltage 1 (P2.0 to P2.3) (P3.0, P3.1) (P6.0 to P6.3) (TST1, TST2, TST3) (RESET)	V <sub>IH1</sub>	—	-0.3	—	0	V	4	
	V <sub>IL1</sub>	—	-1.5	—	-1.2	V		

**Measuring circuit 1**

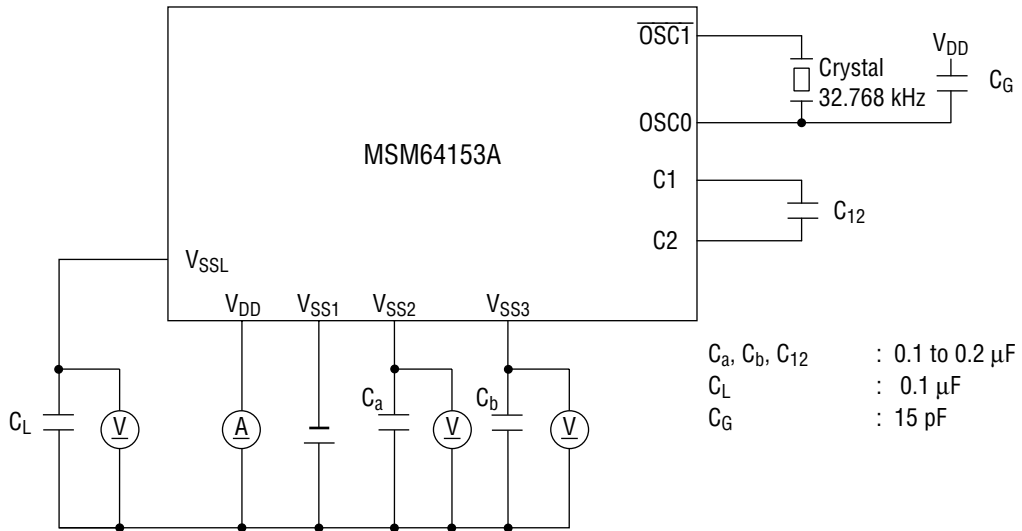

**Measuring circuit 1'**

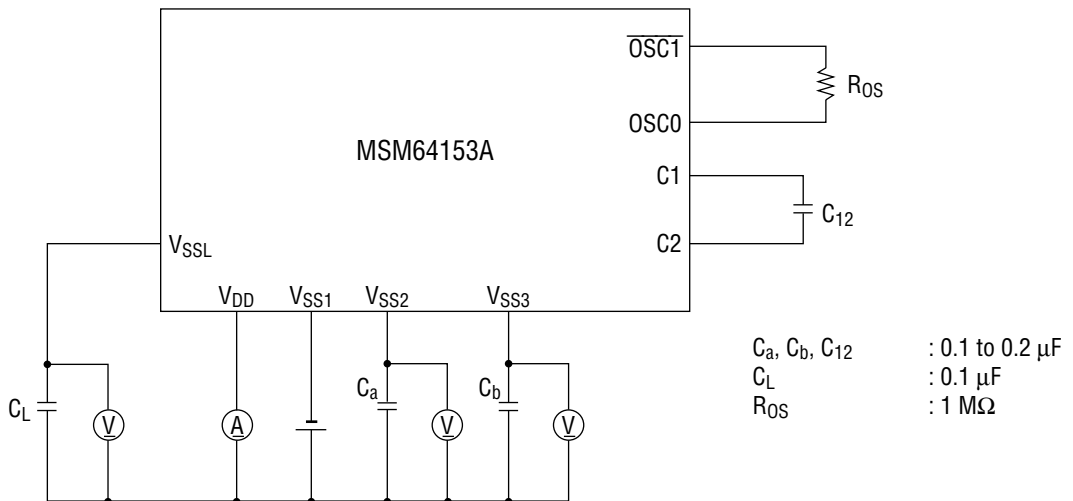

### Measuring circuit 2

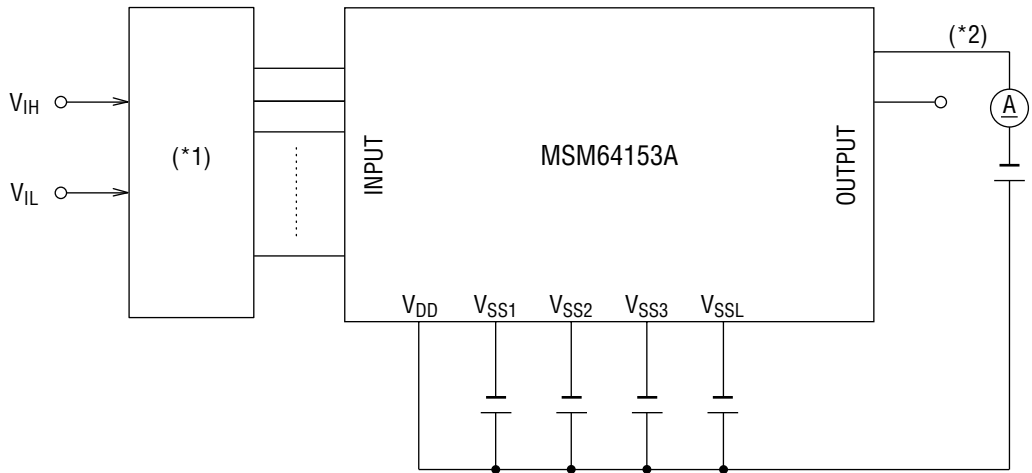

### Measuring circuit 3

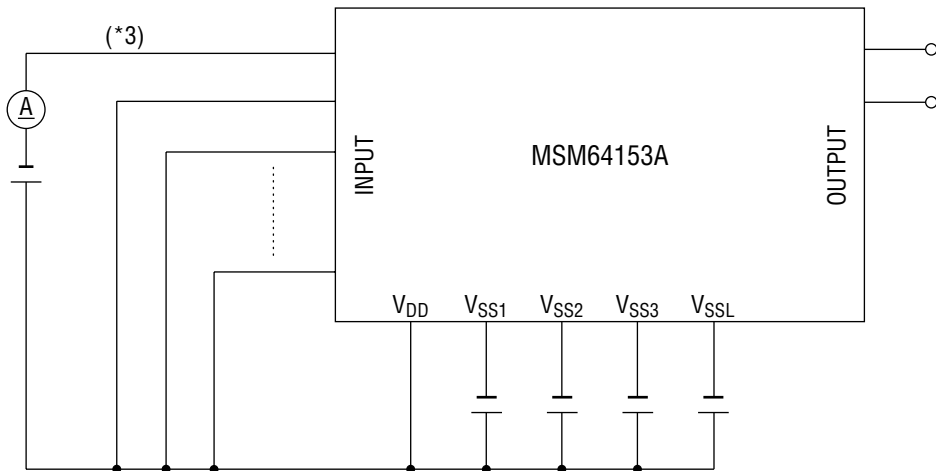



**Measuring circuit 4**

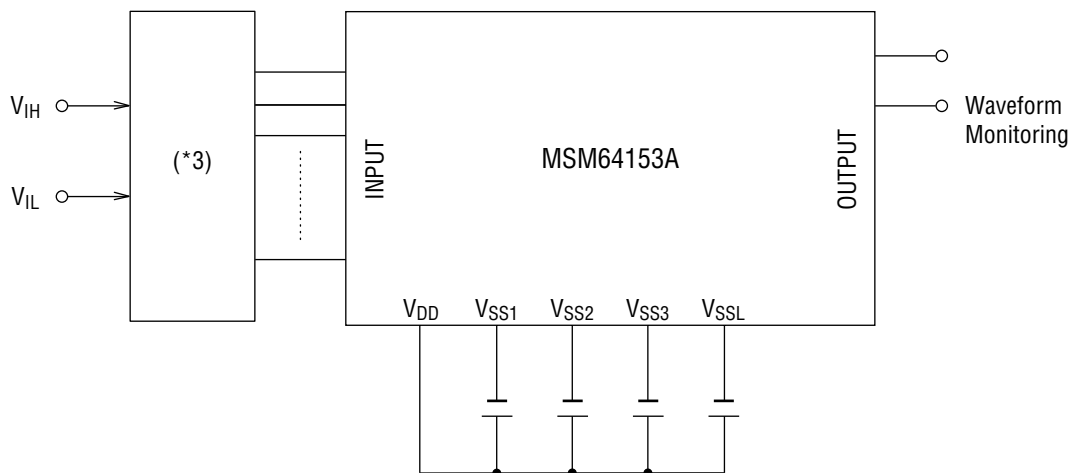

\*1 Input logic circuit to determine the specified measuring conditions.

\*2 Measured at the specified output pins.

\*3 Measured at the specified input pins.

**ABSOLUTE MAXIMUM RATINGS****3.0 V Spec. (MSM64153AL)**(V<sub>DD</sub> = 0 V)

Parameter	Symbol	Condition	Rating	Unit
Power Supply Voltage 1	V <sub>SS1</sub>	Ta = 25°C	-2.0 to +0.3	V
Power Supply Voltage 2	V <sub>SS2</sub>	Ta = 25°C	-4.0 to +0.3	V
Power Supply Voltage 3	V <sub>SS3</sub>	Ta = 25°C	-5.5 to +0.3	V
Power Supply Voltage 4	V <sub>SSL</sub>	Ta = 25°C	-4.0 to +0.3	V
Input Voltage 1	V <sub>IN1</sub>	V <sub>SS2</sub> input, Ta = 25°C	V <sub>SS2</sub> - 0.3 to +0.3	V
Input Voltage 2	V <sub>IN2</sub>	V <sub>SSL</sub> input, Ta = 25°C	V <sub>SSL</sub> - 0.3 to +0.3	V
Output Voltage 1	V <sub>OUT1</sub>	V <sub>SS2</sub> output, Ta = 25°C	V <sub>SS2</sub> - 0.3 to +0.3	V
Output Voltage 2	V <sub>OUT2</sub>	V <sub>SS3</sub> output, Ta = 25°C	V <sub>SS3</sub> - 0.3 to +0.3	V
Output Voltage 3	V <sub>OUT3</sub>	V <sub>SSL</sub> output, Ta = 25°C	V <sub>SSL</sub> - 0.3 to +0.3	V
Storage Temperature	T <sub>STG</sub>	—	-55 to +150	°C

**RECOMMENDED OPERATING CONDITIONS****3.0 V Spec. (MSM64153AL)**(V<sub>DD</sub> = 0 V)

Parameter	Symbol	Condition	Range	Unit
Operating Temperature	T <sub>op</sub>	—	-40 to +70	°C
Operating Voltage	V <sub>SS2</sub>	BUPF = "0"	-3.5 to -2.5	V
		BUPF = "1"	-3.5 to -2.0	
Crystal Oscillation Frequency	f <sub>XT</sub>	—	30 to 66	kHz
External RC Oscillator Resistance	R <sub>OS</sub>	—	1 M ±10%	Ω

**ELECTRICAL CHARACTERISTICS****3.0 V Spec. (MSM64153AL)****DC Characteristics**(V<sub>DD</sub> = 0 V, V<sub>SS2</sub> = -3.0 V, T<sub>a</sub> = -40 to +70°C unless otherwise specified.)

Parameter	Symbol	Condition	Min.	Typ.	Max.	Unit	Measuring Circuit
V <sub>SS1</sub> Voltage	V <sub>SS1</sub>	C <sub>a</sub> , C <sub>b</sub> , C <sub>12</sub> = 0.1 μF $\begin{matrix} +100\% \\ -20\% \end{matrix}$	-1.7	-1.5	-1.3	V	1 1'
V <sub>SS3</sub> Voltage	V <sub>SS3</sub>	C <sub>a</sub> , C <sub>b</sub> , C <sub>12</sub> = 0.1 μF $\begin{matrix} +100\% \\ -20\% \end{matrix}$	-4.7	-4.5	-4.2	V	
V <sub>SSL</sub> Voltage	V <sub>SSL</sub>	BUPF = "0"	-1.5	-1.3	-0.6	V	
		BUPF = "1"	-1.9	-1.3	-0.6		
Crystal Oscillation Start Voltage	V <sub>STA</sub>	Oscillation start time: within 5 seconds after reset	—	—	-2.5	V	1
Crystal Oscillation Hold Voltage	V <sub>HOLD</sub>	—	—	—	-2.0	V	
External Crystal Oscillator Capacitance	C <sub>G</sub>	—	10	—	30	pF	
Internal Crystal Oscillator Capacitance	C <sub>D</sub>	—	10	15	20	pF	
RC Oscillation Frequency	f <sub>CR</sub>	R <sub>OS</sub> = 1 MΩ	15	40	75	kHz	1'

**DC Characteristics (continued)**

- 32.768 kHz crystal oscillation

(V<sub>DD</sub> = 0 V, V<sub>SS2</sub> = -3.0 V, T<sub>a</sub> = -40 to +70°C unless otherwise specified.)

Parameter	Symbol	Condition	Min.	Typ.	Max.	Unit	Measuring Circuit	
Supply Current 1	I <sub>DD1</sub>	CPU is in HALT state BUPF = "0"	T <sub>a</sub> = -40 to +40°C	—	0.9	4.5	μA	1
			T <sub>a</sub> = +40 to +70°C	—	0.9	30	μA	
Supply Current 1	I <sub>DD1</sub>	CPU is in HALT state BUPF = "1"	T <sub>a</sub> = -40 to +40°C	—	1.5	6.0	μA	
			T <sub>a</sub> = +40 to +70°C	—	1.5	40	μA	
Supply Current 2	I <sub>DD2</sub>	CPU is in operation state BUPF = "0"	T <sub>a</sub> = -40 to +40°C	—	3.0	10	μA	
			T <sub>a</sub> = +40 to +70°C	—	3.0	40	μA	
Supply Current 2	I <sub>DD2</sub>	CPU is in operation state BUPF = "1"	T <sub>a</sub> = -40 to +40°C	—	5.0	15	μA	
			T <sub>a</sub> = +40 to +70°C	—	5.0	50	μA	

- RC oscillation

(V<sub>DD</sub> = 0 V, V<sub>SS2</sub> = -3.0 V, R<sub>OS</sub> = 1 MΩ, T<sub>a</sub> = -40 to +70°C unless otherwise specified.)

Parameter	Symbol	Condition	Min.	Typ.	Max.	Unit	Measuring Circuit	
Supply Current 1	I <sub>DD1</sub>	CPU is in HALT state BUPF = "0"	T <sub>a</sub> = -40 to +40°C	—	1.5	6.0	μA	1'
			T <sub>a</sub> = +40 to +70°C	—	1.5	40	μA	
Supply Current 1	I <sub>DD1</sub>	CPU is in HALT state BUPF = "1"	T <sub>a</sub> = -40 to +40°C	—	3.0	10	μA	
			T <sub>a</sub> = +40 to +70°C	—	3.0	50	μA	
Supply Current 2	I <sub>DD2</sub>	CPU is in operation state BUPF = "0"	T <sub>a</sub> = -40 to +40°C	—	4.0	12	μA	
			T <sub>a</sub> = +40 to +70°C	—	4.0	50	μA	
Supply Current 2	I <sub>DD2</sub>	CPU is in operation state BUPF = "1"	T <sub>a</sub> = -40 to +40°C	—	8.0	25	μA	
			T <sub>a</sub> = +40 to +70°C	—	8.0	60	μA	

**DC Characteristics (continued)**(V<sub>DD</sub> = 0 V, V<sub>SS1</sub> = V<sub>SSL</sub> = -1.5 V, V<sub>SS2</sub> = -3.0 V, V<sub>SS3</sub> = -4.5 V, T<sub>a</sub> = -40 to +70°C unless otherwise specified.)

Parameter (Pin Name)	Symbol	Condition	Min.	Typ.	Max.	Unit	Measuring Circuit
Output Current 1 (MD0, MD0) (MD1, MD1)	I <sub>OH1</sub>	V <sub>OH1</sub> = -0.5 V	-6.0	-1.8	-0.7	mA	2
	I <sub>OL1</sub>	V <sub>OL1</sub> = V <sub>SS2</sub> + 0.5 V	0.7	1.8	6.0	mA	
Output Current 2 (SEG0 to SEG35) (COM1 to COM4)	I <sub>OH2</sub>	V <sub>OH2</sub> = -0.2 V (V <sub>DD</sub> level)	—	—	-4.0	μA	
	I <sub>OMH2</sub>	V <sub>OMH2</sub> = V <sub>SS1</sub> + 0.2 V (V <sub>SS1</sub> level)	4.0	—	—	μA	
	I <sub>OMH2S</sub>	V <sub>OMH2S</sub> = V <sub>SS1</sub> - 0.2 V (V <sub>SS1</sub> level)	—	—	-4.0	μA	
	I <sub>OML2</sub>	V <sub>OML2</sub> = V <sub>SS2</sub> + 0.2 V (V <sub>SS2</sub> level)	4.0	—	—	μA	
	I <sub>OML2S</sub>	V <sub>OML2S</sub> = V <sub>SS2</sub> - 0.2 V (V <sub>SS2</sub> level)	—	—	-4.0	μA	
	I <sub>OL2</sub>	V <sub>OL2</sub> = V <sub>SS3</sub> + 0.2 V (V <sub>SS3</sub> level)	4.0	—	—	μA	
Output Current 3 (P6.0 to P6.3) (P7.0 to P7.3)	I <sub>OH3</sub>	V <sub>OH3</sub> = -0.5 V	-18	-6.0	-2.0	mA	
	I <sub>OL3</sub>	V <sub>OL3</sub> = V <sub>SS2</sub> + 0.5 V	0.7	1.6	6.0	mA	
Output Leakage Current (P6.0 to P6.3) (P7.0 to P7.3)	I <sub>OOH</sub>	V <sub>OH</sub> = V <sub>DD</sub>	—	—	0.3	μA	
	I <sub>OOL</sub>	V <sub>OL</sub> = V <sub>SS2</sub>	-0.3	—	—	μA	
Input Current 1 (P2.0 to P2.3) (P3.0, P3.1) (P6.0 to P6.3) (P7.0 to P7.3)	I <sub>IH1</sub>	V <sub>IH1</sub> = V <sub>DD</sub> (When pulled down)	50	100	300	μA	3
	I <sub>IH1Z</sub>	V <sub>IH1</sub> = V <sub>DD</sub> (In a high-impedance state)	0	—	1.0	μA	
	I <sub>IL1</sub>	V <sub>IL1</sub> = V <sub>SS2</sub>	-1.0	—	0	μA	
Input Current 2 (TST1, TST2, TST3)	I <sub>IH2</sub>	V <sub>IH2</sub> = V <sub>DD</sub>	0.75	1.5	3.0	mA	
	I <sub>IL2</sub>	V <sub>IL2</sub> = V <sub>SS2</sub>	-1.0	—	0	μA	
Input Current 3 (RESET)	I <sub>IH3</sub>	V <sub>IH3</sub> = V <sub>DD</sub>	40	80	200	μA	
	I <sub>IL3</sub>	V <sub>IL3</sub> = V <sub>SS2</sub>	-1.0	—	0	μA	
Input Voltage 3 (P2.0 to P2.3) (P3.0, P3.1) (P6.0 to P6.3) (TST1, TST2, TST3) (RESET)	V <sub>IH1</sub>	—	-0.6	—	0	V	4
	V <sub>IL1</sub>	—	-3.0	—	-2.4	V	

**Measuring circuit 1**

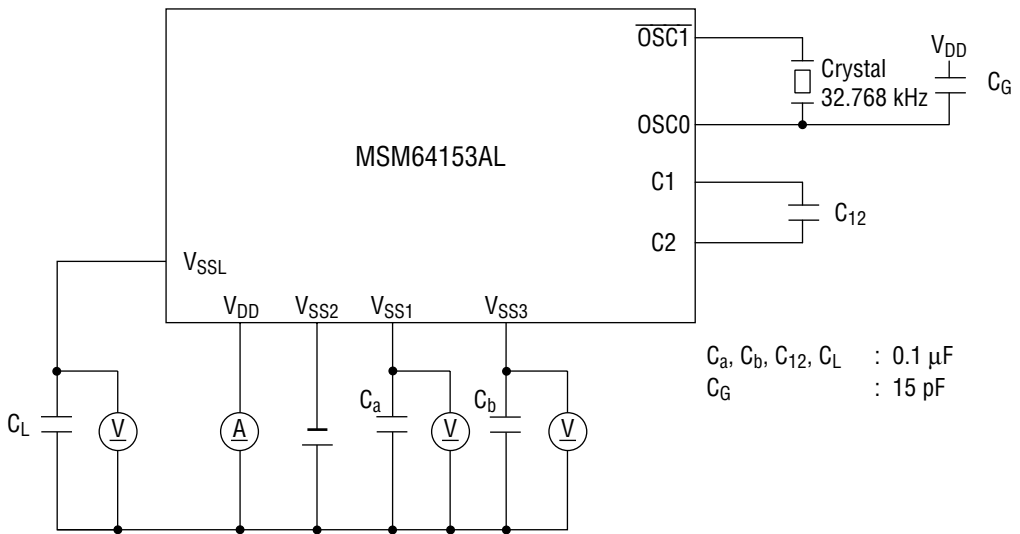

**Measuring circuit 1'**

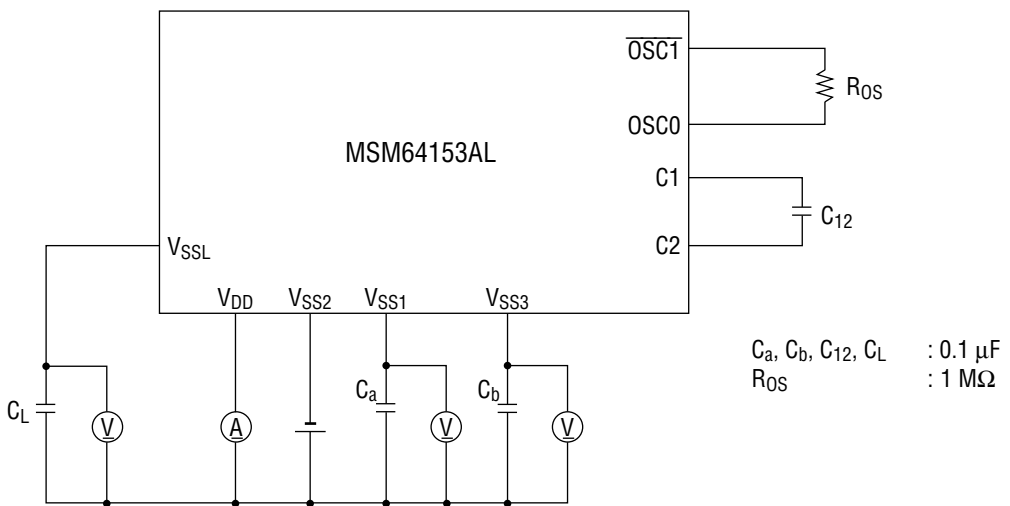

### Measuring circuit 2

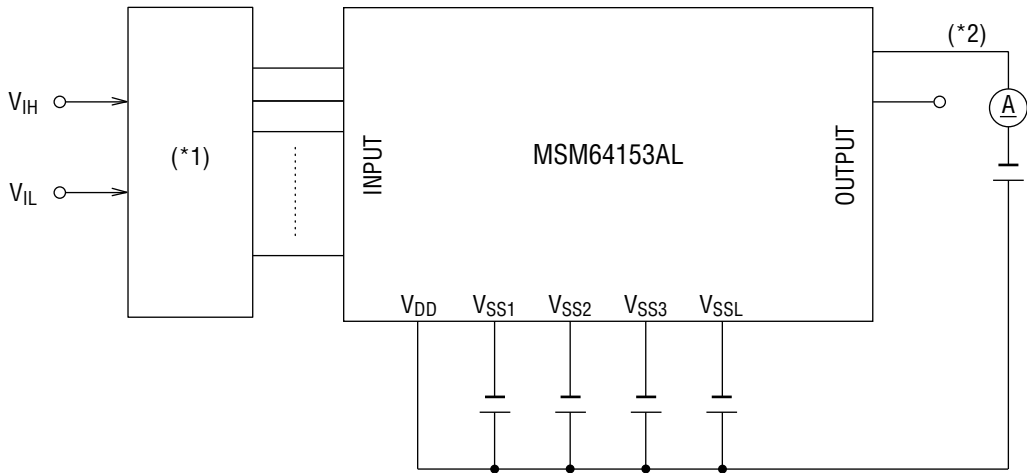

### Measuring circuit 3

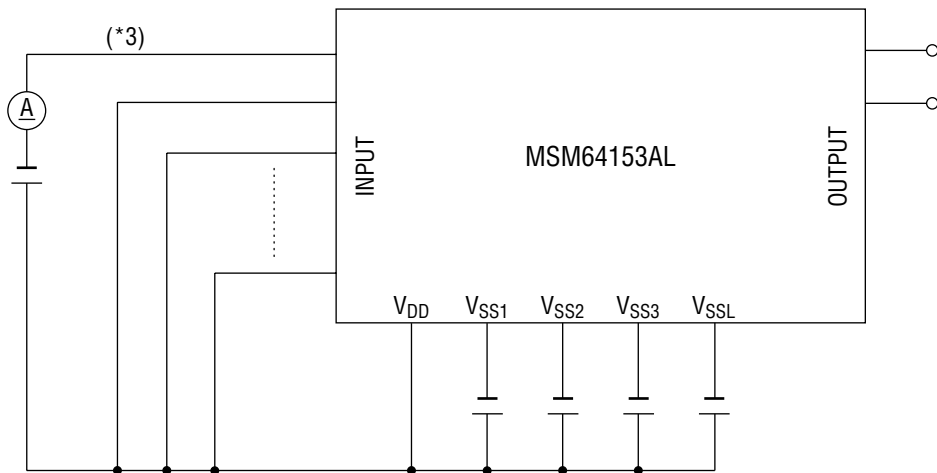

### Measuring circuit 4

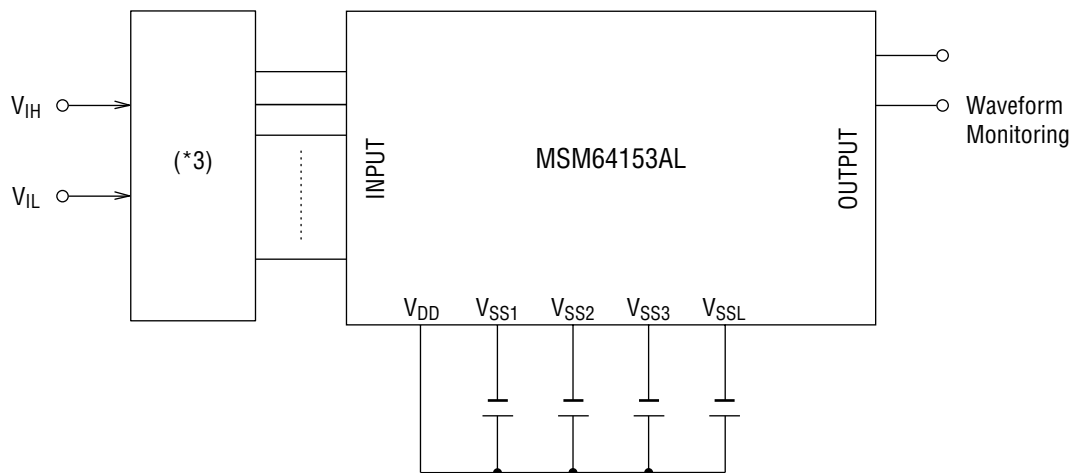

\*1 Input logic circuit to determine the specified measuring conditions.

\*2 Measured at the specified output pins.

\*3 Measured at the specified input pins.



**PACKAGE DIMENSIONS**

(Unit : mm)

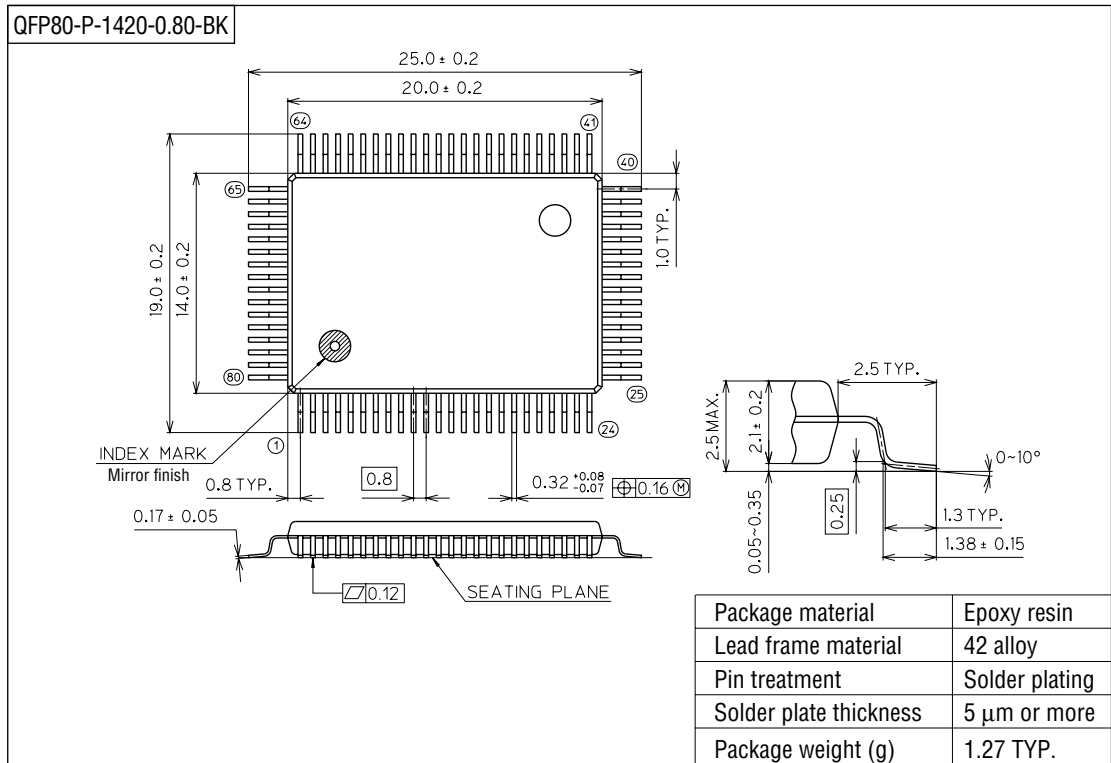

**Notes for Mounting the Surface Mount Type Package**

The SOP, QFP, TSOP, SOJ, QFJ (PLCC), SHP and BGA are surface mount type packages, which are very susceptible to heat in reflow mounting and humidity absorbed in storage. Therefore, before you perform reflow mounting, contact Oki's responsible sales person for the product name, package name, pin number, package code and desired mounting conditions (reflow method, temperature and times).