

MSM514256C/CL**262,144-Word × 4-Bit DYNAMIC RAM : FAST PAGE MODE TYPE****DESCRIPTION**

The MSM514256C/CL is a 262,144-word × 4-bit dynamic RAM fabricated in Oki's silicon-gate CMOS technology. The MSM514256C/CL achieves high integration, high-speed operation, and low-power consumption because Oki manufactures the device in a quadruple-layer polysilicon/single-layer metal CMOS process. The MSM514256C/CL is available in a 20-pin plastic DIP, 26/20-pin plastic SOJ, or 20-pin plastic ZIP. The MSM514256CL (the low-power version) is specially designed for lower-power applications.

FEATURES

- 262,144-word × 4-bit configuration
 - Single 5 V power supply, ±10% tolerance
 - Input : TTL compatible, low input capacitance
 - Output : TTL compatible, 3-state
 - Refresh : 512 cycles/8 ms, 512 cycles/64 ms (L-version)
 - Fast page mode, read modify write capability
 - $\overline{\text{CAS}}$ before $\overline{\text{RAS}}$ refresh, hidden refresh, $\overline{\text{RAS}}$ -only refresh capability
 - Package options:
 - 20-pin 300 mil plastic DIP (DIP20-P-300-2.54-W1) (Product : MSM514256C/CL-xxRS)
 - 26/20-pin 300 mil plastic SOJ (SOJ26/20-P-300-1.27) (Product : MSM514256C/CL-xxJS)
 - 20-pin 400 mil plastic ZIP (ZIP20-P-400-1.27) (Product : MSM514256C/CL-xxZS)
- xx indicates speed rank.

PRODUCT FAMILY

Family	Access Time (Max.)				Cycle Time (Min.)	Power Dissipation	
	t _{RAC}	t _{AA}	t _{CAC}	t _{OEA}		Operating (Max.)	Standby (Max.)
MSM514256C/CL-45	45 ns	24 ns	14 ns	14 ns	90 ns	468 mW	
MSM514256C/CL-50	50 ns	26 ns	14 ns	14 ns	100 ns	446 mW	5.5 mW/
MSM514256C/CL-60	60 ns	30 ns	15 ns	15 ns	120 ns	385 mW	1.1 mW (L-version)
MSM514256C/CL-70	70 ns	35 ns	20 ns	20 ns	130 ns	330 mW	

PIN CONFIGURATION (TOP VIEW)

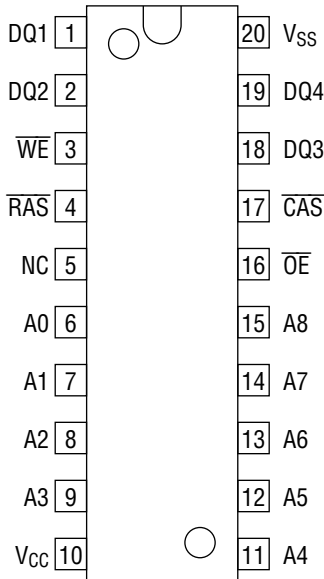

20-Pin Plastic DIP

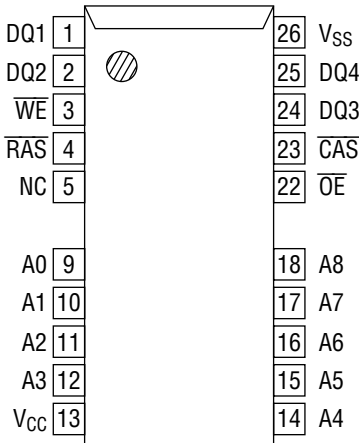

26/20-Pin Plastic SOJ

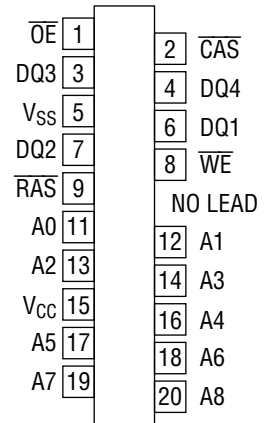

20-Pin Plastic ZIP

Pin Name	Function
A0 - A8	Address Input
$\overline{\text{RAS}}$	Row Address Strobe
$\overline{\text{CAS}}$	Column Address Strobe
DQ1 - DQ4	Data Input/Data Output
$\overline{\text{OE}}$	Output Enable
$\overline{\text{WE}}$	Write Enable
V _{CC}	Power Supply (5 V)
V _{SS}	Ground (0 V)
NC	No Connection

BLOCK DIAGRAM

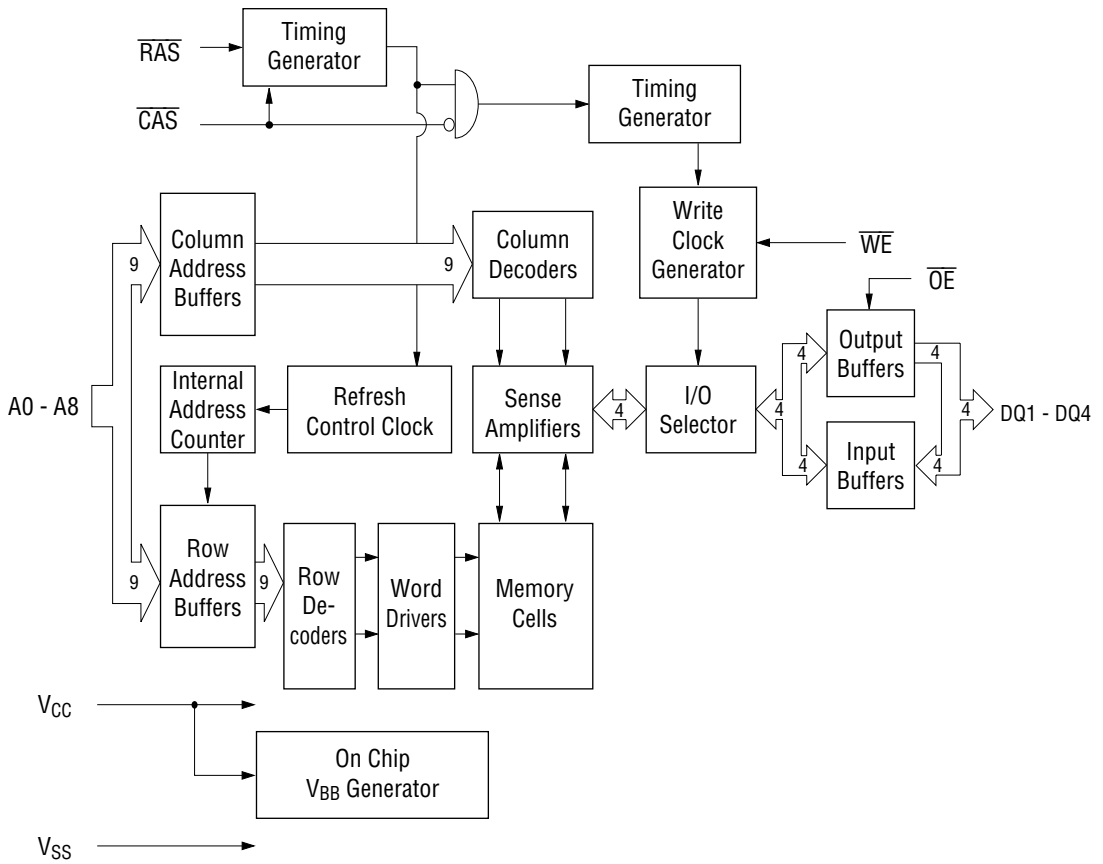

ELECTRICAL CHARACTERISTICS**Absolute Maximum Ratings**

Parameter	Symbol	Rating	Unit
Voltage on Any Pin Relative to V _{SS}	V _T	-1.0 to 7.0	V
Short Circuit Output Current	I _{OS}	50	mA
Power Dissipation	P _D *	1	W
Operating Temperature	T _{opr}	0 to 70	°C
Storage Temperature	T _{stg}	-55 to 150	°C

*: Ta = 25°C

Recommended Operating Conditions

(Ta = 0°C to 70°C)

Parameter	Symbol	Min.	Typ.	Max.	Unit
Power Supply Voltage	V _{CC}	4.5	5.0	5.5	V
	V _{SS}	0	0	0	V
Input High Voltage	V _{IH}	2.4	—	6.5	V
Input Low Voltage	V _{IL}	-1.0	—	0.8	V

Capacitance(V_{CC} = 5 V ±10%, Ta = 25°C, f = 1 MHz)

Parameter	Symbol	Typ.	Max.	Unit
Input Capacitance (A0 - A8)	C _{IN1}	—	5	pF
Input Capacitance ($\overline{\text{RAS}}$, $\overline{\text{CAS}}$, $\overline{\text{WE}}$, $\overline{\text{OE}}$)	C _{IN2}	—	5	pF
Output Capacitance (DQ1 - DQ4)	C _{I/O}	—	6	pF

DC Characteristics

(V_{CC} = 5 V ±10%, T_a = 0°C to 70°C)

Parameter	Symbol	Condition	MSM514256 C/CL-45		MSM514256 C/CL-50		MSM514256 C/CL-60		MSM514256 C/CL-70		Unit	Note
			Min.	Max.	Min.	Max.	Min.	Max.	Min.	Max.		
			Output High Voltage	V _{OH}	I _{OH} = -5.0 mA	2.4	V _{CC}	2.4	V _{CC}	2.4		
Output Low Voltage	V _{OL}	I _{OL} = 4.2 mA	0	0.4	0	0.4	0	0.4	0	0.4	V	
Input Leakage Current	I _{LI}	0 V ≤ V _I ≤ 6.5 V; All other pins not under test = 0 V	-10	10	-10	10	-10	10	-10	10	μA	
Output Leakage Current	I _{LO}	DQ disable 0 V ≤ V _O ≤ 5.5 V	-10	10	-10	10	-10	10	-10	10	μA	
Average Power Supply Current (Operating)	I _{CC1}	$\overline{\text{RAS}}$, $\overline{\text{CAS}}$ cycling, t _{RC} = Min.	—	85	—	80	—	70	—	60	mA	1, 2
Power Supply Current (Standby)	I _{CC2}	$\overline{\text{RAS}}$, $\overline{\text{CAS}}$ = V _{IH}	—	2	—	2	—	2	—	2	mA	1
		$\overline{\text{RAS}}$, $\overline{\text{CAS}}$ ≥ V _{CC} - 0.2 V	—	1	—	1	—	1	—	1	μA	1, 5
		—	200	—	200	—	200	—	200	—	200	μA
Average Power Supply Current ($\overline{\text{RAS}}$ -only Refresh)	I _{CC3}	$\overline{\text{RAS}}$ cycling, $\overline{\text{CAS}}$ = V _{IH} , t _{RC} = Min.	—	85	—	80	—	70	—	60	mA	1, 2
Power Supply Current (Standby)	I _{CC5}	$\overline{\text{RAS}}$ = V _{IH} , $\overline{\text{CAS}}$ = V _{IL} , DQ = enable	—	5	—	5	—	5	—	5	mA	1
Average Power Supply Current ($\overline{\text{CAS}}$ before $\overline{\text{RAS}}$ Refresh)	I _{CC6}	$\overline{\text{RAS}}$ cycling, $\overline{\text{CAS}}$ before $\overline{\text{RAS}}$	—	85	—	80	—	70	—	60	mA	1, 2
Average Power Supply Current (Fast Page Mode)	I _{CC7}	$\overline{\text{RAS}}$ = V _{IL} , $\overline{\text{CAS}}$ cycling, t _{PC} = Min.	—	80	—	75	—	65	—	55	mA	1, 3
Average Power Supply Current (Battery Backup)	I _{CC10}	t _{RC} = 125 μs, $\overline{\text{CAS}}$ before $\overline{\text{RAS}}$, t _{RAS} ≤ 1 μs	—	300	—	300	—	300	—	300	μA	1, 2, 4, 5

- Notes :
1. I_{CC} Max. is specified as I_{CC} for output open condition.
 2. The address can be changed once or less while $\overline{\text{RAS}}$ = V_{IL}.
 3. The address can be changed once or less while $\overline{\text{CAS}}$ = V_{IH}.
 4. V_{CC} - 0.2 V ≤ V_{IH} ≤ 6.5 V, -1.0 V ≤ V_{IL} ≤ 0.2 V.
 5. L-version.

AC Characteristics (1/2)

(V_{CC} = 5 V ±10%, T_a = 0°C to 70°C) Note 1, 2, 3, 4, 5

Parameter	Symbol	MSM514256 C/CL-45		MSM514256 C/CL-50		MSM514256 C/CL-60		MSM514256 C/CL-70		Unit	Note
		Min.	Max.	Min.	Max.	Min.	Max.	Min.	Max.		
		Random Read or Write Cycle Time	t _{RC}	90	—	100	—	120	—		
Read Modify Write Cycle Time	t _{RWC}	140	—	150	—	170	—	185	—	ns	
Fast Page Mode Cycle Time	t _{PC}	34	—	36	—	40	—	45	—	ns	
Fast Page Mode Read Modify Write Cycle Time	t _{PRWC}	75	—	77	—	90	—	95	—	ns	
Access Time from $\overline{\text{RAS}}$	t _{RAC}	—	45	—	50	—	60	—	70	ns	6, 7, 8
Access Time from $\overline{\text{CAS}}$	t _{CAC}	—	14	—	14	—	15	—	20	ns	6, 7
Access Time from Column Address	t _{AA}	—	24	—	26	—	30	—	35	ns	6, 8
Access Time from $\overline{\text{CAS}}$ Precharge	t _{CPA}	—	28	—	30	—	35	—	40	ns	6
Access Time from $\overline{\text{OE}}$	t _{OEA}	—	14	—	14	—	15	—	20	ns	6
Output Low Impedance Time from $\overline{\text{CAS}}$	t _{CLZ}	0	—	0	—	0	—	0	—	ns	6
$\overline{\text{CAS}}$ to Data Output Buffer Turn-off Delay Time	t _{OFF}	0	10	0	10	0	10	0	10	ns	9
$\overline{\text{OE}}$ to Data Output Buffer Turn-off Delay Time	t _{OEZ}	0	10	0	10	0	10	0	10	ns	9
Transition Time	t _T	3	50	3	50	3	50	3	50	ns	3
Refresh Period	t _{REF}	—	8	—	8	—	8	—	8	ms	
Refresh Period (L-version)	t _{REF}	—	64	—	64	—	64	—	64	ms	
$\overline{\text{RAS}}$ Precharge Time	t _{RP}	35	—	40	—	50	—	50	—	ns	
$\overline{\text{RAS}}$ Pulse Width	t _{RAS}	45	10,000	50	10,000	60	10,000	70	10,000	ns	
$\overline{\text{RAS}}$ Pulse Width (Fast Page Mode)	t _{RASP}	45	100,000	50	100,000	60	100,000	70	100,000	ns	
$\overline{\text{RAS}}$ Hold Time	t _{RSH}	14	—	14	—	15	—	20	—	ns	
$\overline{\text{RAS}}$ Hold Time referenced to $\overline{\text{OE}}$	t _{ROH}	10	—	10	—	10	—	10	—	ns	
$\overline{\text{CAS}}$ Precharge Time (Fast Page Mode)	t _{CP}	10	—	10	—	10	—	10	—	ns	
$\overline{\text{CAS}}$ Pulse Width	t _{CAS}	14	10,000	14	10,000	15	10,000	20	10,000	ns	
$\overline{\text{CAS}}$ Hold Time	t _{CSH}	45	—	50	—	60	—	70	—	ns	
$\overline{\text{CAS}}$ to $\overline{\text{RAS}}$ Precharge Time	t _{CRP}	5	—	5	—	5	—	5	—	ns	
$\overline{\text{RAS}}$ Hold Time from $\overline{\text{CAS}}$ Precharge	t _{RHCP}	28	—	30	—	35	—	40	—	ns	
$\overline{\text{RAS}}$ to $\overline{\text{CAS}}$ Delay Time	t _{RCD}	17	31	18	36	20	45	20	50	ns	7
$\overline{\text{RAS}}$ to Column Address Delay Time	t _{RAD}	12	21	13	24	15	30	15	35	ns	8
Row Address Set-up Time	t _{ASR}	0	—	0	—	0	—	0	—	ns	
Row Address Hold Time	t _{RAH}	7	—	8	—	10	—	10	—	ns	
Column Address Set-up Time	t _{ASC}	0	—	0	—	0	—	0	—	ns	
Column Address Hold Time	t _{CAH}	12	—	13	—	15	—	15	—	ns	
Column Address Hold Time from $\overline{\text{RAS}}$	t _{AR}	35	—	40	—	50	—	55	—	ns	
Column Address to $\overline{\text{RAS}}$ Lead Time	t _{RAL}	24	—	26	—	30	—	35	—	ns	

AC Characteristics (2/2)

(V_{CC} = 5 V ±10%, T_a = 0°C to 70°C) Note 1, 2, 3, 4, 5

Parameter	Symbol	MSM514256 C/CL-45		MSM514256 C/CL-50		MSM514256 C/CL-60		MSM514256 C/CL-70		Unit	Note
		Min.	Max.	Min.	Max.	Min.	Max.	Min.	Max.		
		Read Command Set-up Time	t _{RCS}	0	—	0	—	0	—		
Read Command Hold Time	t _{RCH}	0	—	0	—	0	—	0	—	ns	10
Read Command Hold Time referenced to $\overline{\text{RAS}}$	t _{RRH}	0	—	0	—	0	—	0	—	ns	10
Write Command Set-up Time	t _{WCS}	0	—	0	—	0	—	0	—	ns	11
Write Command Hold Time	t _{WCH}	10	—	10	—	10	—	15	—	ns	
Write Command Hold Time from $\overline{\text{RAS}}$	t _{WCR}	35	—	40	—	50	—	55	—	ns	
Write Command Pulse Width	t _{WP}	10	—	10	—	10	—	15	—	ns	
$\overline{\text{OE}}$ Command Hold Time	t _{OEH}	12	—	13	—	15	—	20	—	ns	
Write Command to $\overline{\text{RAS}}$ Lead Time	t _{RWL}	14	—	14	—	15	—	20	—	ns	
Write Command to $\overline{\text{CAS}}$ Lead Time	t _{CWL}	14	—	14	—	15	—	20	—	ns	
Data-in Set-up Time	t _{DS}	0	—	0	—	0	—	0	—	ns	12
Data-in Hold Time	t _{DH}	12	—	13	—	15	—	15	—	ns	12
Data-in Hold Time from $\overline{\text{RAS}}$	t _{DHR}	35	—	40	—	50	—	55	—	ns	
$\overline{\text{OE}}$ to Data-in Delay Time	t _{OED}	12	—	13	—	15	—	20	—	ns	
$\overline{\text{CAS}}$ to $\overline{\text{WE}}$ Delay Time	t _{CWD}	36	—	38	—	50	—	50	—	ns	11
Column Address to $\overline{\text{WE}}$ Delay Time	t _{AWD}	48	—	52	—	60	—	65	—	ns	11
$\overline{\text{RAS}}$ to $\overline{\text{WE}}$ Delay Time	t _{RWD}	70	—	75	—	90	—	100	—	ns	11
$\overline{\text{CAS}}$ Precharge $\overline{\text{WE}}$ Delay Time	t _{CPWD}	50	—	53	—	60	—	70	—	ns	11
$\overline{\text{CAS}}$ Active Delay Time from $\overline{\text{RAS}}$ Precharge	t _{RPC}	0	—	0	—	0	—	0	—	ns	
$\overline{\text{RAS}}$ to $\overline{\text{CAS}}$ Set-up Time ($\overline{\text{CAS}}$ before $\overline{\text{RAS}}$)	t _{CSR}	10	—	10	—	10	—	10	—	ns	
$\overline{\text{RAS}}$ to $\overline{\text{CAS}}$ Hold Time ($\overline{\text{CAS}}$ before $\overline{\text{RAS}}$)	t _{CHR}	25	—	25	—	30	—	30	—	ns	

- Notes:
1. A start-up delay of 100 μ s is required after power-up, followed by a minimum of eight initialization cycles ($\overline{\text{RAS}}$ -only refresh or $\overline{\text{CAS}}$ before $\overline{\text{RAS}}$ refresh) before proper device operation is achieved.
 2. The AC characteristics assume $t_T = 5$ ns.
 3. V_{IH} (Min.) and V_{IL} (Max.) are reference levels for measuring input timing signals. Transition times (t_T) are measured between V_{IH} and V_{IL} .
 4. $V_{IH} = 3.0$ V and $V_{IL} = 0.0$ V are reference levels for measuring input timing signals (speed ranks 45 and 50).
 5. $V_{IH} = 2.4$ V and $V_{IL} = 0.8$ V are reference levels for measuring input timing signals (speed ranks 60 and 70).
 6. This parameter is measured with a load circuit equivalent to 2 TTL loads and 100 pF.
 7. Operation within the t_{RCD} (Max.) limit ensures that t_{RAC} (Max.) can be met. t_{RCD} (Max.) is specified as a reference point only. If t_{RCD} is greater than the specified t_{RCD} (Max.) limit, then the access time is controlled by t_{CAC} .
 8. Operation within the t_{RAD} (Max.) limit ensures that t_{RAC} (Max.) can be met. t_{RAD} (Max.) is specified as a reference point only. If t_{RAD} is greater than the specified t_{RAD} (Max.) limit, then the access time is controlled by t_{AA} .
 9. t_{OFF} (Max.) and t_{OEZ} (Max.) define the time at which the output achieves the open circuit condition and are not referenced to output voltage levels.
 10. t_{RCH} or t_{RRH} must be satisfied for a read cycle.
 11. t_{WCS} , t_{CWD} , t_{RWD} , t_{AWD} and t_{CPWD} are not restrictive operating parameters. They are included in the data sheet as electrical characteristics only. If $t_{WCS} \geq t_{WCS}$ (Min.), then the cycle is an early write cycle and the data out will remain open circuit (high impedance) throughout the entire cycle. If $t_{CWD} \geq t_{CWD}$ (Min.) , $t_{RWD} \geq t_{RWD}$ (Min.), $t_{AWD} \geq t_{AWD}$ (Min.) and $t_{CPWD} \geq t_{CPWD}$ (Min.), then the cycle is a read modify write cycle and data out will contain data read from the selected cell; if neither of the above sets of conditions is satisfied, then the condition of the data out (at access time) is indeterminate.
 12. These parameters are referenced to the $\overline{\text{CAS}}$ leading edge in an early write cycle, and to the $\overline{\text{WE}}$ leading edge in an $\overline{\text{OE}}$ control write cycle, or a read modify write cycle.

TIMING WAVEFORM

Read Cycle

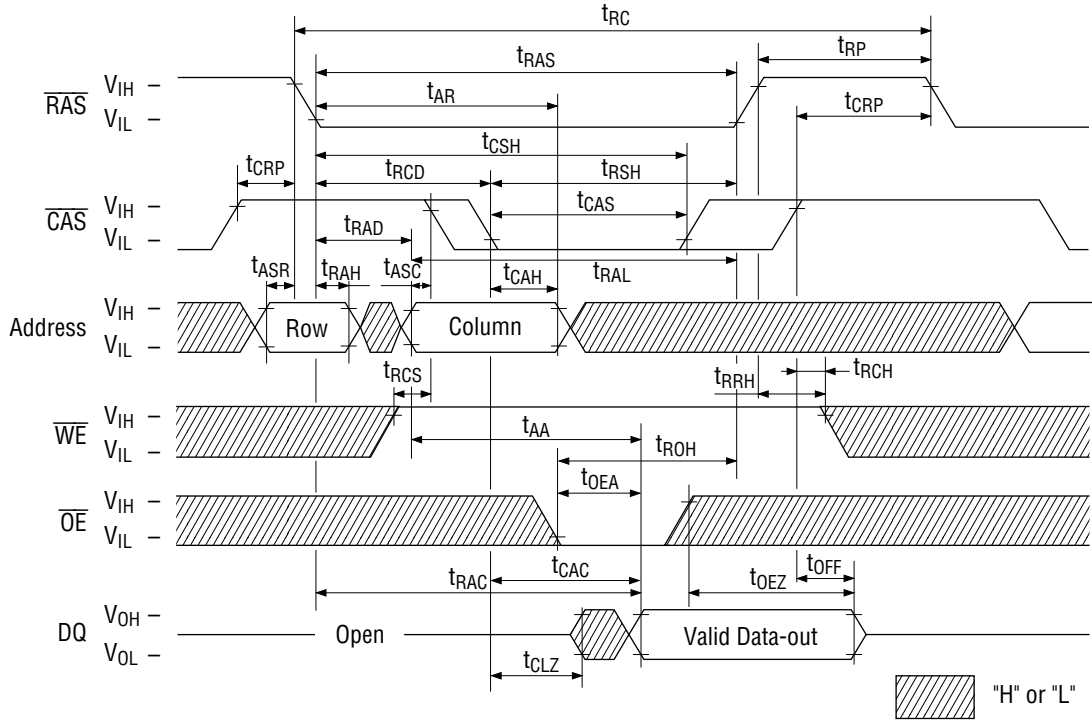

Write Cycle (Early Write)

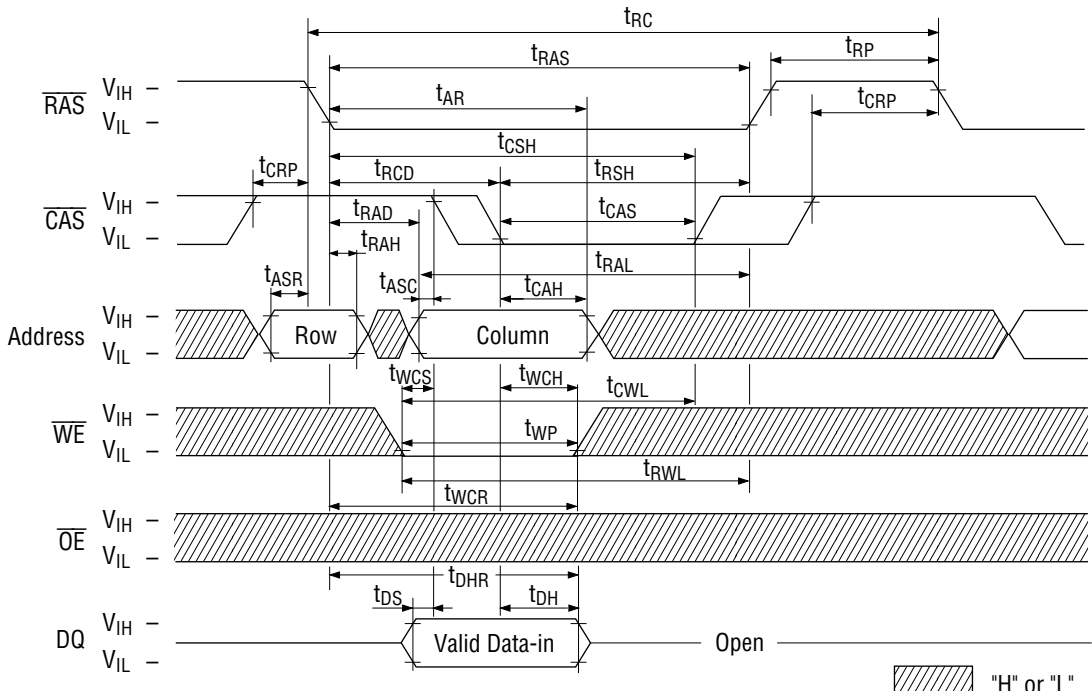

Read Modify Write Cycle

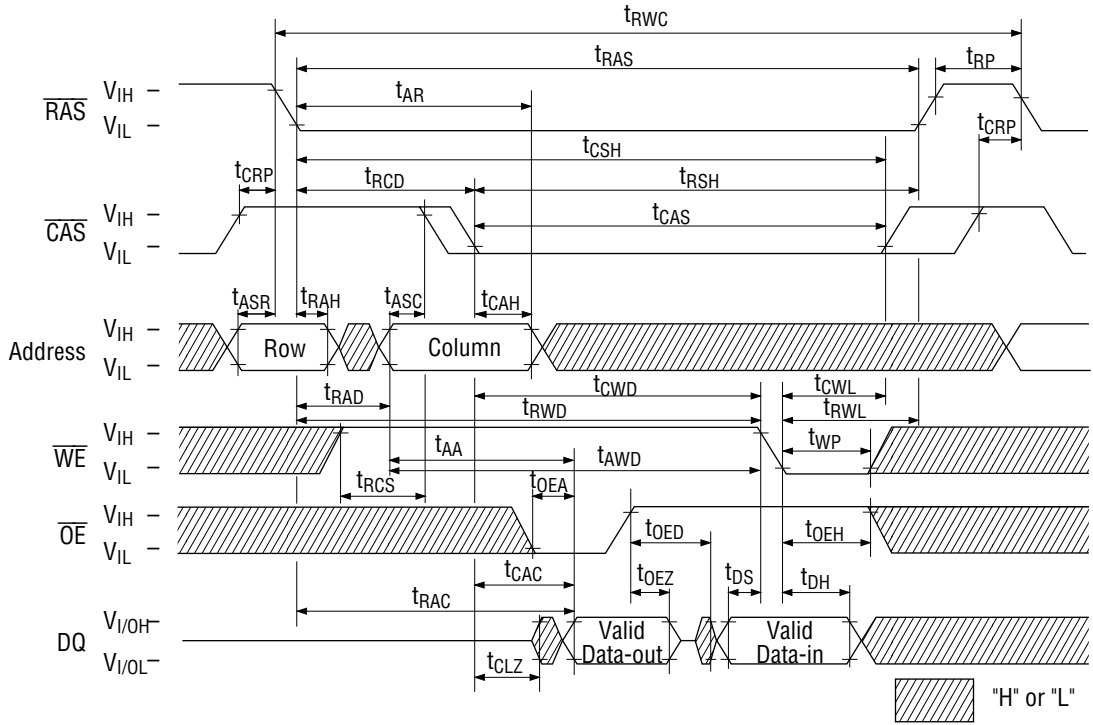

Fast Page Mode Read Cycle

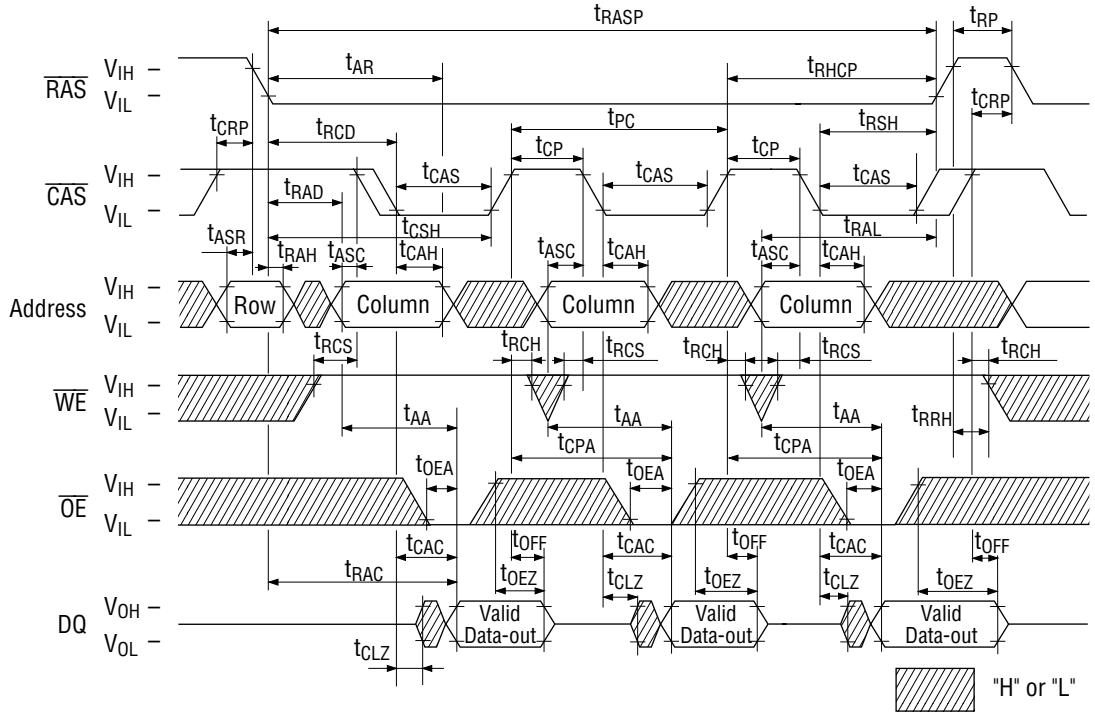

Fast Page Mode Write Cycle (Early Write)

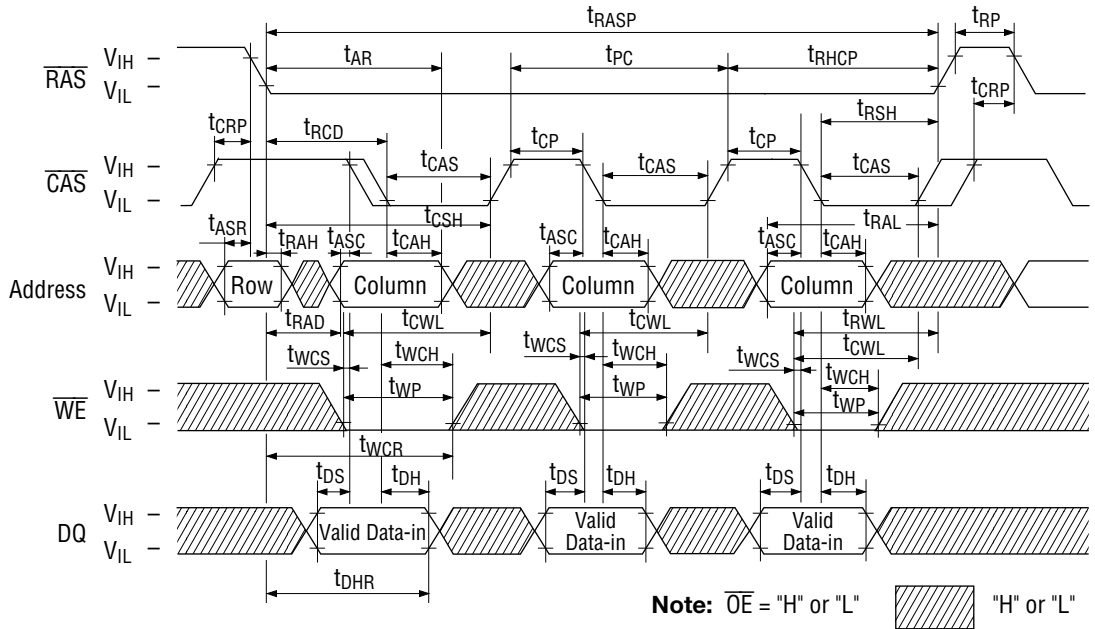

Fast Page Mode Read Modify Write Cycle

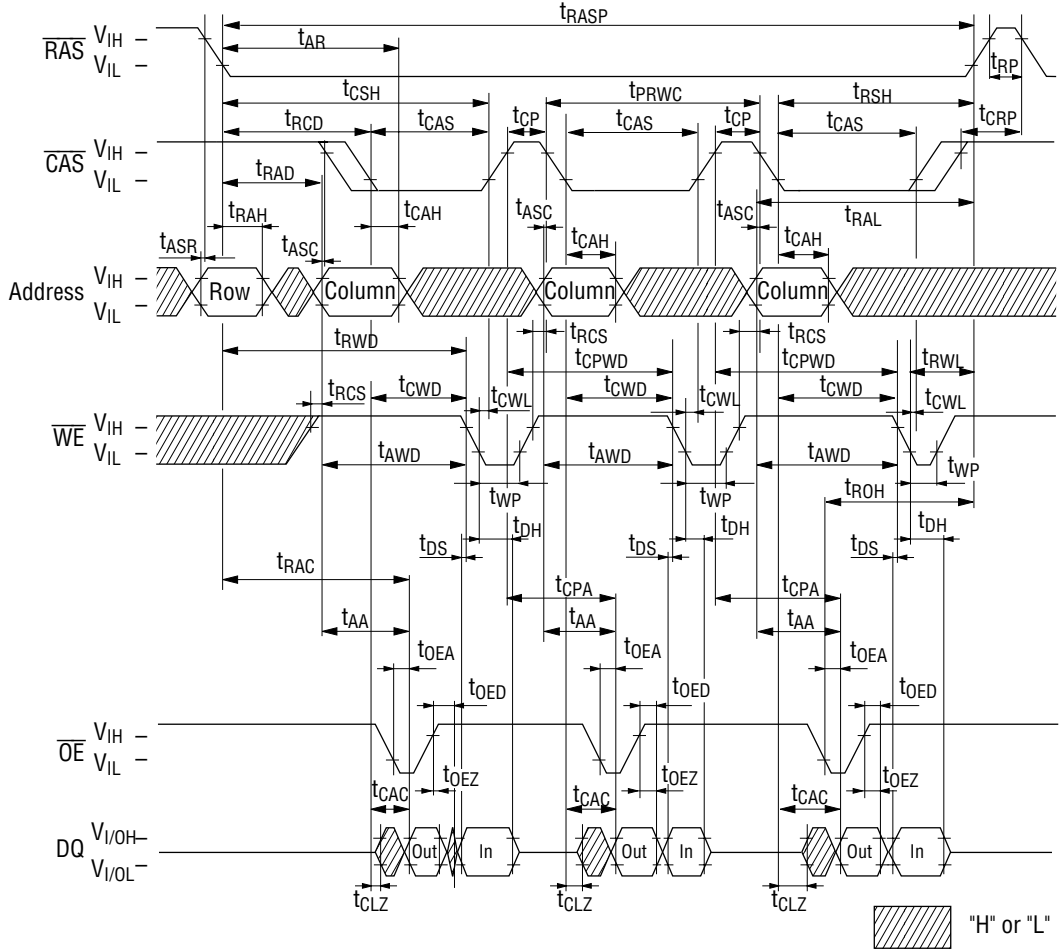

RAS-Only Refresh Cycle

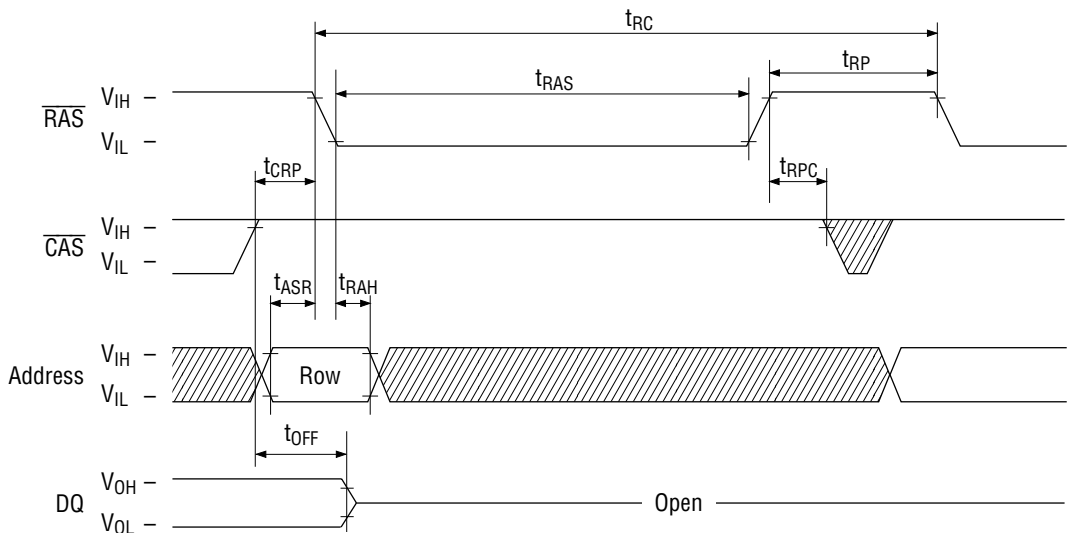

Note: \overline{WE} , \overline{OE} = "H" or "L"

"H" or "L"

CAS before RAS Refresh Cycle

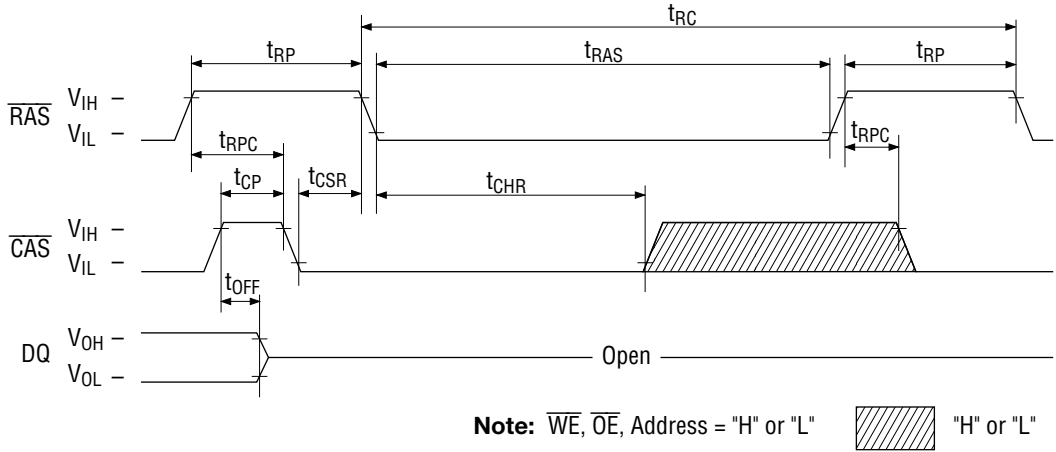

Hidden Refresh Read Cycle

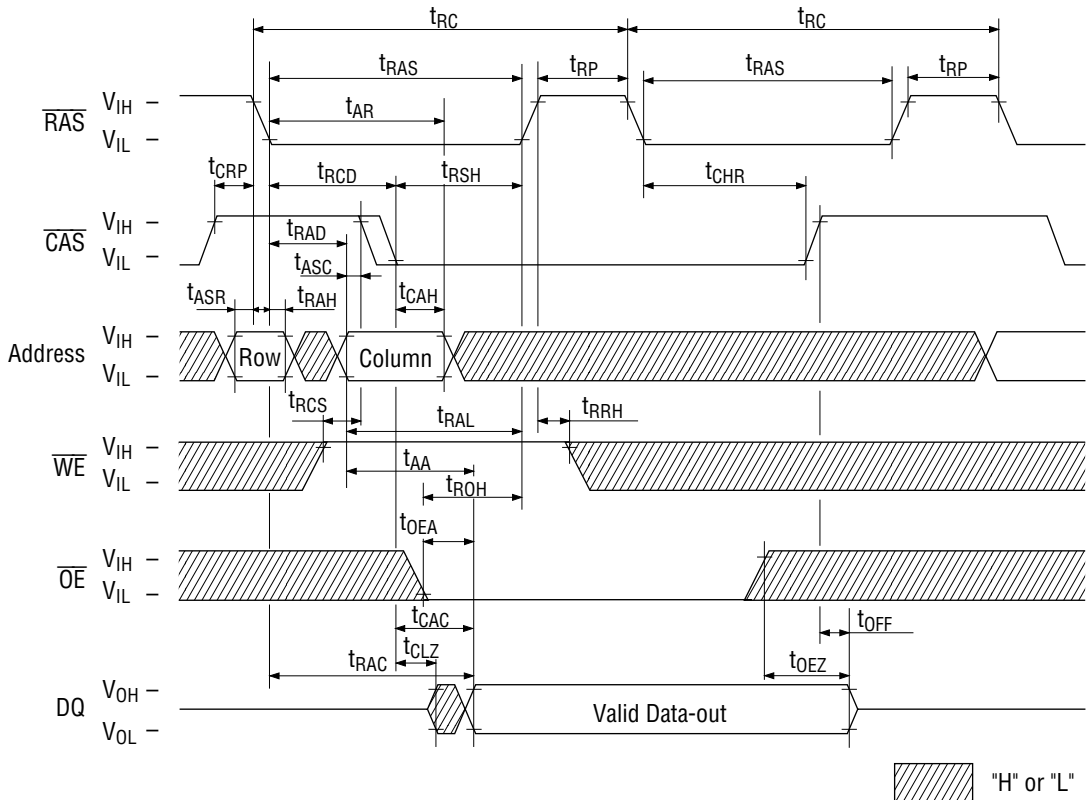

Hidden Refresh Write Cycle

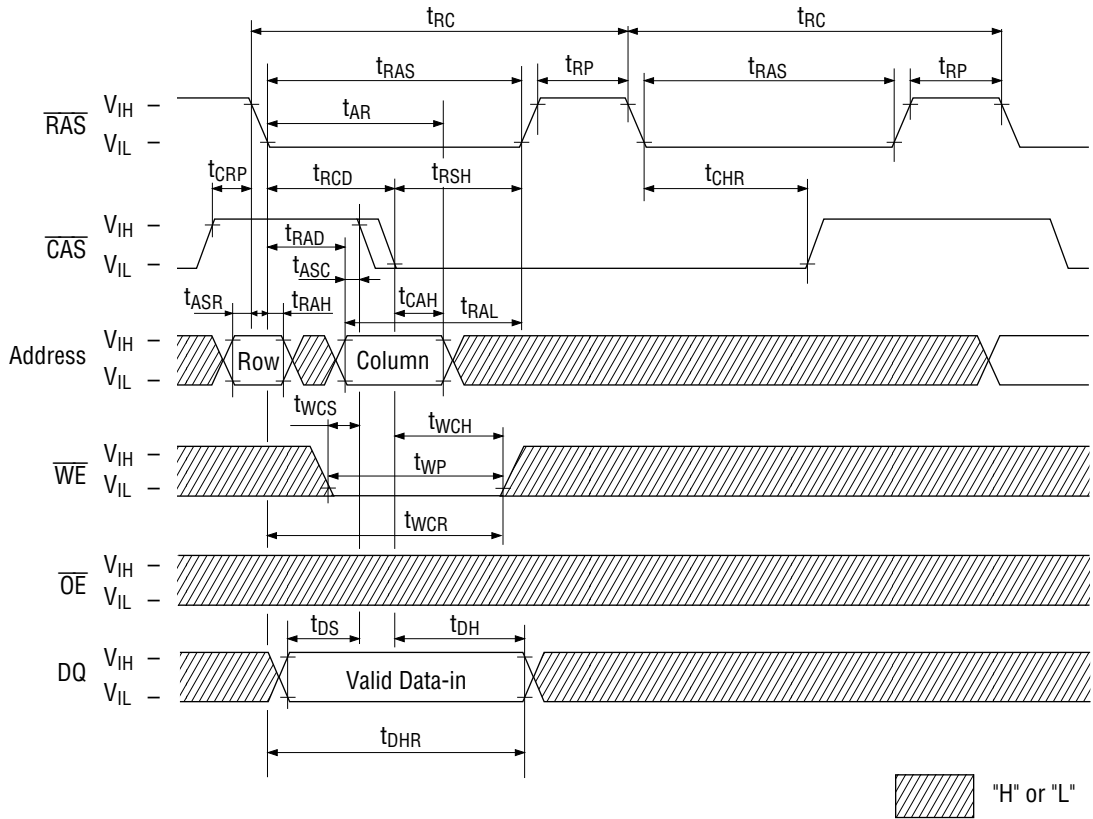

PACKAGE DIMENSIONS

(Unit : mm)

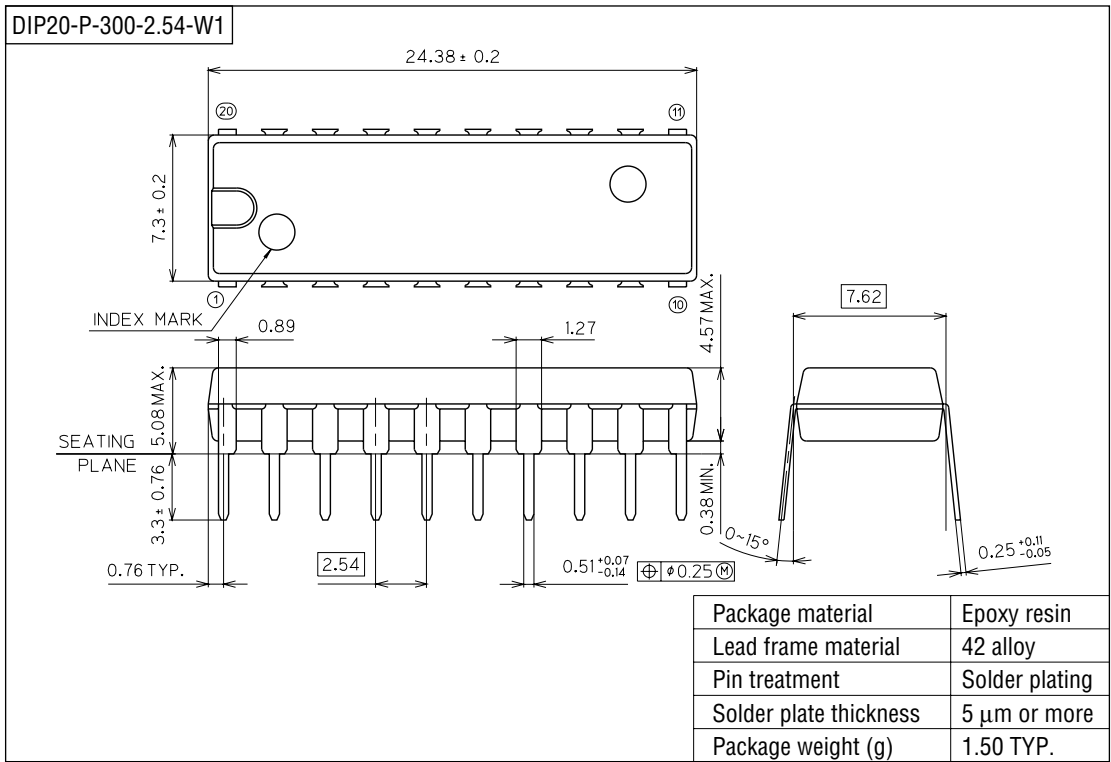

(Unit : mm)

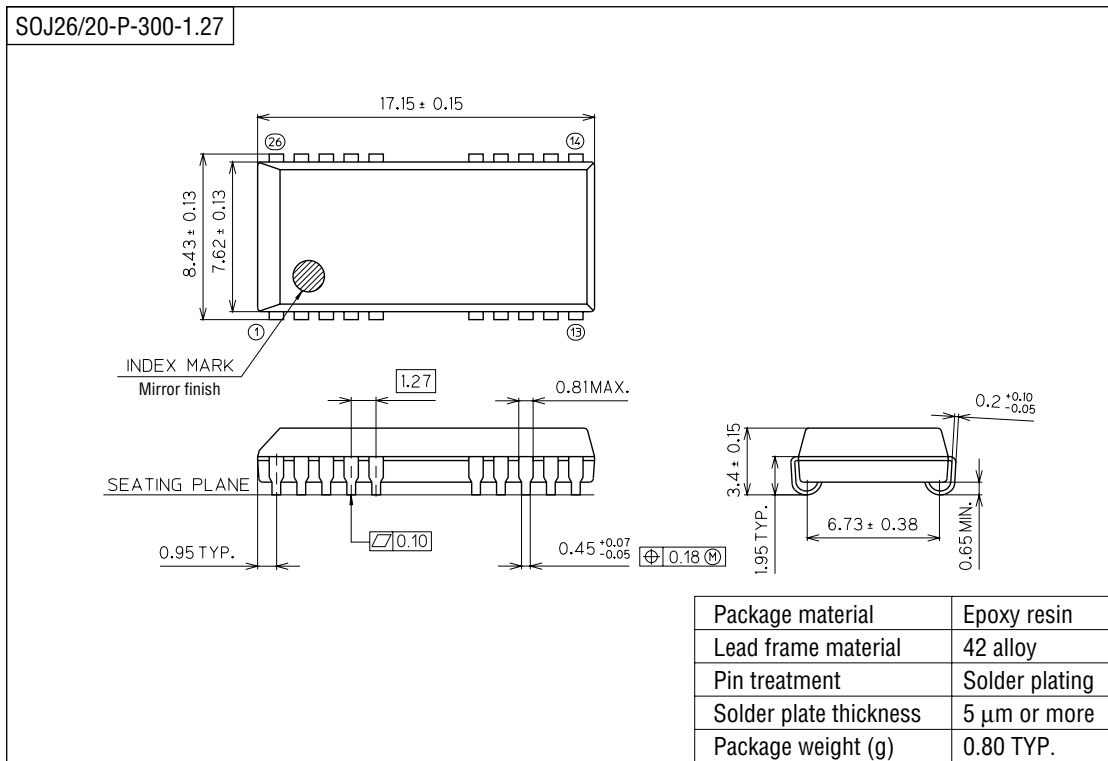

Notes for Mounting the Surface Mount Type Package

The SOP, QFP, TSOP, SOJ, QFJ (PLCC), SHP and BGA are surface mount type packages, which are very susceptible to heat in reflow mounting and humidity absorbed in storage. Therefore, before you perform reflow mounting, contact Oki's responsible sales person for the product name, package name, pin number, package code and desired mounting conditions (reflow method, temperature and times).

(Unit : mm)

